

# Low Profile - High performance, EMC/EMI IEC inlet filter

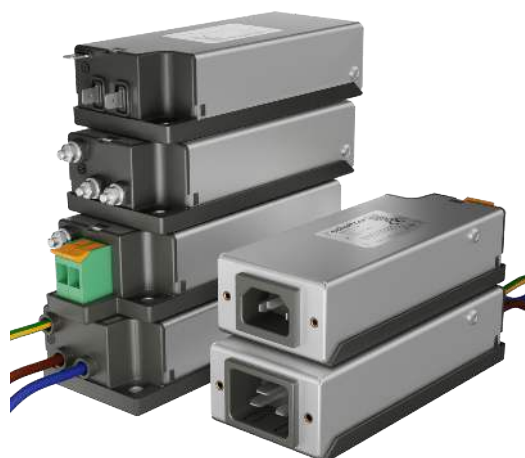

- Excellent IEC inlet for robotics, datacenters and other applications
- Terminals available on load side: Fast-on, wire leads, bolt, and clamps
- Voltage rating up to 250 VAC
- Fits within 1 height unit (HU) of a 19" rack application
- 40 °C operating temperature

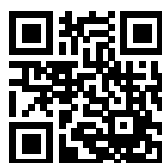

### Performance indicators

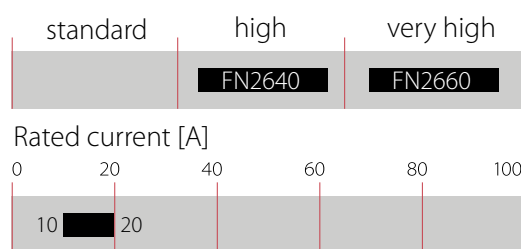

### Approvals & Compliances



Certifications FN2660 pending

### Features and Benefits

- FN2640 series fits perfectly within 1HU height for rack mount
- The filters are built to fit perfectly to datacenter and audio video equipment
- The shape allows convenient and space-saving installation
- Fulfills the requirements in IEC/EN 62040-1 - Uninterruptible power systems (UPS)
- Fulfills the requirements in IEC 62368-1 - Audio/Video, Information and Communication Technology Equipment
- Fulfills the requirements in IEC/EN 60335-1 - Household and similar appliances

### Typical Applications

- Robotics, collaborative robots, autonomous machines
- Audio and video equipment
- UPS - Uninterruptible power supplies

## Technical Specifications







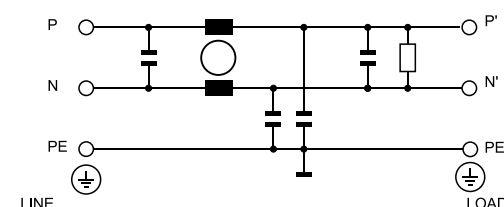

<b>Rated operating voltage</b>	250 VAC
<b>Operating frequency</b>	DC to 60 Hz
<b>Overvoltage category</b>	II acc. IEC 60664-1
<b>Overload capability</b>	1.5 x rated current for 1 minute once per hour
<b>Cooling</b>	Natural cooling AN
<b>Climatic category</b>	40/100/21 acc. IEC60068-1 FN2660: 40/085/21 acc. IEC60068-1 FN2660: 40/085/21 acc. IEC60068-1 FN2660: 40/085/21 acc. IEC60068-1
<b>Flammability according to</b>	Plastic Material: UL 94 V0 Laces for -07 version: UL 94 VW1
<b>Surge withstand</b>	2 kV Ph-Ph / 4 kV Ph-PE (Level 4)
<b>High potential test voltage</b>	P → N 1500 VDC for 2 sec* P/N → PE 2500 VDC for 2 sec*
<b>Altitude</b>	Derating above 2000 m
<b>Certified to</b>	UL 60939-3, IEC/EN 60939, GB/T 15287
<b>MTBF</b>	> 300,000 h
<b>Protection category</b>	IP00 / IP20 for -103 terminal
<b>Pollution degree</b>	2 acc. IEC 60664-1
<b>Vibration and shock</b>	3M12 acc. IEC 60721-3-3
<b>Temperature range (operation and storage)</b>	-40°C to +100°C (with derating >40°C) FN2660: -40°C to +85°C (with derating >40°C)
<b>Rated currents</b>	10 to 20 A @ 40°C

\* High potential test voltage: Repetition with max. 80% of specified values

### Typical electrical schematic



### Filter Selection Table

Filter	Rated current	Leakage current*	Power loss	Inductance**	Capacitance**			Resistance**	Connections				Weight max****	
	@ 40°C	@ 250 VAC/ 50 Hz	@ 25°C	L1	Cx1	Cx2	Cy1	R	line side	load side				
	[A]	(@ 120 VAC/ 60 Hz) [mA]	[W]	[mH]	[μF]	[μF]	[nF]	[kΩ]	C14 C20					[kg]
<b>Single-stage</b>														
<b>FN2640-10-yy-C11</b>	10	0.37 (0.21)	5.2	8.3	1	0.47	4.7	680		-05	-07	-08	-103	0.3
<b>FN2640-15-yy-C11</b>	15	0.37 (0.21)	6.8	4.0	1	0.47	4.7	680		-05	-07	-08	-103	0.3
<b>FN2640-16-yy-C11</b>	16	0.37 (0.21)	7.6	4.0	1	0.47	4.7	680		-05	-07	-08	-103	0.3
<b>FN2640-20-yy-C11</b>	20	0.37 (0.21)	7.2	2.4	1	0.47	4.7	680		-05	-07	-08	-103	0.3

\* Maximum leakage current under normal operating conditions. Note: if the neutral line is interrupted, worst case leakage current could reach twice this level.  
 \*\* Tolerances apply: Inductance: -30/+50%, Capacitance: ±20%, Resistance: ±10%.  
 \*\*\*Weight depending on choice of connectors.

**Product selector**

**FN2640-xx-yy-C11**

**yy – Load terminal type**  
 05: fast-on 6.3 x 0.8 mm  
 07: wire leads  
 08: M4 screw  
 103: push-in terminal

**xx – Rated current**  
 10-20: 10 A – 20 A

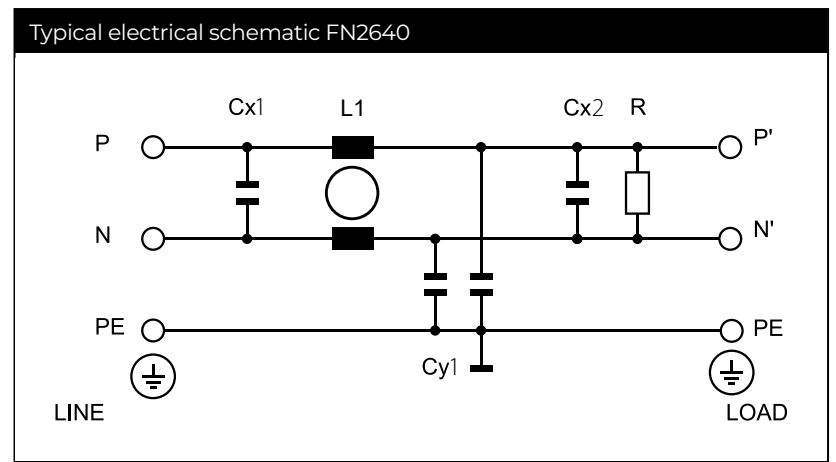

### Typical Filter Attenuation

Per CISPR 17: symmetrical 50 Ω/50 Ω -> Differential Mode (DM); asymmetrical 50 Ω/50 Ω -> Common Mode (CM)

FN2640 - Single-stage filter

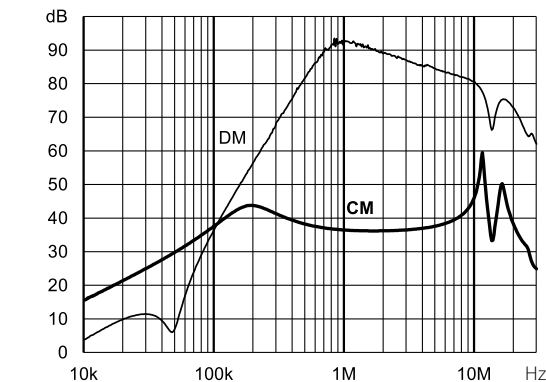

FN2640-10-yy-C11

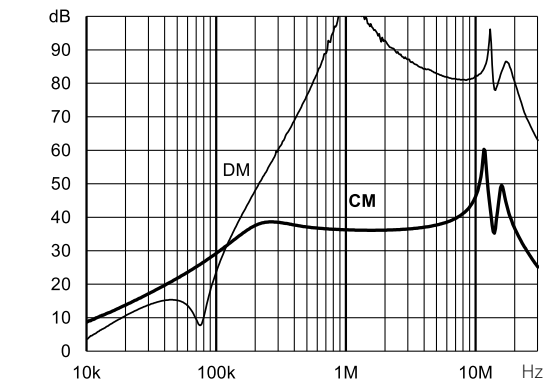

FN2640-15-yy-C11 & FN2640-16-yy-C11

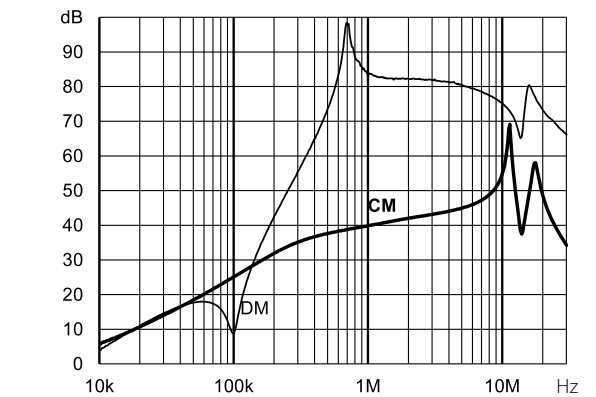

FN2640-20-yy-C11

### Dimensions FN2640 - Single-stage Filter

For dimensions [mm] without tolerances: ISO2768-cL/EN22768-cL applies

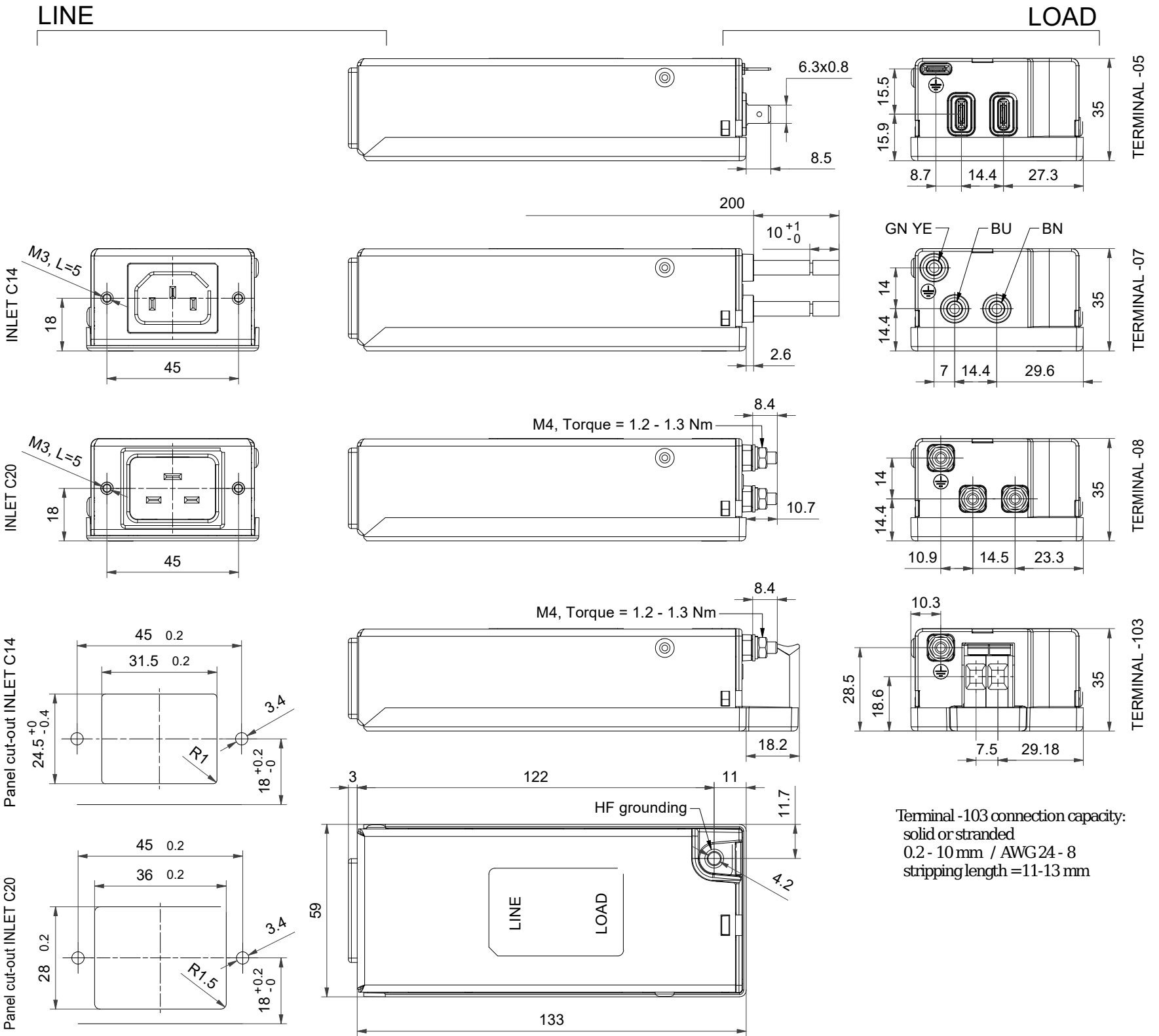

## Headquarters, Global Innovation and Development

### Switzerland

#### Schaffner Group

Industrie Nord  
Nordstrasse 11e  
4542  
Luterbach  
+41 32 681 66 26  
[info@schaffner.com](mailto:info@schaffner.com)

## Sales and Application Centers

### Finland

#### Schaffner Oy

Sauvonrinne 19 H  
8500  
Lohja  
+358 50 468 7284  
[finlandsales@schaffner.com](mailto:finlandsales@schaffner.com)

### France

#### Schaffner EMC S.A.S.

16-20 Rue Louis Rameau  
95875  
Bezons  
+33 1 34 34 30 60  
[francesales@schaffner.com](mailto:francesales@schaffner.com)

### Germany

#### Schaffner Deutschland GmbH

Schoemperlenstrasse 12B  
76185  
Karlsruhe  
+49 721 56910  
[germanysales@schaffner.com](mailto:germanysales@schaffner.com)

### India

#### Schaffner India Pvt. Ltd

Regus World Trade Centre  
WTC 22nd Floor Unit No 2238 Brigade  
Gateway Campus 26/1 Dr. Rajkumar Road  
Malleshwaram (W)  
560055  
Bangalore  
+91 8067935355  
[indiasales@schaffner.com](mailto:indiasales@schaffner.com)

### United Kingdom

#### Schaffner Ltd.

Suite 1 Oakmede Place  
Terrace Road  
RG42 4JF  
Binfield  
+44 118 9770070  
[uksales@schaffner.com](mailto:uksales@schaffner.com)

### United States

#### Schaffner EMC Inc.

52 Mayfield Avenue  
Edison, New Jersey  
+1 732 225 9533  
[usasales@schaffner.com](mailto:usasales@schaffner.com)

### Sweden

#### Schaffner EMC AB

Östermalmstrorg 1  
114 42  
Stockholm  
+46 8 5050 2425  
[swedensales@schaffner.com](mailto:swedensales@schaffner.com)

### Switzerland

#### Schaffner EMV AG

Industrie Nord  
Nordstrasse 11e  
4542  
Luterbach  
+41 32 681 66 26  
[switzerlandsales@schaffner.com](mailto:switzerlandsales@schaffner.com)

### Taiwan

#### Schaffner EMV Ltd.

U-Town  
20 Floor-2 No 97 Section 1 XinTai 5th Road  
XiZhi District  
22175  
New Taipei City  
+886 226975500  
[taiwansales@schaffner.com](mailto:taiwansales@schaffner.com)

### Italy

#### Schaffner EMC S.r.l.

Via Ticino, 30  
20900  
Monza (MB)  
+39 039 21 41 070  
[italysales@schaffner.com](mailto:italysales@schaffner.com)

### Japan

#### Schaffner EMC K.K.

ISM Sangenjaya  
7F 1-32-12 Kamiyuma Setagaya-ku  
154-0011  
Tokyo  
+81 3 5712 3650  
[japansales@schaffner.com](mailto:japansales@schaffner.com)

### Singapore

#### Schaffner EMC Pte Ltd.

Blk 3015A Ubi Road 1 #05-09 Kampong Ubi  
Industrial Estate  
408705  
Singapore  
+65 63773283  
[singaporesales@schaffner.com](mailto:singaporesales@schaffner.com)

To find your local partner within Schaffner's global network [schaffner.com](http://schaffner.com)

© 2023 Schaffner Group

The content of this document has been carefully checked and understood. However, neither Schaffner nor its subsidiaries assume any liability whatsoever for any errors or inaccuracies of this document and the consequences thereof. Published specifications are subject to change without notice. Product suitability for any area of application must ultimately be determined by the customer. In all cases, products must never be operated outside their published specifications. Schaffner does not guarantee the availability of all published products. This disclaimer shall be governed by substantive Swiss law and resulting disputes shall be settled by the courts at the place of business of Schaffner Holding AG. Latest publications and a complete disclaimer can be downloaded from the Schaffner website. All trademarks recognized.