

PART NUMBER	CIRCUIT SIZE	DIM. "A"	DIM. "B"
46100-0411	4	SEE SHEET 2	SEE SHEET 2
46100-0611	6	.331 (8.40)	.76 (19.2)
46100-1011	10	.661 (16.80)	1.09 (27.6)
46100-1411	14	.992 (25.20)	1.42 (36.0)
46100-1811	18	1.323 (33.60)	1.75 (44.4)
46100-2411	24	1.819 (46.20)	2.24 (57.0)

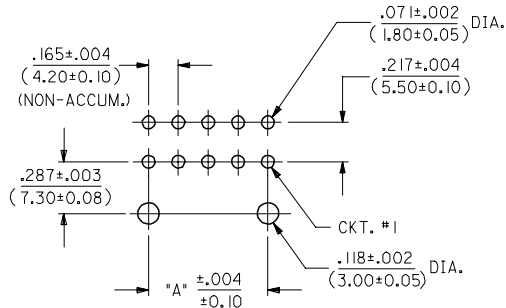
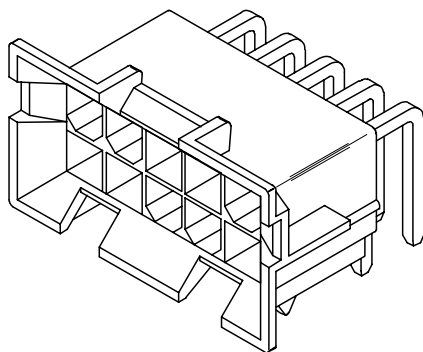
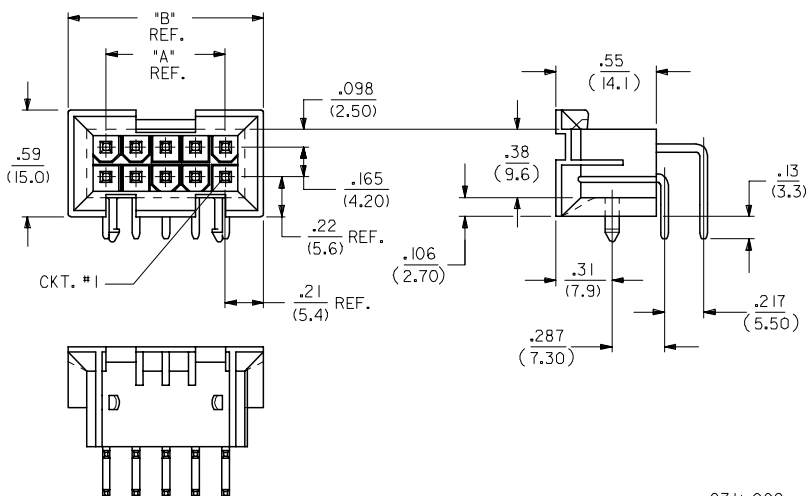
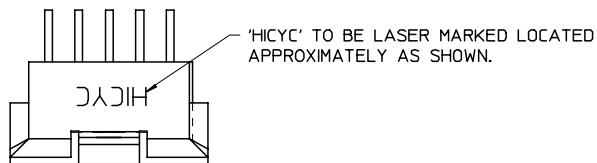

RECOMMENDED HOLE LAYOUT FOR .070/(1.78) MAX. THICK P.C. BOARD VIEWED FROM COMPONENT SIDE

**NOTES:**

- HOUSING MATERIAL: NYLON 6/6, U.L. 94V-0, COLOR: NATURAL
- TERMINAL MATERIAL: BRASS, ALLOY 260.
- PARTS MATE WITH MINI-FIT RECEPTACLES #44516, #46101 AND #42474.
- PART ALLOWS FOR UP TO .100/(2.54) MISALIGNMENT WITH MATING RECEPTACLE IN ANY DIRECTION. SEE MATING CONNECTOR DRAWINGS FOR SPECIFIC ALLOWANCES.
- TERMINAL PLATING: .000002/(.00005) MIN. GOLD OVER .000030/(.00076) MIN. PALLADIUM NICKEL IN THE CONTACT AREA. .000100/(.00254) MIN. TIN IN CRIMP AREA OVER .000050/(.00127) MIN. NICKEL OVERALL.
- PRODUCT SPECIFICATION AND PROCESSING PARAMETERS: SEE TBD
- CONNECTOR ASSEMBLIES ARE NOT TO BE MATED OR UNMATED WHILE CIRCUITS ARE LIVE.
- A MAXIMUM TOLERANCE OF .050/(1.27) ALLOWS FOR 2 POINTS OF ELECTRICAL CONTACT. A MAXIMUM TOLERANCE OF .020/(.51) ALLOWS FOR 4 POINTS OF CONTACT.
- DISCOLORATION IN THE BANDOLIER CARRIER AREA OF THE PIN IS INHERENT TO THE PLATING PROCESS AND IS DUE TO THE MASKING EFFECT OF THE CARRIER. THIS DISCOLORATION IS IN A NON-FUNCTIONAL AREA OF THE PIN AND WILL NOT AFFECT THE PERFORMANCE OF THE HEADER ASSEMBLY.

**FINISHED PART LEGEND**

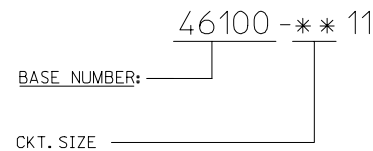

46100-\*\*\*11

REVISED NOTE 3 FEC NO: UCP2006-2876 DRAWN: STEWART 2006/06/06 CHKD: GREGORI 2006/06/06 APPR: JCOMERC I 2006/06/07	QUALITY SYMBOLS =0 =0	GENERAL TOLERANCES (UNLESS SPECIFIED)		DIMENSION STYLE IN/MM		SCALE	DESIGN UNITS METRIC	THIRD ANGLE PROJECTION	
		mm	INCH	DRAWN BY TGREGORI	DATE 2006/01/17	TITLE	MINI-FIT RIGHT ANGLE BMI HEADER ASSEMBLY (HIGH CYCLE SERIES)		
A2	DESCRIPTION	4 PLACES ± --- ± ---	3 PLACES ± --- ± .01	CHECKED BY JCOMERC I		MOLEX INCORPORATED			
		2 PLACES ± 0.25 ± .015	1 PLACE ± 0.38 ± ---	APPROVED BY JCOMERC I		DOCUMENT NO. SD-46100-001		SHEET NO. 1 OF 2	
DRAFT WHERE APPLICABLE MUST REMAIN WITHIN DIMENSIONS		ANGULAR ±1/2°		MATERIAL NO. SEE CHART		THIS DRAWING CONTAINS INFORMATION THAT IS PROPRIETARY TO MOLEX INCORPORATED AND SHOULD NOT BE USED WITHOUT WRITTEN PERMISSION			

13 12 11 10 9 8 7 6 5 4 3 2 1

J  
I  
H  
G  
F  
E  
D  
C  
B  
A

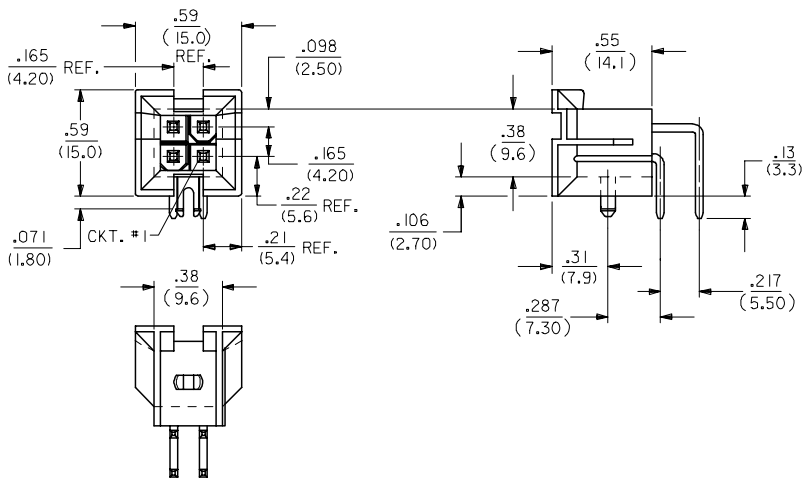

46100-0411

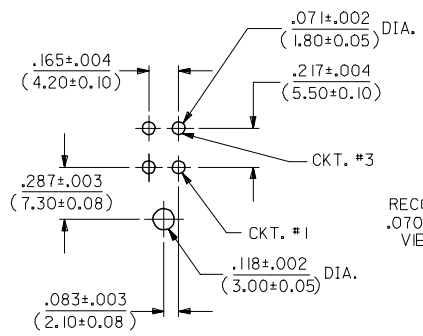
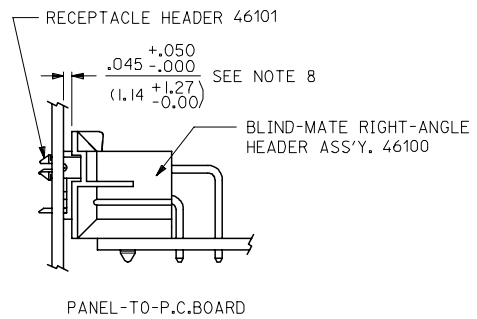

SEE SHEET ONE P.C. NO. UICP2006-2876 DRAWING STEWART 2006/06/06 CHK'D: T.GREGORI 2006/06/06 APPR: JCOMERC I 2006/06/07	QUALITY SYMBOLS ▽=0 ▽=0	GENERAL TOLERANCES (UNLESS SPECIFIED)		DIMENSION STYLE IN/MM		SCALE 1:1	DESIGN UNITS METRIC	THIRD ANGLE PROJECTION	
		4 PLACES ± --- ± ---	mm INCH	DRAWN BY T.GREGORI	DATE 2006/01/17	TITLE MINI-FIT RIGHT ANGLE BMI HEADER ASSEMBLY (HIGH CYCLE SERIES)			
		3 PLACES ± --- ± .01		CHECKED BY JCOMERC I	DATE	MOLEX INCORPORATED			
		2 PLACES ± 0.25 ± .015 1 PLACE ± 0.38 ± --- ANGULAR ±1/2°		APPROVED BY JCOMERC I	DATE	MATERIAL NO.	DOCUMENT NO. SD-46100-001	SHEET NO. 2 OF 2	
A2		DRAFT WHERE APPLICABLE MUST REMAIN WITHIN DIMENSIONS		SEE SHEET 1		THIS DRAWING CONTAINS INFORMATION THAT IS PROPRIETARY TO MOLEX INCORPORATED AND SHOULD NOT BE USED WITHOUT WRITTEN PERMISSION			

12 11 10 9 8 7 6 5 4 3 2 1