

Synchronous Boost Converter with LDO Controller

General Description

The RT9296 is a synchronous boost converter, which is based on a fixed frequency pulse-width-modulation (PWM) controller using a synchronous rectifier to obtain maximum efficiency. The converter provides a power supply solution for products powered by a variety of batteries such as single cell, dual cell alkaline, NiMH and NiCd battery. At light load currents, the converter enters the power save mode to maintain a high efficiency over a wide load current range.

The output voltage can be programmed by an external resistor divider, or be a fixed voltage. Moreover, the converter can be disabled to the minimize battery drain. During shutdown, the load is completely disconnected from the battery. The maximum peak current in the boost switch is limited to 2A for current limit.

For the RT9296, a low-EMI (anti-ringing) mode is implemented (by trim option) to reduce ringing of the inductor phase pin when the converter enters the discontinuous conduction mode. Moreover, a linear controller is built-in in the chip for linear regulator application.

Ordering Information

RT9296(-□□)□□

- Package Type
QW : WDFN-10L 3x3 (W-Type)
- Lead Plating System
G : Green (Halogen Free and Pb Free)
- Boost VOUT
Default : Adjustable
33 : 3.3V
50 : 5.0V

Note :

Richtek products are :

- ▶ RoHS compliant and compatible with the current requirements of IPC/JEDEC J-STD-020.
- ▶ Suitable for use in SnPb or Pb-free soldering processes.

Features

- True Load Disconnection During Shutdown
- Internal Synchronous Rectifier
- Up to 96% Efficiency
- Current Mode PWM Operation with Internal Compensation
- Low Start-Up Voltage
- Low Quiescent Current
- Internal Soft-Start Control
- Linear Controller
- Low EMI Converter (Anti-Ringing)
- Power Save Mode for Improved Efficiency at Light Load Current
- Over-Current Protection
- Short Circuit Protection
- Over Temperature Protection
- Over Voltage Protection
- Small 10-Lead WDFN Package
- RoHS Compliant and Halogen Free

Applications

- All One-Cell, Two-Cell and Three-Cell Alkaline, NiCd, NiMH and Single-Cell Li Batteries
- Hand-Held Devices
- WLED Flash Light

Pin Configurations

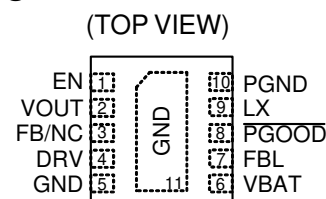

WDFN-10L 3x3

Marking Information

For marking information, contact our sales representative directly or through a Richtek distributor located in your area.

Typical Application Circuit

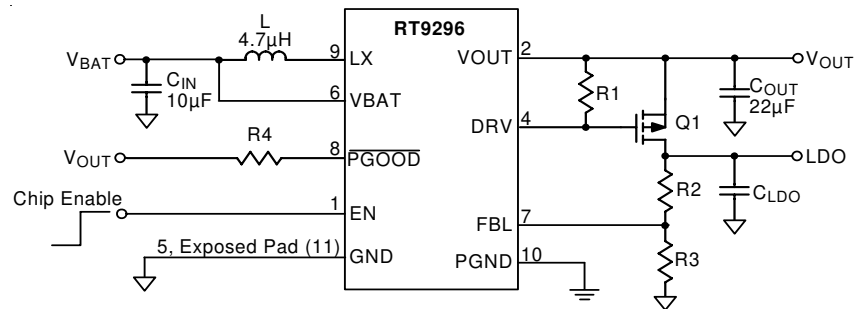

Figure 1. Fixed Output Voltage Boost Converter with Linear Regulator

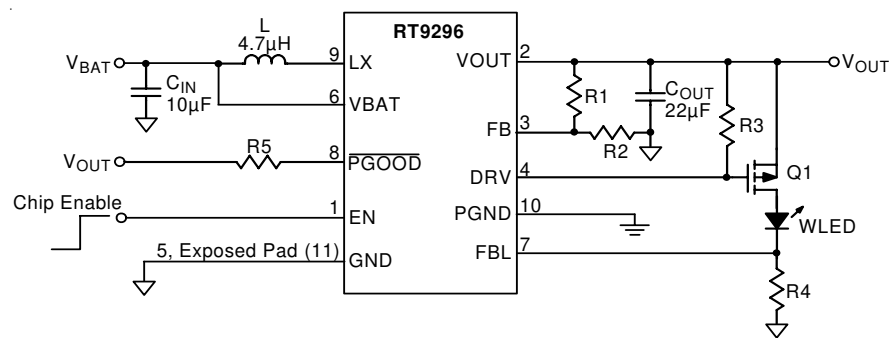

Figure 2. Adjustable Output Voltage Boost Converter with WLED Driver

Functional Pin Description

Pin No.	Pin Name	Pin Function
1	EN	Chip Enable (Active High).
2	VOUT	Boost Output.
3	FB / NC	Feedback Pin / No Internal Connection.
4	DRV	Driver of Linear Controller.
5	GND	Ground.
6	VBAT	Battery Supply Input.
7	FBL	Feedback Input Linear Controller.
8	PGOOD	Power Good Indicator.
9	LX	Switching Node. Connect this Pin to an inductor.
10	PGND	Power Ground.
11 (Exposed Pad)	GND	Ground. The exposed pad must be soldered to a large PCB and connected to GND for maximum power dissipation.

Function Block Diagram

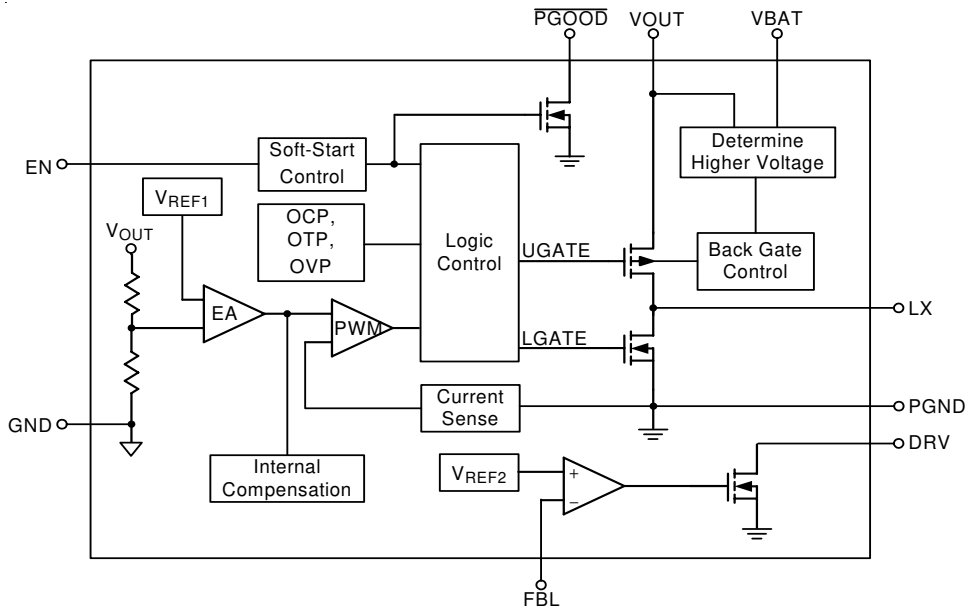

Figure 3. Fixed Voltage Regulator

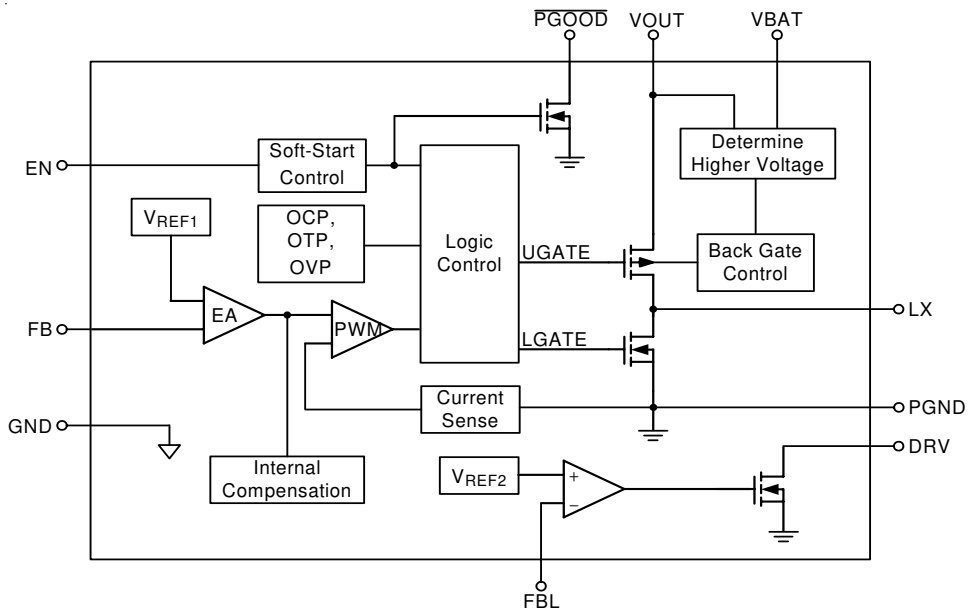

Figure 4. Adjustable Voltage Regulator

Absolute Maximum Ratings (Note 1)

- Supply Input Voltage, V_{BAT} ----- -0.3V to 6V
- Boost Output Voltage, V_{OUT} ----- -0.3V to 6.5V
- Switch Output Voltage, LX ----- -0.3V to 6.5V
- Digital Input Voltage, EN, FBL ----- -0.3V to 6V
- Digital Output Voltage, DRV, \overline{PGOOD} ----- -0.3V to 6V
- Others Pin ----- -0.3V to 6V
- Power Dissipation, $P_D @ T_A = 25^\circ\text{C}$
 WDFN-10L 3x3 ----- 1.429W
- Package Thermal Resistance (Note 2)
 WDFN-10L 3x3, θ_{JA} ----- 70°C/W
 WDFN-10L 3x3, θ_{JC} ----- 7.8°C/W
- Junction Temperature Range ----- 150°C
- Lead Temperature (Soldering, 10 sec.) ----- 260°C
- Storage Temperature Range ----- -65°C to 150°C
- ESD Susceptibility (Note 3)
 HBM (Human Body Mode) ----- 2kV
 MM (Machine Mode) ----- 200V

Recommended Operating Conditions (Note 4)

- Supply Input Voltage Range, V_{BAT} ----- 1.2V to 5V
- Junction Temperature Range ----- -40°C to 125°C
- Ambient Temperature Range ----- -40°C to 85°C

Electrical Characteristics

($V_{BAT} \geq 2.5\text{V}$ or $V_{BAT} = V_{OUT} + 0.7\text{V}$, $V_{EN} = V_{BAT}$, $C_{IN} = 10\mu\text{F}$, $C_{OUT} = 22\mu\text{F}$, $T_A = 25^\circ\text{C}$, unless otherwise specified)

Parameter	Symbol	Test Conditions	Min	Typ	Max	Unit
DC/DC Stage						
Start-Up Input Voltage	V_{BAT}	$I_{Load} = 1\text{mA}$	--	1.2	--	V
Input Voltage Range After Start-Up	V_{BAT}		0.8	--	5	V
Output Voltage Range	V_{OUT}		--	--	5	V
EN Threshold Voltage	V_{EN}	Rising Threshold Voltage	0.49	0.5	0.51	V
		Hysteresis Voltage	--	0.1	--	
Feedback Reference Voltage	V_{FB}	For Adjustable Output Voltage	0.49	0.5	0.51	V
Output Voltage Accuracy	ΔV_{OUT}	For Fixed Output Voltage	-3	--	+3	%
Switching Frequency	f_{SW}		--	1.2	--	MHz
Maximum Duty Cycle	D_{MAX}		--	90	--	%
Non-Switching Quiescent Current	$I_{Q,NS}$	No Switching	--	100	--	μA
Shutdown Current	I_{SHDN}	$V_{EN} = 0$, $V_{BAT} = 1.2\text{V}$	--	10	--	μA

To be continued

Parameter	Symbol	Test Conditions	Min	Typ	Max	Unit
Protection						
Over-Temperature Protection	T _{OTP}		--	170	--	°C
Over-Temperature Hysteresis	T _{OTP_Hys}		--	40	--	°C
Over-Current Protection	I _{OCP}	V _{OUT} = 3.3V	1.6	2	2.4	A
Over-Voltage Protection	V _{OVP}		5.5	--	6.5	V
Power MOSFET						
N-MOSFET ON-Resistance	R _{DS(ON)_N}	V _{OUT} = 3.3V	--	260	--	mΩ
P-MOSFET ON-Resistance	R _{DS(ON)_P}	V _{OUT} = 3.3V	--	290	--	mΩ
Linear Controller						
FBL Reference Voltage	V _{FBL}		0.19	0.2	0.21	V
Output Impedance of Linear Controller	R _{ON_LBO}	V _{LBI} = 0V	--	2	--	kΩ

Note 1. Stresses listed as the above "Absolute Maximum Ratings" may cause permanent damage to the device. These are for stress ratings. Functional operation of the device at these or any other conditions beyond those indicated in the operational sections of the specifications is not implied. Exposure to absolute maximum rating conditions for extended periods may remain possibility to affect device reliability.

Note 2. θ_{JA} is measured in the natural convection at T_A = 25°C on a high effective four layers thermal conductivity test board of JEDEC 51-7 thermal measurement standard. The case point of θ_{JC} is on the expose pad for the WDFN package.

Note 3. Devices are ESD sensitive. Handling precaution is recommended.

Note 4. The device is not guaranteed to function outside its operating conditions.

Typical Operating Characteristics

Efficiency vs. Load Current

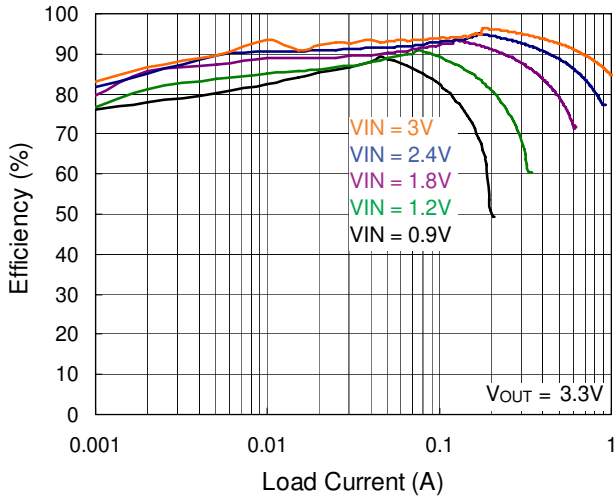

Efficiency vs. Load Current

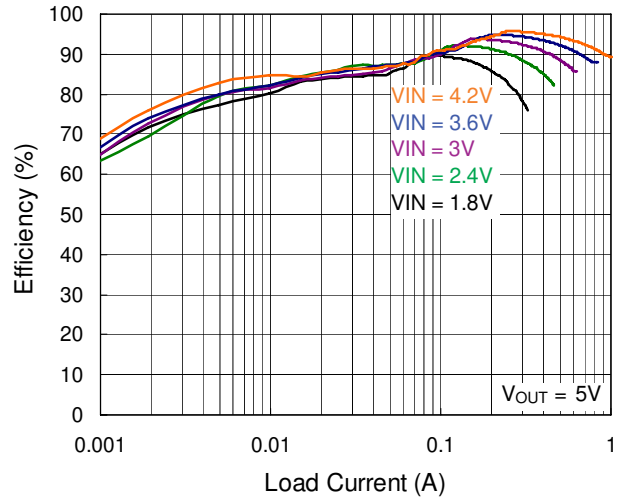

Efficiency vs. Input Voltage

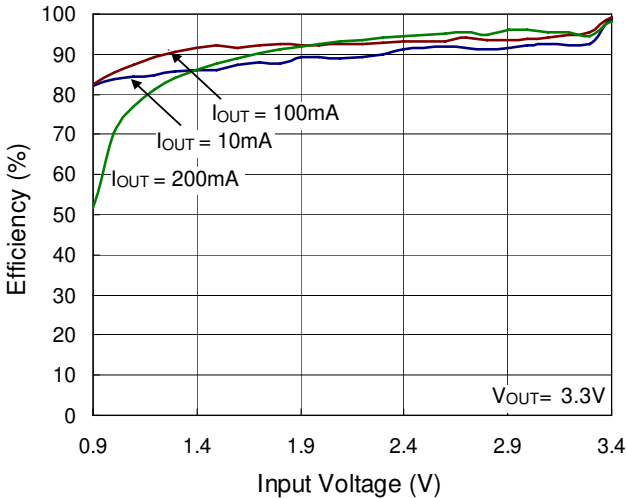

Efficiency vs. Input Voltage

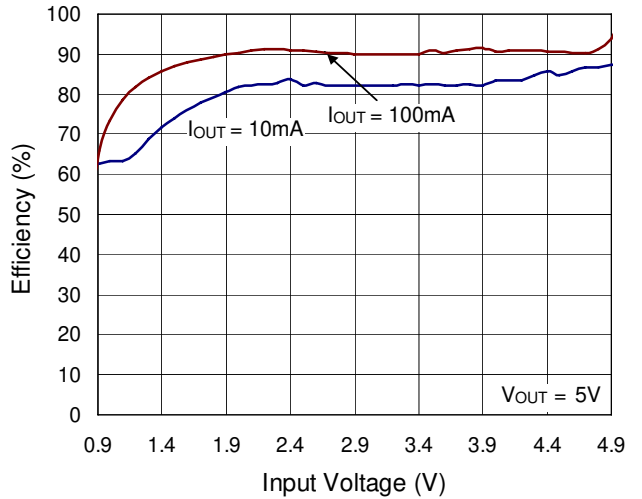

Output Voltage vs. Load Current

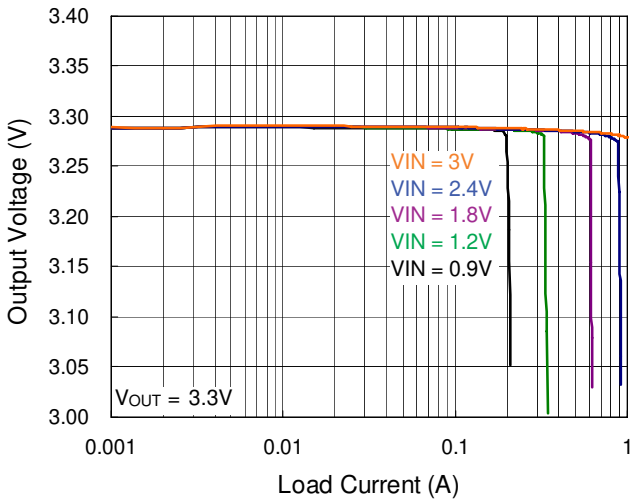

Output Voltage vs. Load Current

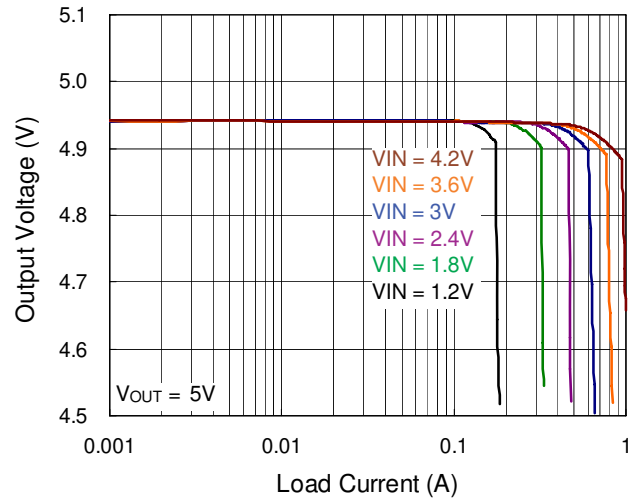

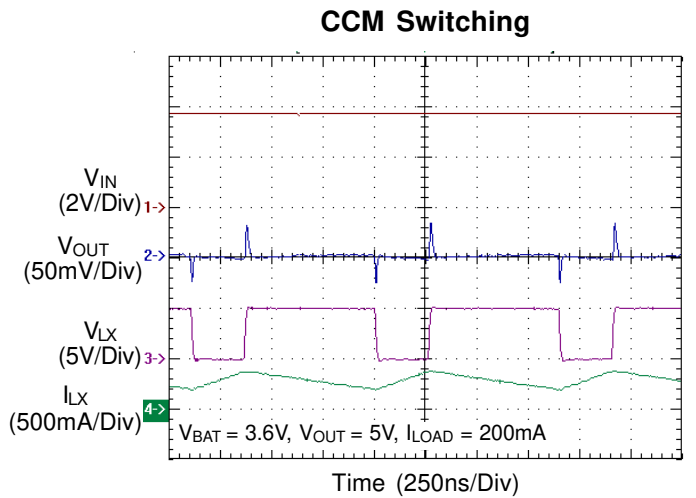
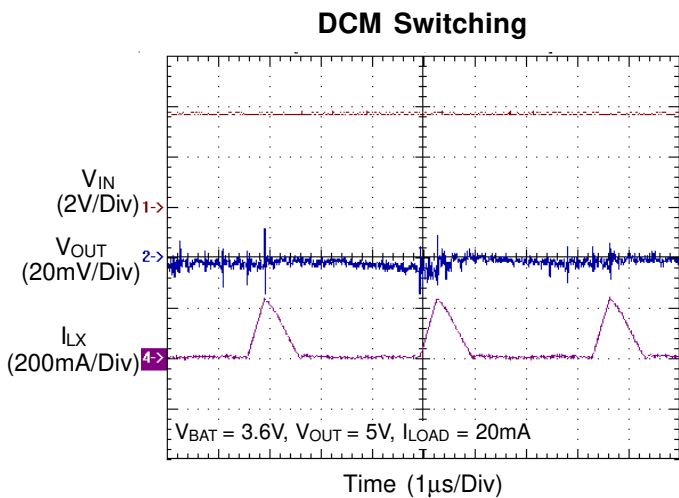
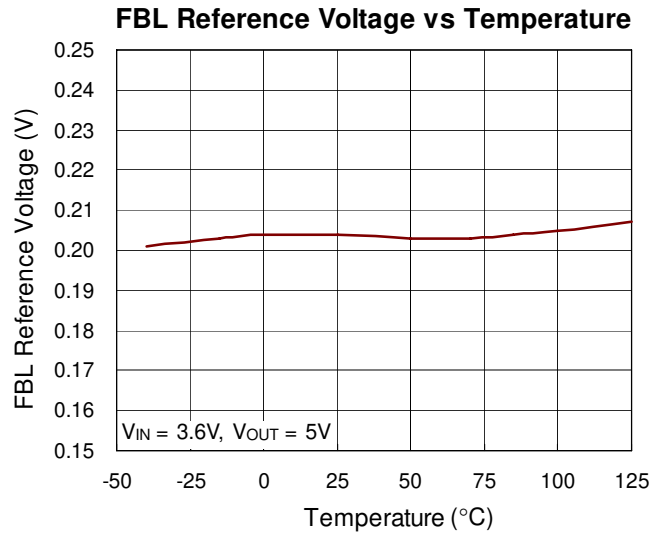
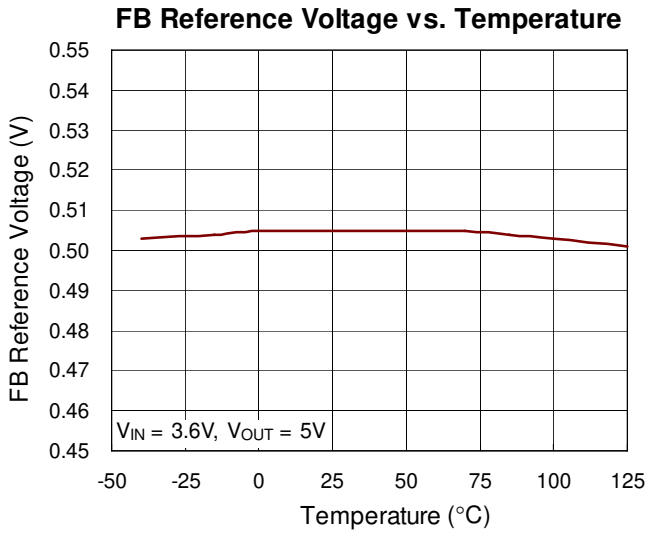
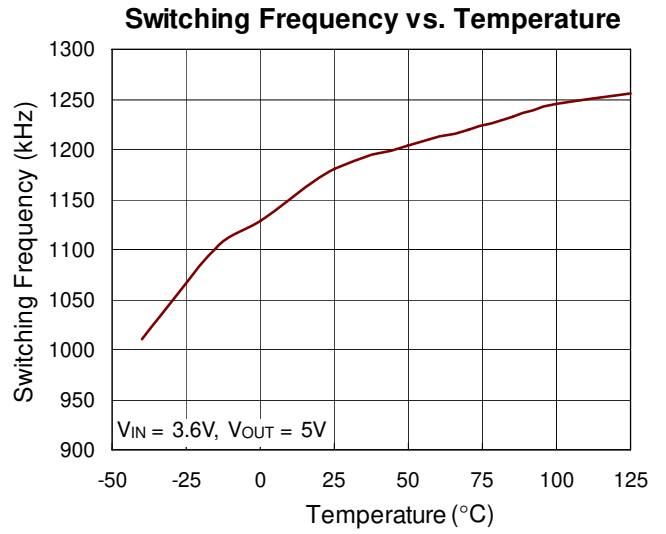
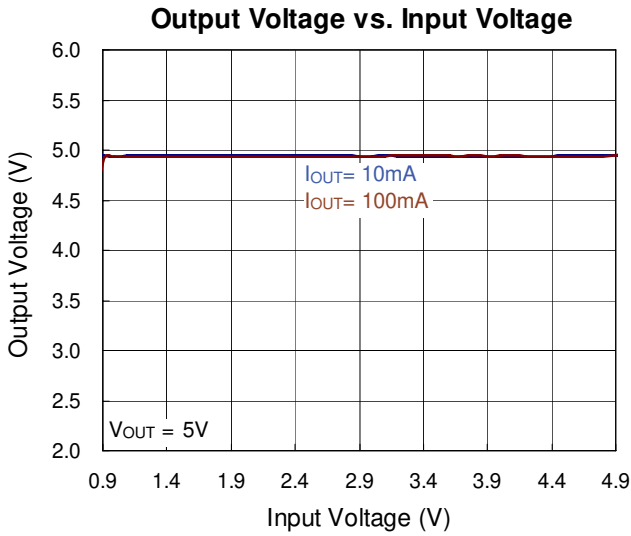

Load Transient Response

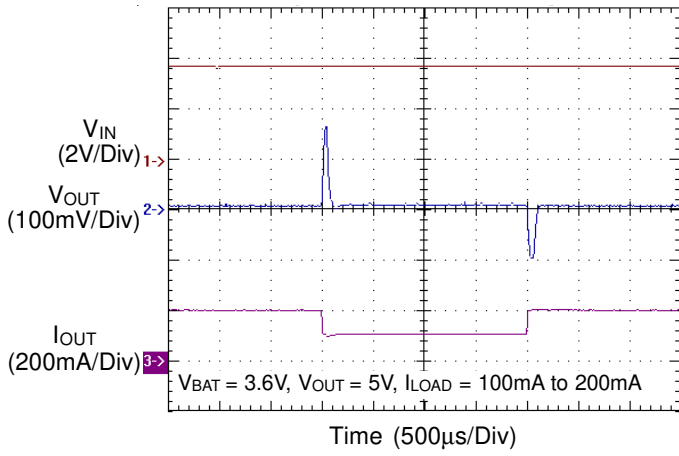

Line Transient Response

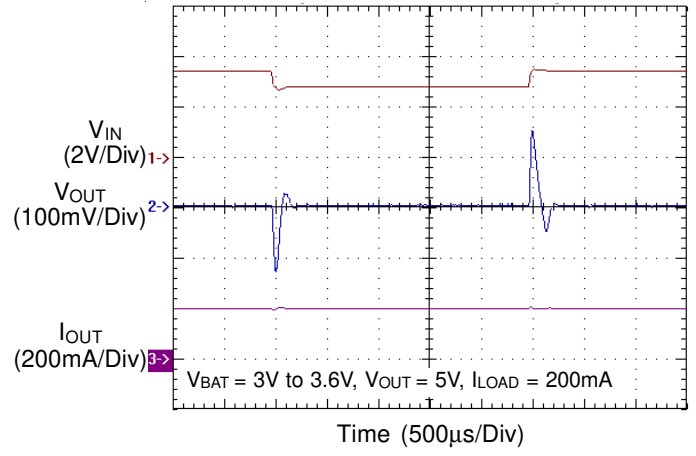

Application Information

The RT9296 integrates a high-efficiency synchronous step-up DC-DC converter and a linear regulator controller. To fully utilize its advantages, peripheral components should be appropriately selected. The following information provides detailed description of application.

Inductor Selection

For a better efficiency in high switching frequency converter, the inductor selection has to use a proper core material such as ferrite core to reduce the core loss and choose low ESR wire to reduce copper loss. The most important point is to prevent the core saturation when handling the maximum peak current. Using a shielded inductor can minimize radiated noise in sensitive applications. The maximum peak inductor current is the maximum input current plus the half of inductor ripple current. The calculated peak current has to be smaller than the current limitation in the electrical characteristics. A typical setting of the inductor ripple current is 20% to 40% of the maximum input current. If the selection is 40%

$$I_{PK} = I_{IN(MAX)} + \frac{1}{2} I_{RIPPLE} = 1.2 \times I_{IN(MAX)}$$

$$= 1.2 \times \left[\frac{I_{OUT(MAX)} \times V_{OUT}}{\eta \times V_{IN(MIN)}} \right]$$

The minimum inductance value is derived from the following equation :

$$L = \frac{\eta \times I_{IN(MIN)}^2 \times [V_{OUT} - V_{IN(MIN)}]}{0.4 \times I_{OUT(MAX)} \times V_{OUT}^2 \times f_{SW}}$$

Depending on the application, the recommended inductor value is between 2.2μH and 10μH.

Input Capacitor Selection

For better input bypassing, low-ESR ceramic capacitors are recommended for performance. A 10μF input capacitor is sufficient for most applications. For a lower output power requirement application, this value can be decreased

Output Capacitor Selection

For lower output voltage ripple, low-ESR ceramic capacitors are recommended. The tantalum capacitors can be used as well, but the ESR is bigger than ceramic capacitor. The output voltage ripple consists of two components: one is the pulsating output ripple current

flows through the ESR, and the other is the capacitive ripple caused by charging and discharging.

$$V_{RIPPLE} = V_{RIPPLE(ESR)} + V_{RIPPLE(C)}$$

$$\cong I_{PEAK} \times R_{ESR} + \frac{I_{PEAK}}{C_{OUT}} \left[\frac{V_{OUT} - V_{IN}}{V_{OUT} \times f_{SW}} \right]$$

Output Voltage Setting

Referring to application circuit (Figure 2), the output voltage of the switching regulator (V_{OUT}) can be set with below equation :

$$V_{OUT} = \left(1 + \frac{R1}{R2} \right) \times V_{FB}$$

where $V_{FB} = 0.5V$ (typ.)

Linear Regulator

The RT9296 integrates a linear controller with an open-drain output. An external P-MOSFET and external feedback resistors are required for this application. The feedback voltage is set at 0.2V typically.

For linear regulator application, the output voltage can be set by an external voltage resistive divider. For WLED driver application, the LED current can be set by an external feedback resistor.

Thermal Considerations

For continuous operation, do not exceed absolute maximum operation junction temperature. The maximum power dissipation depends on the thermal resistance of IC package, PCB layout, the rate of surroundings airflow and temperature difference between junction to ambient. The maximum power dissipation can be calculated by following formula :

$$P_{D(MAX)} = (T_{J(MAX)} - T_A) / \theta_{JA}$$

Where $T_{J(MAX)}$ is the maximum operation junction temperature, T_A is the ambient temperature and the θ_{JA} is the junction to ambient thermal resistance.

For recommended operating conditions specification of RT9296, the maximum junction temperature is 125°C. The junction to ambient thermal resistance θ_{JA} is layout dependent. For WDFN-10L 3x3 packages, the thermal resistance θ_{JA} is 70°C/W on the standard JEDEC 51-7 four layers thermal test board. The maximum power dissipation at $T_A = 25^\circ C$ can be calculated by following

formula :

$$P_{D(MAX)} = (125^{\circ}\text{C} - 25^{\circ}\text{C}) / (70^{\circ}\text{C}/\text{W}) = 1.429\text{W for WDFN-10L 3x3 packages}$$

The maximum power dissipation depends on operating ambient temperature for fixed $T_{J(MAX)}$ and thermal resistance θ_{JA} . For RT9296 packages, the Figure 5 of derating curves allows the designer to see the effect of rising ambient temperature on the maximum power allowed.

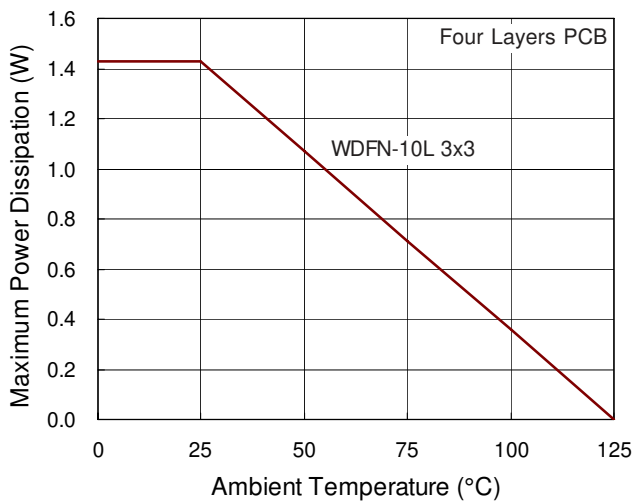

Figure 5. Derating Curves for RT9296 Packages

Layout Consideration

For Best performance of RT9296, the following layout guidelines must be strictly followed.

- ▶ Input and Output capacitors should be placed close to the IC and connected to ground plane to reduce noise coupling.
- ▶ The GND and Exposed Pad should be connected to a strong ground plane for heat sinking and noise protection.
- ▶ Keep the main current traces as possible as short and wide.
- ▶ Place the feedback components as close as possible to the IC and keep away from the noisy devices.

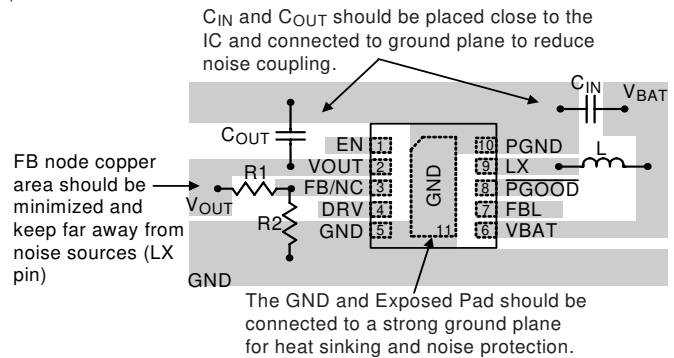
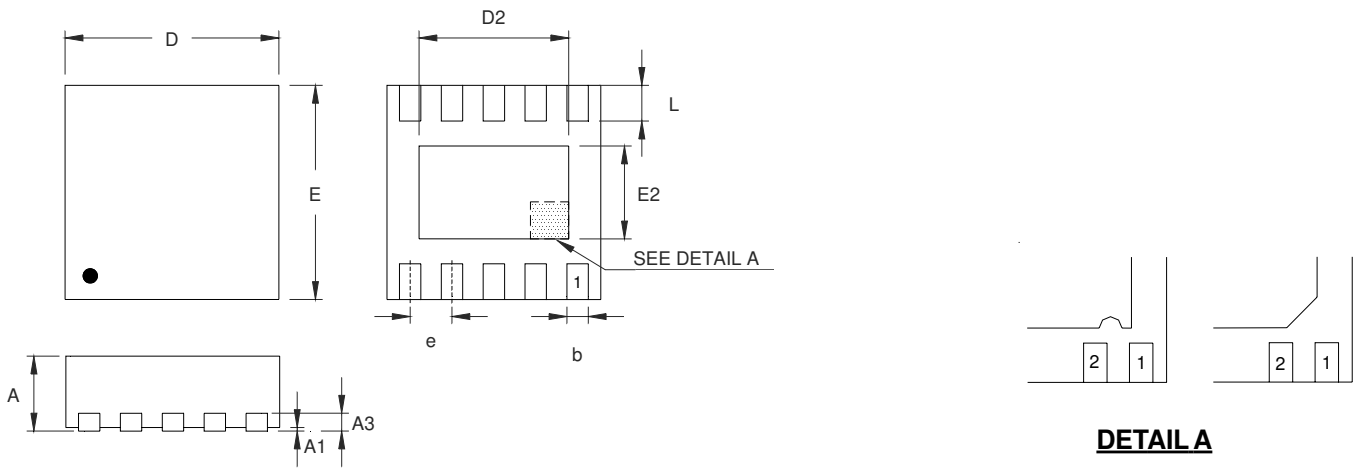

Figure 6. PCB Layout Guide

Outline Dimension



DETAIL A

Pin #1 ID and Tie Bar Mark Options

Note : The configuration of the Pin #1 identifier is optional, but must be located within the zone indicated.

Symbol	Dimensions In Millimeters		Dimensions In Inches	
	Min	Max	Min	Max
A	0.700	0.800	0.028	0.031
A1	0.000	0.050	0.000	0.002
A3	0.175	0.250	0.007	0.010
b	0.180	0.300	0.007	0.012
D	2.950	3.050	0.116	0.120
D2	2.300	2.650	0.091	0.104
E	2.950	3.050	0.116	0.120
E2	1.500	1.750	0.059	0.069
e	0.500		0.020	
L	0.350	0.450	0.014	0.018

W-Type 10L DFN 3x3 Package

Richtek Technology Corporation

Headquarter
 5F, No. 20, Taiyuen Street, Chupei City
 Hsinchu, Taiwan, R.O.C.
 Tel: (8863)5526789 Fax: (8863)5526611

Richtek Technology Corporation

Taipei Office (Marketing)
 5F, No. 95, Minchiuan Road, Hsintien City
 Taipei County, Taiwan, R.O.C.
 Tel: (8862)86672399 Fax: (8862)86672377
 Email: marketing@richtek.com

Information that is provided by Richtek Technology Corporation is believed to be accurate and reliable. Richtek reserves the right to make any change in circuit design, specification or other related things if necessary without notice at any time. No third party intellectual property infringement of the applications should be guaranteed by users when integrating Richtek products into any application. No legal responsibility for any said applications is assumed by Richtek.