

National Semiconductor is now part of  
Texas Instruments.

Search <http://www.ti.com/> for the latest technical  
information and details on our current products and services.

# LMC567

## Low Power Tone Decoder

### General Description

The LMC567 is a low power general purpose LMC MOS™ tone decoder which is functionally similar to the industry standard LM567. It consists of a twice frequency voltage-controlled oscillator (VCO) and quadrature dividers which establish the reference signals for phase and amplitude detectors. The phase detector and VCO form a phase-locked loop (PLL) which locks to an input signal frequency which is within the control range of the VCO. When the PLL is locked and the input signal amplitude exceeds an internally pre-set threshold, a switch to ground is activated on the output pin. External components set up the oscillator to run at twice the input frequency and determine the phase and amplitude filter time constants.

### Features

- Functionally similar to LM567
- 2V to 9V supply voltage range
- Low supply current drain
- No increase in current with output activated
- Operates to 500 kHz input frequency
- High oscillator stability
- Ground-referenced input
- Hysteresis added to amplitude comparator
- Out-of-band signals and noise rejected
- 20 mA output current capability

### Block Diagram (with External Components)

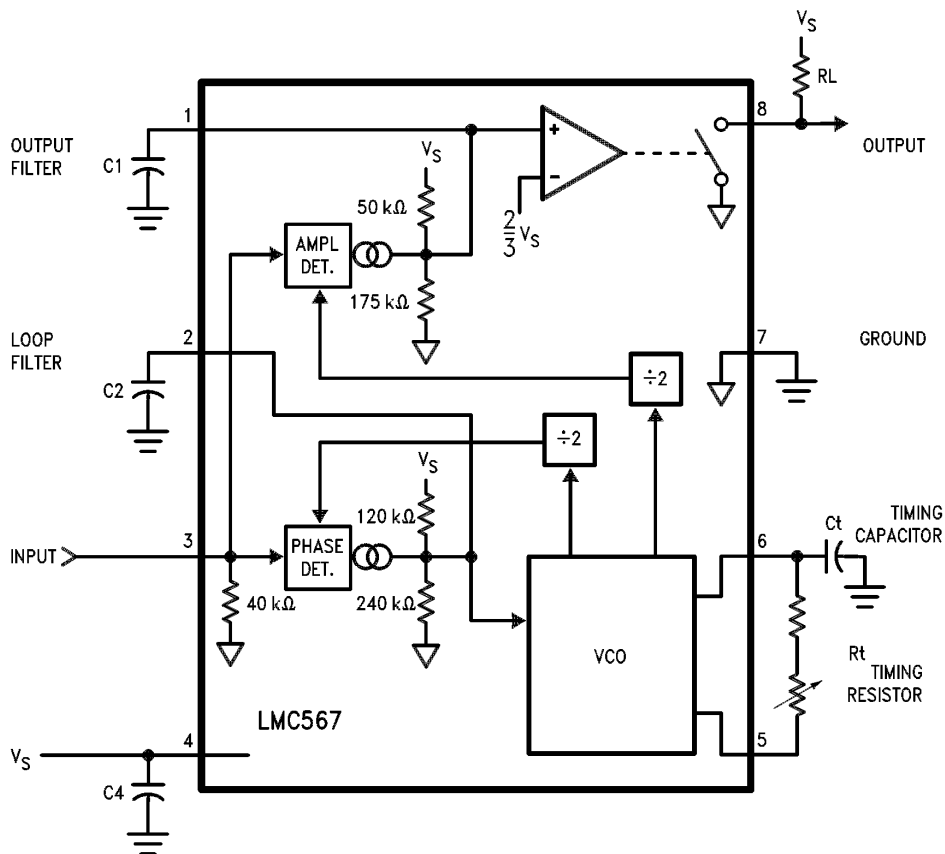

00867001

Order Number LMC567CM or LMC567CN  
See NS Package Number M08A or N08E

**Absolute Maximum Ratings** (Note 1)

If Military/Aerospace specified devices are required, please contact the National Semiconductor Sales Office/Distributors for availability and specifications.

|   |                       |
|---|-----------------------|
| Input Voltage, Pin 3                          | 2 V <sub>p-p</sub>    |
| Supply Voltage, Pin 4                         | 10V                   |
| Output Voltage, Pin 8                         | 13V                   |
| Voltage at All Other Pins                     | V <sub>s</sub> to Gnd |
| Output Current, Pin 8                         | 30 mA                 |
| Package Dissipation                           | 500 mW                |
| Operating Temperature Range (T <sub>A</sub> ) | -25°C to +125°C       |

Storage Temperature Range -55°C to +150°C

## Soldering Information

## Dual-In-Line Package

Soldering (10 sec.) 260°C

## Small Outline Package

Vapor Phase (60 sec.) 215°C

Infrared (15 sec.) 220°C

See AN-450 "Surface Mounting Methods and Their Effect on Product Reliability" for other methods of soldering surface mount devices.

**Electrical Characteristics**

Test Circuit, T<sub>A</sub> = 25°C, V<sub>s</sub> = 5V, RtCt #2, Sw. 1 Pos. 0, and no input, unless otherwise noted.

| Symbol           | Parameter                              | Conditions   | Min                 | Typ  | Max  | Units |       |
|------------------|--|--|---------------------|------|------|-------|-------|
| I4               | Power Supply Current                   | RtCt #1, Quiescent or Activated  | V <sub>s</sub> = 2V | 0.3  |      | mAdc  |       |
|                  |  |  | V <sub>s</sub> = 5V | 0.5  | 0.8  |       |       |
|                  |  |  | V <sub>s</sub> = 9V | 0.8  | 1.3  |       |       |
| V3               | Input D.C. Bias                        |  |                     | 0    |      | mVdc  |       |
| R3               | Input Resistance                       |  |                     | 40   |      | kΩ    |       |
| I8               | Output Leakage                         |  |                     | 1    | 100  | nAdc  |       |
| f <sub>0</sub>   | Center Frequency, F <sub>osc</sub> ÷ 2 | RtCt #2, Measure Oscillator Frequency and Divide by 2  | V <sub>s</sub> = 2V | 98   |      | kHz   |       |
|                  |  |  | V <sub>s</sub> = 5V | 92   | 103  |       | 113   |
|                  |  |  | V <sub>s</sub> = 9V |      | 105  |       |       |
| Δf <sub>0</sub>  | Center Frequency Shift with Supply     | $\frac{f_{0 9V} - f_{0 2V}}{7 f_{0 5V}} \times 100$  |                     | 1.0  | 2.0  | %/V   |       |
| V <sub>in</sub>  | Input Threshold                        | Set Input Frequency Equal to f <sub>0</sub> Measured Above, Increase Input Level Until Pin 8 Goes Low.                         | V <sub>s</sub> = 2V | 11   | 20   | 27    | mVrms |
|                  |  |  | V <sub>s</sub> = 5V | 17   | 30   | 45    |       |
|                  |  |  | V <sub>s</sub> = 9V |      | 45   |       |       |
| ΔV <sub>in</sub> | Input Hysteresis                       | Starting at Input Threshold, Decrease Input Level Until Pin 8 goes High.   |                     | 1.5  |      | mVrms |       |
| V8               | Output "Sat" Voltage                   | Input Level > Threshold<br>Choose RL for Specified I8  | I8 = 2 mA           | 0.06 | 0.15 | Vdc   |       |
|                  |  |  | I8 = 20 mA          | 0.7  |      |       |       |
| L.D.B.W.         | Largest Detection Bandwidth            | Measure F <sub>osc</sub> with Sw. 1 in Pos. 0, 1, and 2;<br>$L.D.B.W. = \frac{F_{osc P2} - F_{osc P1}}{F_{osc P0}} \times 100$ | V <sub>s</sub> = 2V | 7    | 11   | 15    | %     |
|                  |  |  | V <sub>s</sub> = 5V | 11   | 14   | 17    |       |
|                  |  |  | V <sub>s</sub> = 9V |      | 15   |       |       |
| ΔBW              | Bandwidth Skew                         | $Skew = \left( \frac{F_{osc P2} - F_{osc P1}}{2 F_{osc P0}} - 1 \right) \times 100$  |                     | 0    | ±1.0 | %     |       |
| f <sub>max</sub> | Highest Center Freq.                   | RtCt #3, Measure Oscillator Frequency and Divide by 2  |                     | 700  |      | kHz   |       |
| V <sub>in</sub>  | Input Threshold at f <sub>max</sub>    | Set Input Frequency Equal to f <sub>max</sub> measured Above, Increase Input Level Until Pin 8 goes Low.                       |                     | 35   |      | mVrms |       |

**Note 1:** Absolute Maximum Ratings indicate limits beyond which damage to the device may occur. Operating Ratings indicate conditions for which the device is functional, but do not guarantee specific performance limits. Electrical Characteristics state DC and AC electrical specifications under particular test conditions which guarantee specific performance limits. This assumes that the device is within the Operating Ratings. Specifications are not guaranteed for parameters where no limit is given, however, the typical value is a good indication of device performance.

# Test Circuit

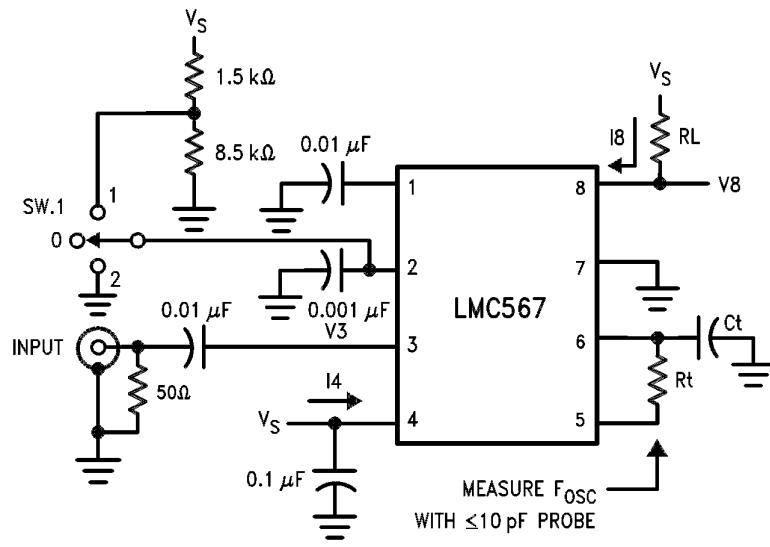

00867002

| RtCt | Rt   | Ct     |
|------|------|--------|
| #1   | 100k | 300 pF |
| #2   | 10k  | 300 pF |
| #3   | 5.1k | 62 pF  |

# Typical Performance Characteristics

**Supply Current vs. Operating Frequency**

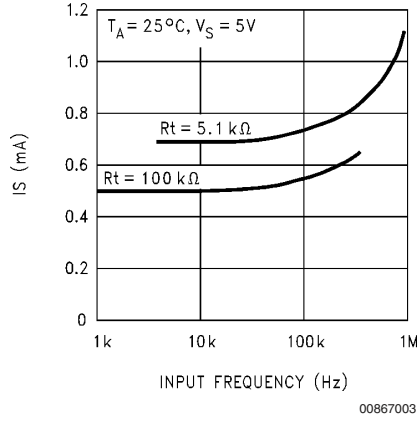

**Bandwidth vs. Input Signal Level**

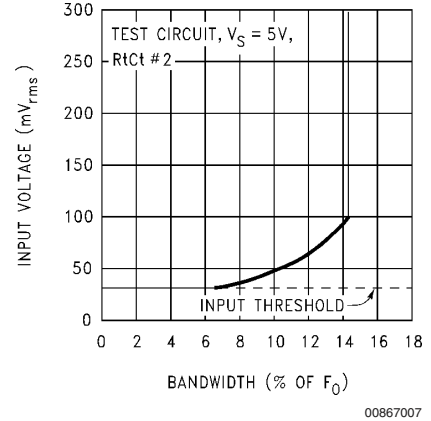

**Largest Detection Bandwidth vs. Temp.**

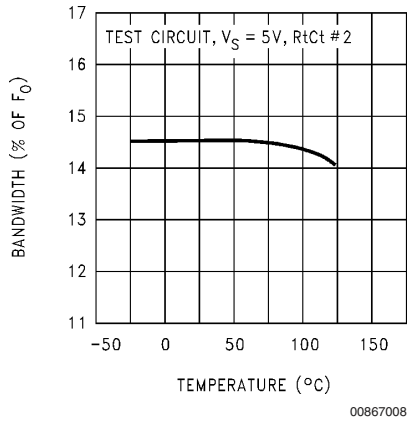

**Bandwidth as a Function of C2**

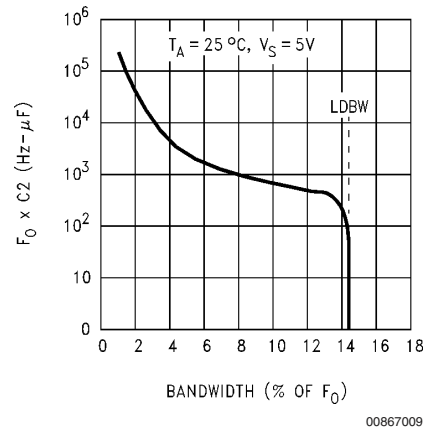

**Frequency Drift with Temperature**

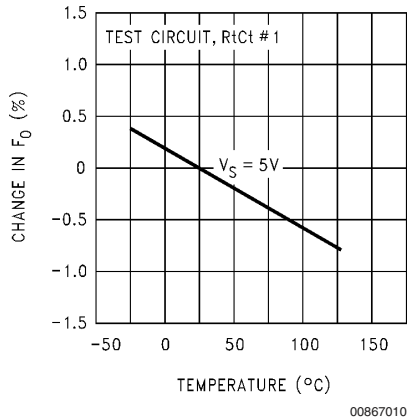

**Frequency Drift with Temperature**

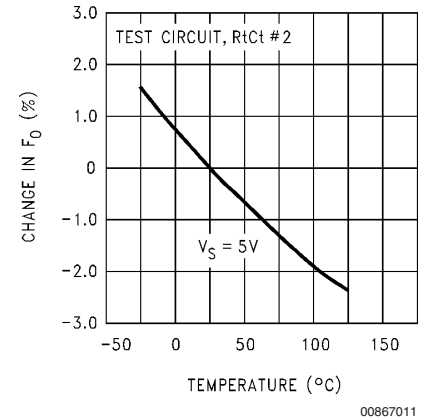

## Applications Information (refer to Block Diagram)

### GENERAL

The LMC567 low power tone decoder can be operated at supply voltages of 2V to 9V and at input frequencies ranging from 1 Hz up to 500 kHz.

The LMC567 can be directly substituted in most LM567 applications with the following provisions:

1. Oscillator timing capacitor  $C_t$  must be halved to double the oscillator frequency relative to the input frequency (See OSCILLATOR TIMING COMPONENTS).
2. Filter capacitors  $C_1$  and  $C_2$  must be reduced by a factor of 8 to maintain the same filter time constants.
3. The output current demanded of pin 8 must be limited to the specified capability of the LMC567.

### OSCILLATOR TIMING COMPONENTS

The voltage-controlled oscillator (VCO) on the LMC567 must be set up to run at twice the frequency of the input signal tone to be decoded. The center frequency of the VCO is set by timing resistor  $R_t$  and timing capacitor  $C_t$  connected to pins 5 and 6 of the IC. The center frequency as a function of  $R_t$  and  $C_t$  is given by:

$$F_{OSC} \cong \frac{1}{1.4 R_t C_t} \text{ Hz}$$

Since this will cause an input tone of half  $F_{osc}$  to be decoded,

$$F_{INPUT} \cong \frac{1}{2.8 R_t C_t} \text{ Hz}$$

This equation is accurate at low frequencies; however, above 50 kHz ( $F_{osc} = 100$  kHz), internal delays cause the actual frequency to be lower than predicted.

The choice of  $R_t$  and  $C_t$  will be a tradeoff between supply current and practical capacitor values. An additional supply current component is introduced due to  $R_t$  being switched to  $V_s$  every half cycle to charge  $C_t$ :

$$I_s \text{ due to } R_t = V_s / (4R_t)$$

Thus the supply current can be minimized by keeping  $R_t$  as large as possible (see supply current vs. operating frequency curves). However, the desired frequency will dictate an  $R_t C_t$  product such that increasing  $R_t$  will require a smaller  $C_t$ . Below  $C_t = 100$  pF, circuit board stray capacitances begin to play a role in determining the oscillation frequency which ultimately limits the minimum  $C_t$ .

To allow for I.C. and component value tolerances, the oscillator timing components will require a trim. This is generally accomplished by using a variable resistor as part of  $R_t$ , although  $C_t$  could also be padded. The amount of initial frequency variation due to the LMC567 itself is given in the electrical specifications; the total trim range must also accommodate the tolerances of  $R_t$  and  $C_t$ .

### SUPPLY DECOUPLING

The decoupling of supply pin 4 becomes more critical at high supply voltages with high operating frequencies, requiring  $C_4$  to be placed as close as possible to pin 4.

### INPUT PIN

The input pin 3 is internally ground-referenced with a nominal 40 k $\Omega$  resistor. Signals which are already centered on 0V may be directly coupled to pin 3; however, any d.c. potential must be isolated via a coupling capacitor. Inputs of multiple LMC567 devices can be paralleled without individual d.c. isolation.

### LOOP FILTER

Pin 2 is the combined output of the phase detector and control input of the VCO for the phase-locked loop (PLL). Capacitor  $C_2$  in conjunction with the nominal 80 k $\Omega$  pin 2 internal resistance forms the loop filter.

For small values of  $C_2$ , the PLL will have a fast acquisition time and the pull-in range will be set by the built in VCO frequency stops, which also determine the largest detection bandwidth (LDBW). Increasing  $C_2$  results in improved noise immunity at the expense of acquisition time, and the pull-in range will begin to become narrower than the LDBW (see Bandwidth as a Function of  $C_2$  curve). However, the maximum hold-in range will always equal the LDBW.

### OUTPUT FILTER

Pin 1 is the output of a negative-going amplitude detector which has a nominal 0 signal output of  $7/9 V_s$ . When the PLL is locked to the input, an increase in signal level causes the detector output to move negative. When pin 1 reaches  $2/3 V_s$  the output is activated (see OUTPUT PIN).

Capacitor  $C_1$  in conjunction with the nominal 40 k $\Omega$  pin 1 internal resistance forms the output filter. The size of  $C_1$  is a tradeoff between slew rate and carrier ripple at the output comparator. Low values of  $C_1$  produce the least delay between the input and output for tone burst applications, while larger values of  $C_1$  improve noise immunity.

Pin 1 also provides a means for shifting the input threshold higher or lower by connecting an external resistor to supply or ground. However, reducing the threshold using this technique increases sensitivity to pin 1 carrier ripple and also results in more part to part threshold variation.

### OUTPUT PIN

The output at pin 8 is an N-channel FET switch to ground which is activated when the PLL is locked and the input tone is of sufficient amplitude to cause pin 1 to fall below  $2/3 V_s$ . Apart from the obvious current component due to the external pin 8 load resistor, no additional supply current is required to activate the switch. The on resistance of the switch is inversely proportional to supply; thus the "sat" voltage for a given output current will increase at lower supplies.

**Physical Dimensions** inches (millimeters) unless otherwise noted

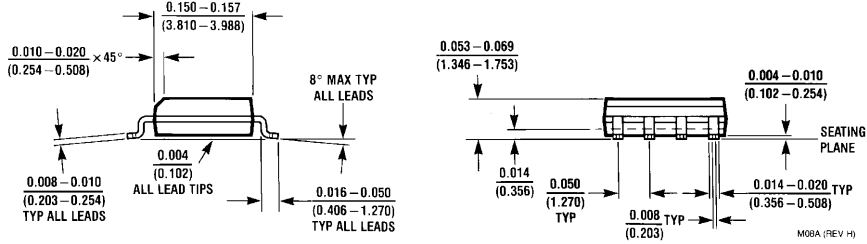
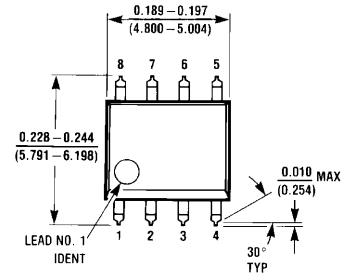

**Molded Small Outline (SO) Package (M)**  
**Order Number LMC567CM**  
**NS Package Number M08A**

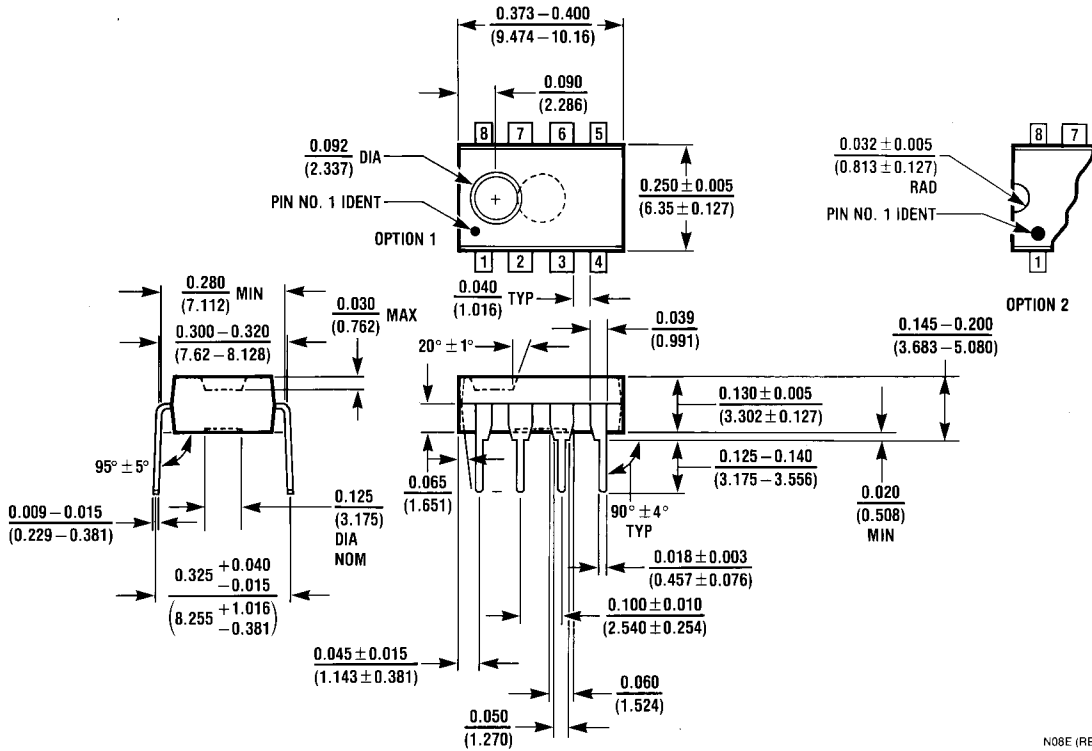

**Molded Dual-In-Line Package (N)**  
**Order Number LMC567CN**  
**NS Package Number N08E**

## Notes

National does not assume any responsibility for use of any circuitry described, no circuit patent licenses are implied and National reserves the right at any time without notice to change said circuitry and specifications.

For the most current product information visit us at [www.national.com](http://www.national.com).

### LIFE SUPPORT POLICY

NATIONAL'S PRODUCTS ARE NOT AUTHORIZED FOR USE AS CRITICAL COMPONENTS IN LIFE SUPPORT DEVICES OR SYSTEMS WITHOUT THE EXPRESS WRITTEN APPROVAL OF THE PRESIDENT AND GENERAL COUNSEL OF NATIONAL SEMICONDUCTOR CORPORATION. As used herein:

1. Life support devices or systems are devices or systems which, (a) are intended for surgical implant into the body, or (b) support or sustain life, and whose failure to perform when properly used in accordance with instructions for use provided in the labeling, can be reasonably expected to result in a significant injury to the user.
2. A critical component is any component of a life support device or system whose failure to perform can be reasonably expected to cause the failure of the life support device or system, or to affect its safety or effectiveness.

### BANNED SUBSTANCE COMPLIANCE

National Semiconductor certifies that the products and packing materials meet the provisions of the Customer Products Stewardship Specification (CSP-9-111C2) and the Banned Substances and Materials of Interest Specification (CSP-9-111S2) and contain no "Banned Substances" as defined in CSP-9-111S2.



**National Semiconductor**  
Americas Customer  
Support Center  
Email: [new.feedback@nsc.com](mailto:new.feedback@nsc.com)  
Tel: 1-800-272-9959

**National Semiconductor**  
Europe Customer Support Center  
Fax: +49 (0) 180-530 85 86  
Email: [europe.support@nsc.com](mailto:europe.support@nsc.com)  
Deutsch Tel: +49 (0) 69 9508 6208  
English Tel: +44 (0) 870 24 0 2171  
Français Tel: +33 (0) 1 41 91 8790

**National Semiconductor**  
Asia Pacific Customer  
Support Center  
Email: [ap.support@nsc.com](mailto:ap.support@nsc.com)

**National Semiconductor**  
Japan Customer Support Center  
Fax: 81-3-5639-7507  
Email: [jpn.feedback@nsc.com](mailto:jpn.feedback@nsc.com)  
Tel: 81-3-5639-7560