

PQ50/PQ50S/PQ50W Series

Power Supply/Signal Connectors for Industrial Equipment



Robust



Positive-Lock



Waterproof



Overview

The PQ Series is an interface connector designed to handle high power/signal connections in industrial equipment. Available in a waterproof or non-waterproof type, they are capable of handling up to 12.5A/pin (PQ50S/PQ50W) or 19A/pin (PQ50).



Variations

Features

[Non-Waterproof Type] PQ50/PQ50S Series

1. Side locking spring design delivers a clear tactile click.

The left and right buttons disengage the mated lock. (Side locking system)
The easy mating operation delivers a clear tactile click.

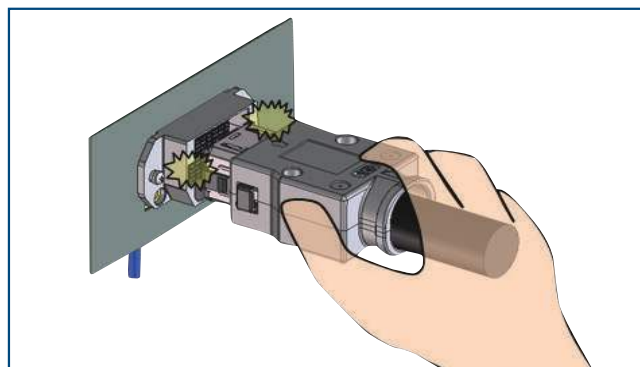

Side locking design emits a tactile click and produces a secure lock

2. Strengthened Cable Clamps

Cable clamp strength is 98N or more.
(Actual value is 400N or more)
The design prevents the mated connector and clamp from detaching against excessive forces.

3. Different cover options. A robust, enhanced, shielded die-cast shell is available on the PQ50-20pos./PQ50S-36pos. or a engineered, light weight plated plastic resin shell for the PQ50S-48pos.

The die cast shell delivers an enhanced EMI shield on the PQ50-20pos./PQ50S-36pos. and the plated plastic resin of the PQ50S-48pos. cover case and panel shell ensure ESD and EMI performance.

4. Coding key system provides flexibility with multiple options.

The coding key system prevents incorrect mating and has multiple variations available.

5. Rear mounted panel shell is available.

After attaching the panel shell to the chassis, it is possible to install or remove the crimp housing.

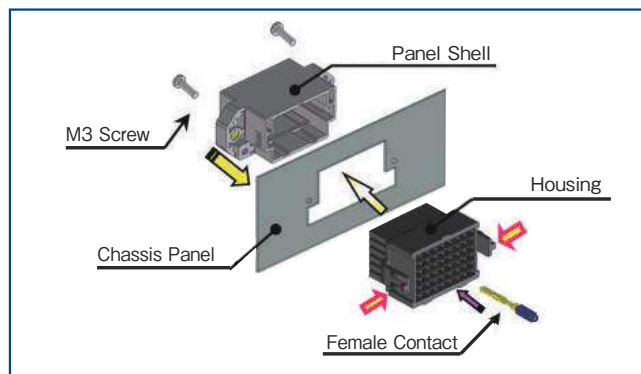

It is possible to insert the terminated housing from the rear.

6. Reliable ground connection design.

The crimp contacts can be mounted directly onto the panel shell with screws which enhances the grounding connections.

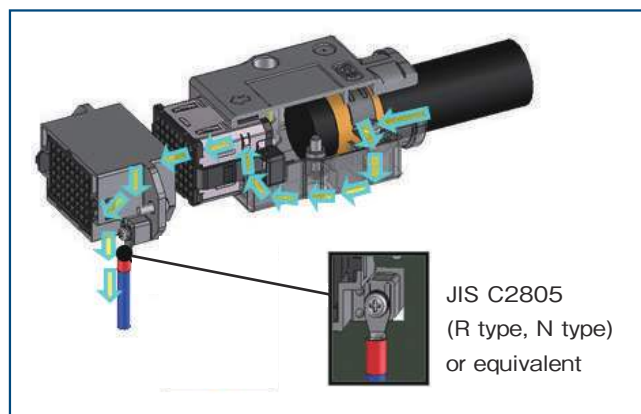

Easy and Reliable Ground Connection

7. Supports NFPA79 compliant cables (with 600V capability).

(PQ50 Series)

Due to restrictions on the AWM cables by NFPA79 revision, the requirements of listed cables has increased for wires used in industrial machines in the U.S.A. This product complies with the restrictions and requirements of NFPA79.

[Waterproof Type] PQ50W Series

1. Water Resistant (IP65)

Rated at IP65 when in the mated condition.

2. Special locking design.

Special lever and cam design delivers easier operation and assists with the insertion and extraction of this connector.



Unique Lever Lock Design

3. Rear mounted unit offers easy operations.

Male and Female plastic crimp case can be installed from both the panel side metal shell and plug side.

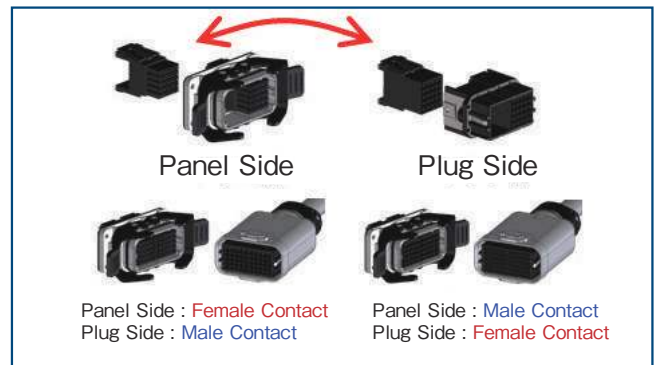

Supports Rear Mounting of Unit

4. Metal plated cover with engineering plastic resin adds strength and EMI protection.

This robust connector uses a metal plated material with specially engineered plastic for the cover and panel shell to ensure high ESD and EMI performance.

5. Independent ground contact design.

Secure grounding is accomplished by use of the plated plastic cover and the independent ground contacts.

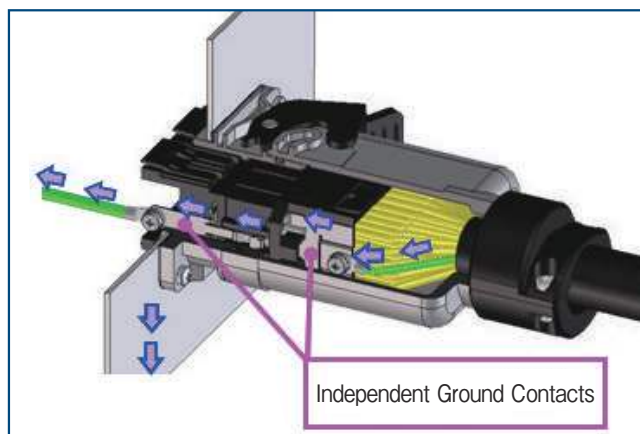

Independent ground contact design.

6. Coding Key System Provides Flexibility with Multiple Options

The coding key system prevents incorrect mating and has multiple variations available.

[Contact Variations]

1. Available Contact Options

Two styles are available; one with 19A/pin contacts or one with 12.5A/pin contacts.

2. Lance Protection Design

The wall on the side of the contact prevents lance deformation and entanglement between contacts.

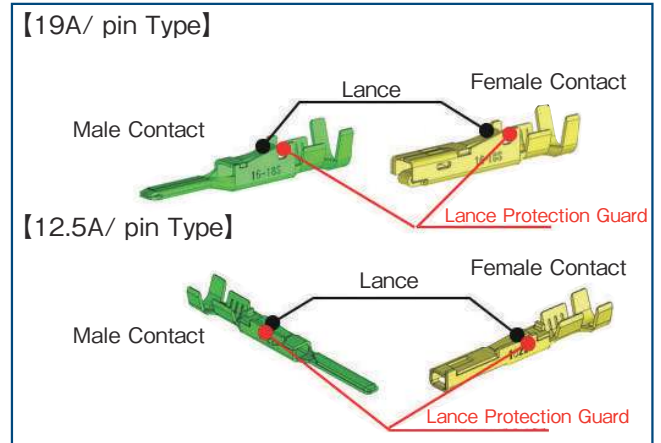

Lance protection design

3. Sequential Contacts of Different Length are Available

Two types of different contact length are available for the male contact.

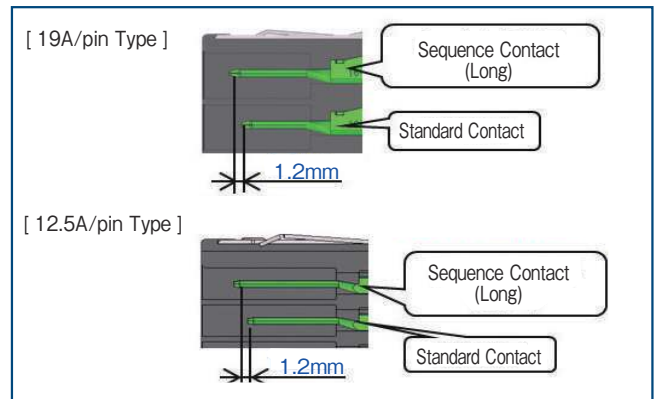

Sequential Contacts with Differing Lengths

4. Highly Reliable Contact Design

Multi-point female contact with spring design provides high contact reliability.

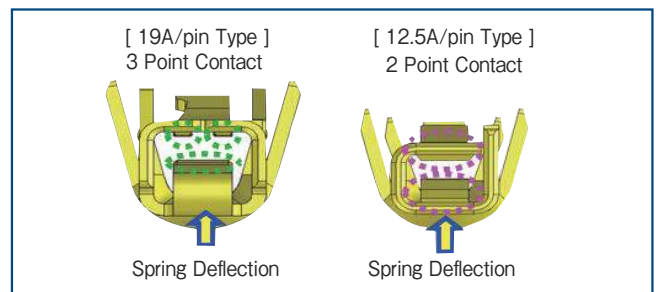

Multiple contact points and flexible spring design

5. Can Use Contacts Between Multiple Series

The contacts for PQ50WA and PQ50WT are inter-compatible. The crimping equipment and parts can also be used interchangeably.

Product Specifications

[Non-waterproof Type] PQ50 Series

Rated Current	with UL1015, 16 AWG (Note 1)	Operating Temperature (Note 2)	-40 to +105°C
	19A	Storage Temperature	-55 to +85°C
Rated Voltage	600V AC/DC		

Note 1 : Depends on cable current capacity.

Note 2 : Includes temperature rise due to current flow.

Items	Specifications	Conditions
Contact Resistance	10m Ω Max. (Excluding conductor resistance of the cable.)	Measured at 100mA
Insulation Resistance	Minimum of 5,000M Ω	Measured at 500V DC
Withstand Voltage	No insulation breakdown	Apply 2,200V AC for 1 min.
Mating Durability	Contact resistance : Increase by 20m Ω or less from the initial value.	500 times
Vibration Resistance	No electrical discontinuity of 10 μs or more. No broken, cracked or loosened parts.	Frequency 10 to 55Hz (5 min/cycle). With half amplitude 0.75mm, 2 hours each for 3 directions.
Shock Resistance		Acceleration : 490m/s ² , Duration : 11ms, Sine Half-wave : 3 times each in 6 axial directions
Temperature Cycles	Change of contact resistance : 20m Ω or less No broken, cracked or loosened parts.	Temperature : -55 → +15 to 35 → +105 → +15 to +35°C Time : 30 → 2 to 3 → 30 → 2 to 3 min. for 5cycles
Moisture Resistance in Steady State	Change of contact resistance : 20m Ω Max. Insulation resistance: minimum of 1,000M Ω (after drying). No breakage, cracks or loosened parts.	Left in environment of 60°C± 2 and humidity of 90 to 95% for 96 hours.
Salt Water Spray	No significant corrosion or damage that impairs functioning.	5% concentration of salt water spray for 48 hours.(in mated condition)

Note : For test methods not described here, JIS C 5402 is applied.

[Non-waterproof Type] PQ50S Series

Rated Current	with UL1007, 18 AWG (Note 1)	Operating Temperature (Note 2)	-40 to +105°C
	12.5A	Storage Temperature	-55 to +85°C
Rated Voltage	300V AC/DC		

Note 1 : Depends on cable current capacity.

Note 2 : Includes temperature rise due to current flow.

Items	Specifications	Conditions
Contact Resistance	5mΩ Max. (Excluding conductor resistance of the cable.)	Measured at 100mA
Insulation Resistance	Minimum of 5,000MΩ	Measured at 500V DC
Withstand Voltage	No insulation breakdown	Apply 2,200V AC for 1 min.
Mating Durability	Contact resistance : Increase by 10mΩ or less from the initial value.	500 times
Vibration Resistance	No electrical discontinuity of 10 μs or more. No broken, cracked or loosened parts.	Frequency 10 to 55Hz (5 min/cycle) With half amplitude 0.75mm, 2 hours each for 3 directions.
Shock Resistance		Acceleration : 490m/s ² , Duration : 11ms, Sine Half-wave : 3 times each in 6 axial directions
Temperature Cycles	Change of contact resistance : 10mΩ or less No broken, cracked or loosened parts.	Temperature : -55 → +15 to 35 → +105 → +15 to +35°C Time : 30 → 2 to 3 → 30 → 2 to 3 min. for 5cycles
Moisture Resistance in Steady State	Change of contact resistance : 10mΩ or less Insulation resistance : Minimum of 1,000MΩ (after drying). No broken, cracked or loosened parts.	Left in environment of 60°C± 2 and humidity of 90 to 95% for 96 hours.
Salt Water Spray	No significant corrosion or damage that impairs functioning.	5% concentration of salt water spray for 48 hours. (in mated condition)

Note : For test methods not described here, JIS C 5402 is applied.

[Waterproof Type] PQ50W Series

Rated Current	with UL1007, 18 AWG (Note 1)	Operating Temperature (Note 2)	-40 to +105°C
	12.5A	Storage Temperature	-55 to +85°C
Rated Voltage	300V AC/DC		

Note 1 : Depends on cable current capacity. (With 12.5A/pin type contacts)

Note 2 : Includes temperature rise due to current flow.

Items	Specifications	Conditions
Contact Resistance	5mΩ max (Excluding conductor resistance of the cable.)	Measured at 100mA
Insulation Resistance	Minimum of 5,000MΩ	Measured at 500V DC
Withstand Voltage	No insulation breakdown	Apply 2,200V AC for 1 min..
Mating Durability	Contact resistance : Increase by 10mΩ or less from the initial value.	500 times
Vibration Resistance	No electrical discontinuity of 10 μs or more. No broken, cracked or loosened parts.	Frequency 10 to 55Hz (5 min/cycle) With half amplitude 0.75mm, 2 hours each for 3 directions.
Shock Resistance		Acceleration : 490m/s ² , Duration : 11ms, Sine Half-wave : 3 times each in 6 axial directions
Temperature Cycles	Change of contact resistance : 10mΩ or less No broken, cracked or loosened parts.	Temperature : -55 → +15 to 35 → +105 → +15 to +35°C Time : 30 → 2 to 3 → 30 → 2 to 3 min. for 5cycles
Moisture Resistance in Steady State	Change of contact resistance : 10mΩ or less Insulation resistance : 1,000MΩ or more (after drying) No broken, cracked or loosened parts.	Left in environment of 60°C±2 and humidity of 90 to 95% for 96 hours.
Salt Water Spray	No significant corrosion or damage that impairs functioning.	5% concentration of salt water spray for 48 hours. (in mated condition)
Water Resistance	IP65	

Note : For test methods not described here, JIS C 5402 is applied.

Materials / Finish

● PQ50 Series, PQ50S-36pos. Type

Item	Parts	Materials	Finish	Remarks
Receptacle	Crimp Case	PBT Resin	Black	UL94V-0
	Panel Shell	Zinc Die Cast	Nickel Plating	-
Plug	Crimp Case	PBT Resin	Black	UL94V-0
	Crimp Case Shell	Stainless Steel	Nickel Plating	-
	Cover Case	Zinc Die Cast		
	M4 Pan Head Machine Screw	Steel		
	Clamp Metal	Steel		
In-line Plug	Crimp Case	PBT Resin	Black	UL94V-0
	In-line Plug Shell	Zinc Die Cast	Nickel Plating	-
	In-line Cover Case			
	M4 Pan Head Machine Screw	Steel		
	Clamp Metal	Steel		

● PQ50S-48pos. Type

Item	Parts	Materials	Finish	Remarks
Receptacle	Crimp Case	PBT Resin	Black	UL94V-0
	Panel Shell	Heat-resistant Engineering Plastic Resin	Nickel Plating	-
	M4 Insert Nut	Brass		
Plug	Crimp Case	PBT Resin	Black	UL94V-0
	Crimp Case Shell	Stainless Steel	Nickel Plating	-
	Cover Case	Heat-resistant Engineering Plastic Resin		UL94V-0
	M4 Pan Head Machine Screw	Steel		-
	Clamp Metal	Steel		-
	M4 Insert Nut	Brass	-	
Right Angle Plug	Crimp Case	PBT Resin	Black	UL94V-0
	Crimp Case Shell	Stainless Steel	Nickel Plating	-
	Cover Case	Heat-resistant Engineering Plastic Resin		UL94V-0
	M4 Pan Head Machine Screw	Steel	-	
	Cable Clamp	PBT Resin	Black	UL94V-0
	M4 Insert Nut	Brass	Nickel Plating	-

Jul11.2023 Copyright 2023 HRS ELECTRIC CO., LTD. All Rights Reserved.

● PQ50W Series

Item	Parts	Materials	Finish	Remarks
Crimp case	Crimp Case	PBT Resin	Black	UL94V-0
Receptacle	Panel Shell	Heat-resistant Engineering Plastic Resin	Nickel Plating	UL94V-0
	Ground Contact	Stainless Steel		-
	O-ring for Mating	NBR	Black	UL94V-0
	Lock Lever	PA Resin		-
	Rubber Packing	NBR		-
Plug	Plug Shell	Heat-resistant Engineering Plastic Resin	Black	UL94V-0
	Ground Contact	Stainless Steel	Nickel Plating	-
	M2 Tapping Screw	Steel	Trivalent Chromate	
	Cover Case		Nickel Plating	
	Gasket	NBR	Red	
	Clamp Metal (Body)	Heat-resistant Engineering Plastic Resin	Black	UL94V-0
	Cable Clamp			
	M4 Insert Nut	Brass	Nickel Plating	-
	M3 Pan Head Machine Screw	Steel		

● Contacts (PQ50/PQ50S/PQ50W)

Part No.	Parts	Materials	Finish
PQ50-15PCFA	Male Contact	Copper Alloy	Gold Plating (Contact Area) + Tin Plating (Barrel Area)
PQ50A-15PCFA			
PQ50-15SCFA	Female Contact		
PQ50-1618PCFA	Male Contact		
PQ50A-1618PCFA			
PQ50-1618SCFA	Female Contact		
PQ50-2022PCFA	Male Contact		
PQ50A-2022PCFA			
PQ50-2022SCFA	Female Contact		
PQ50S-1822PCFA	Male Contact		
PQ50SA-1822PCFA			
PQ50S-1822SCFA	Female Contact		
PQ50S-2428PCFA	Male Contact		
PQ50SA-2428PCFA			
PQ50S-2428SCFA	Female Contact		

Product Number Structure

Refer to the chart below when determining the product specifications from the product number.
Please select from the product numbers listed in this catalog when placing orders.

■ Crimp Housing

PQ 50 W S - 25 P - UNIT

① ② ③ ④ ⑤ ⑥ ⑦

① Series Name	PQ	⑤ Shell Size	20 : 20pos. unit 25 : 25pos. unit 48 : 48pos. unit
② Termination Style	Crimping	⑥ Contact Gender	P : Male Contact S : Female Contact
③ Connector Specifications	W : Waterproof Type None : Non-waterproof Type	⑦ Body	UNIT : Rear mount multiple unit (PQ50W) None : Rear mount multiple unit (PQ50, PQ50S)
④ Contact Size	S : Small Contact (12.5A/pin) Type None : Standard Contact (19A/pin) Type		

■ Crimp Contact

PQ 50 S A - 1822 PC F A

① ② ③ ④ ⑤ ⑥ ⑦ ⑧

① Series Name	PQ	⑤ Applicable Cable Type	15 : 14 to 15 AWG 1618 : 16 to 18 AWG 1822 : 18 to 22 AWG 2022 : 20 to 22 AWG 2428 : 24 to 28 AWG
② Termination Style	Crimping	⑥ Contact Gender	PC : Male Contact SC : Female Contact
③ Contact Size	S : Small Contact (12.5A/pin) Type None : Standard Contact (19A/pin) Type	⑦ Contact Shapes	F : Reel Contact None : Loose Contact
④ Contact Usage	A : Sequence Contact (Long Contact) None : Standard Contact	⑧ Contact Plating Type	A : Gold Plating (Contact Area)

■ Clamp Metal, Cable Clamp

PQ W - CM (17.5)

① ② ③ ④

① Series Name	PQ	④ Applicable Cable Diameter	(15.0) : For applicable cable diameter ϕ 15.0 (17.5) : For applicable cable diameter ϕ 17.5 (22.0) : For applicable cable diameter ϕ 22.0
② Connector Specifications	W : Waterproof Type None : Non-waterproof Type		
③ Clamp Name	CM : Clamp Metal, Cable Clamp CML : Cable Clamp for Right Angle		

■ PQ50/PQ50S Series

PQ 50 S - 48 P - PC MA

① ② ③ ④ ⑤ ⑥ ⑦

① Series Name	PQ	⑤ Contact Gender	P : Male Contact S : Female Contact
② Termination Style	Crimping		
③ Contact Size	S : Small Contact (12.5A/pin) Type None : Standard Contact (19A/pin) Type	⑥ Case Type	PC : Plug Cover Case JC : In-line Plug Cover Case FL : Panel Shell DS : In-line Plug Shell PCL : Right Angle Plug Cover Case
④ Shell Size	20 : 20pos. Shell Type 48 : 48pos. Shell Type		
		⑦ Case Material	MA : Heat-resistant Engineering Plastic Resin None : Zinc Die Cast

■ PQ50W Series

PQ 50 W - 50 - PCA

① ② ③ ④ ⑤

① Series Name	PQ	④ Shell Size	50 : 50pos. Shell Type
② Termination Style	Crimping	⑤ Case Type	PCA : Plug Cover Case FLA : Panel Shell
③ Connector Specifications	Waterproof Type		

Functional Diagram

● PQ50 Series, PQ50S-36pos. Type

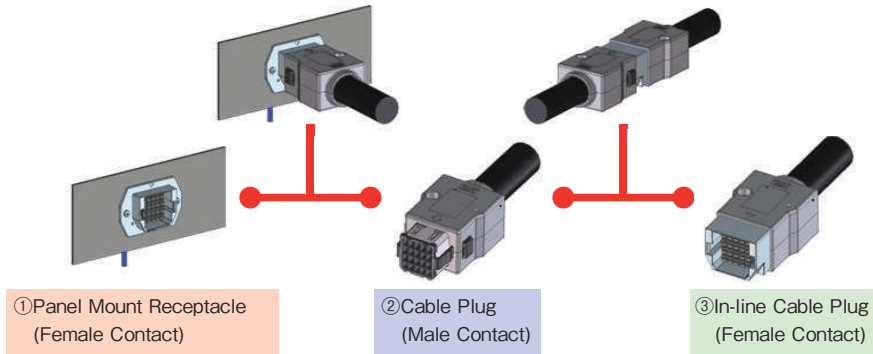

● PQ50S-48pos. Type

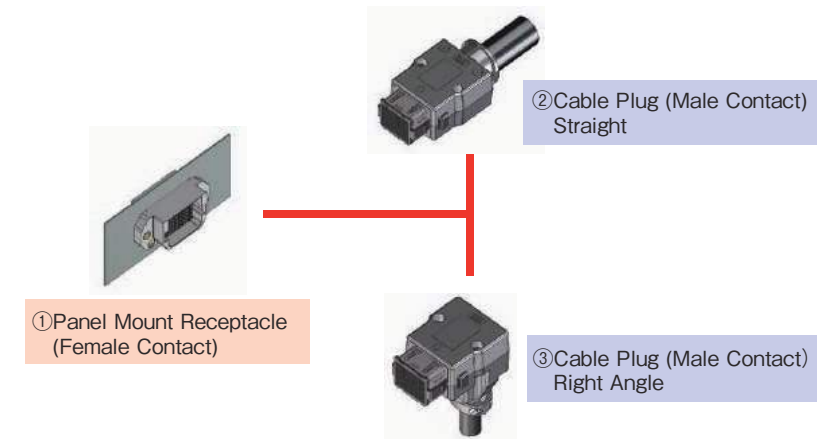

● PQ50W Series

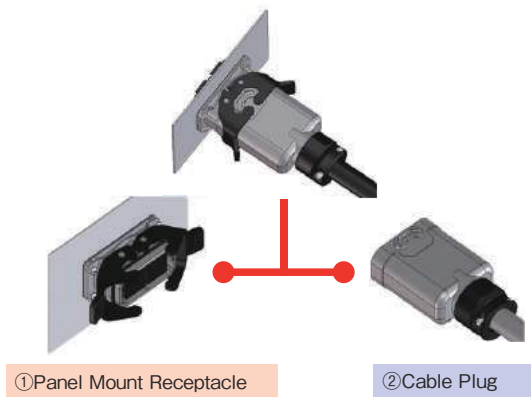

Panel Mount Receptacle

PQ50 Series

●Crimp Case (19A/pin for Female Contact)

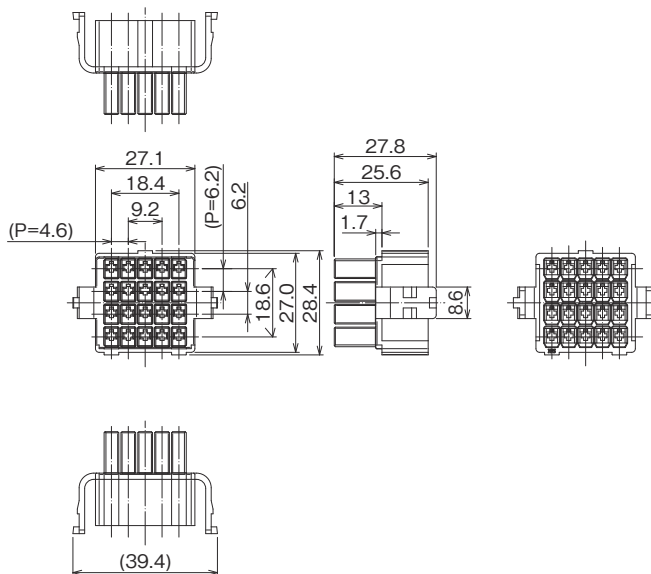

Part No.	HRS No.	Purchase Unit
PQ50-20S	CL0236-2014-2-00	50pcs per box
PQ50-20S(01)	CL0236-2014-2-01	1pc per box

● Panel Shell

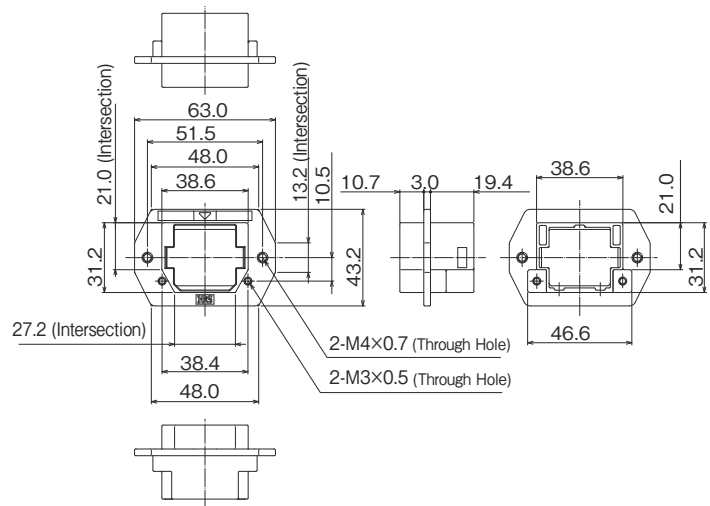

Panel Mounting Dimensions

Recommended panel dimensions for attaching panel shell from panel's front side.

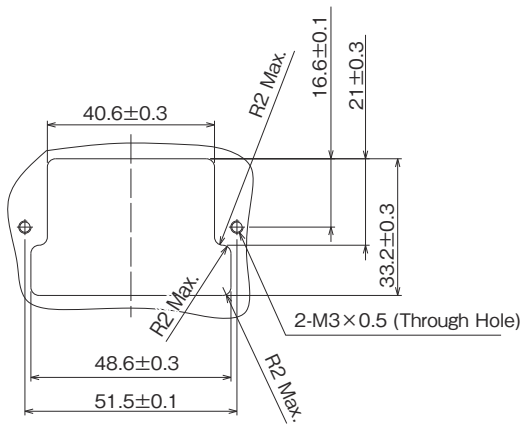

Recommended panel dimensions for attaching panel shell from panel's back side.

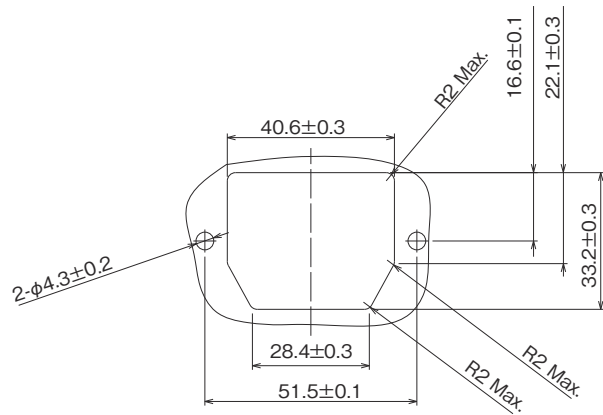

Part No.	HRS No.	Purchase Unit
PQ50-20S-FL	CL0236-2001-0-00	50pcs per box
PQ50-20S-FL(01)	CL0236-2001-0-01	1pc per box

Cable Plug

PQ50 Series

●Crimp Case (19A/pin for Male Contact)

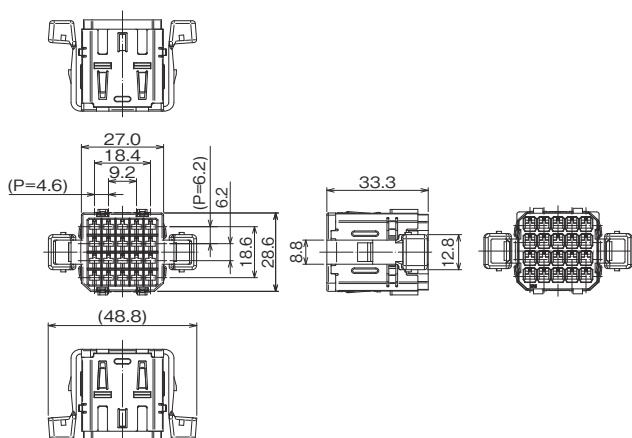

Part No.	HRS No.	Purchase Unit
PQ50-20P	CL0236-2011-4-00	50pcs per box
PQ50-20P(01)	CL0236-2011-4-01	1pc per box

●Plug Cover Case

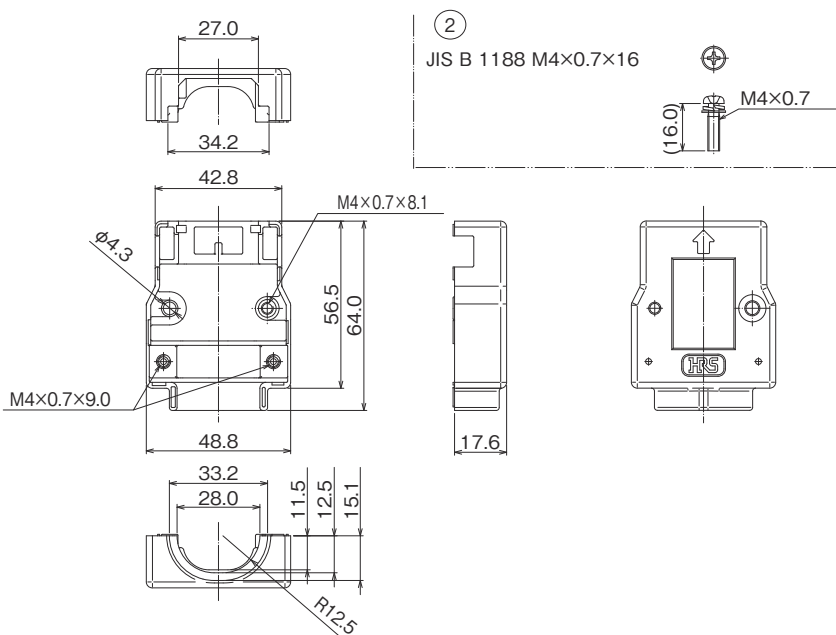

Part No.	HRS No.	Purchase Unit	Remarks
PQ50-20P-PC	CL0236-2000-8-00	100pcs per box	Use 2pcs per set. 50 sets of plug cover cases.
PQ50-20P-PC(01)	CL0236-2000-8-01	2pcs per box	1 set of plug cover case

In-Line Cable Plug

PQ50 Series

● In-line Plug Cover Case

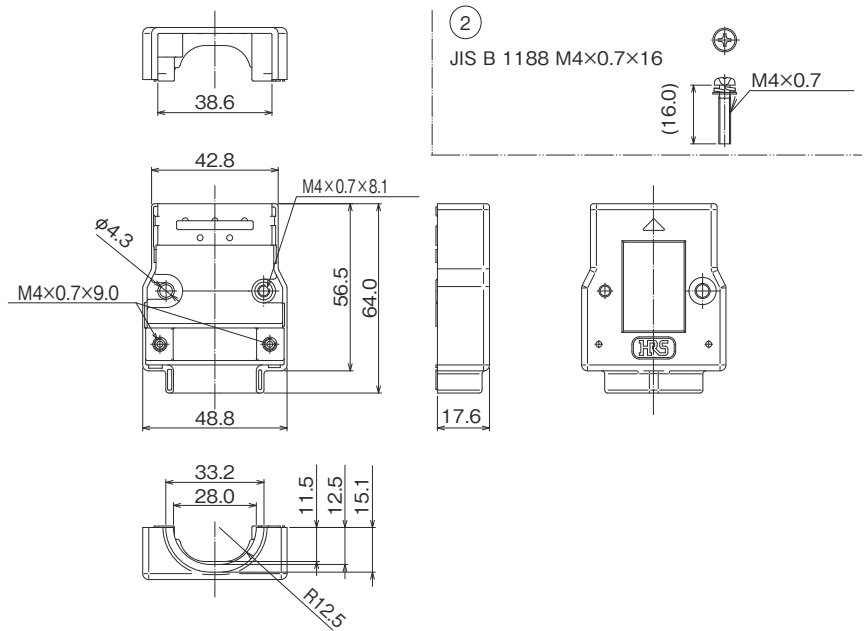

Part No.	HRS No.	Purchase Unit	Remarks
PQ50-20S-JC	CL0236-2002-3-00	100pcs per box	Use 2pcs per set. 50 sets of In-line plug cover cases.
PQ50-20S-JC(01)	CL0236-2002-3-01	2pcs per box	1 set of In-line plug cover case

● In-line Plug Shell

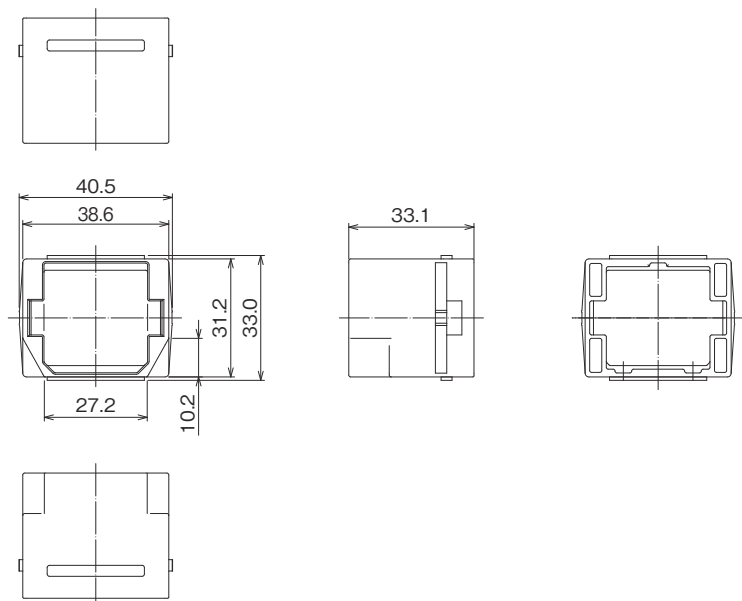

Part No.	HRS No.	Purchase Unit
PQ50-20S-DS	CL0236-2015-5-00	50pcs per box
PQ50-20S-DS(01)	CL0236-2015-5-01	1pc per box

Cable Plug

PQ50S-36pos. Type

- Crimp Case (12.5A/pin for Male Contact)

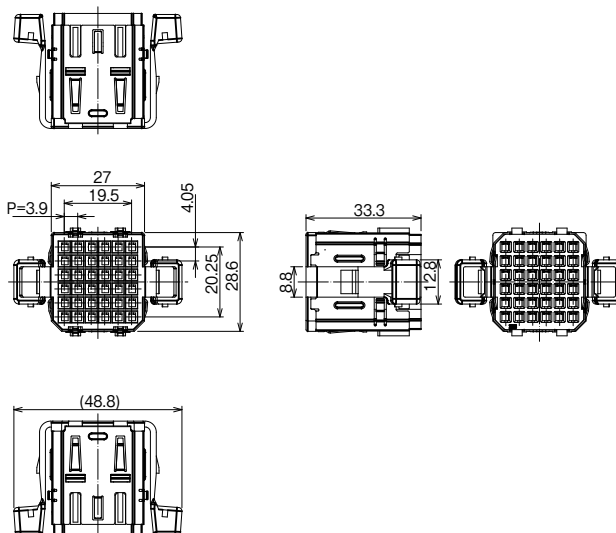

Part No.	HRS No.	Purchase Unit
PQ50S-36P	CL0236-2123-0-00	50pcs per box

Note : For the cover case, select PQ50-20P-PC for the PQ50 Series.

Panel Mount Receptacle

PQ50S-36pos. Type

- Crimp Case (12.5A/pin for Female Contact)

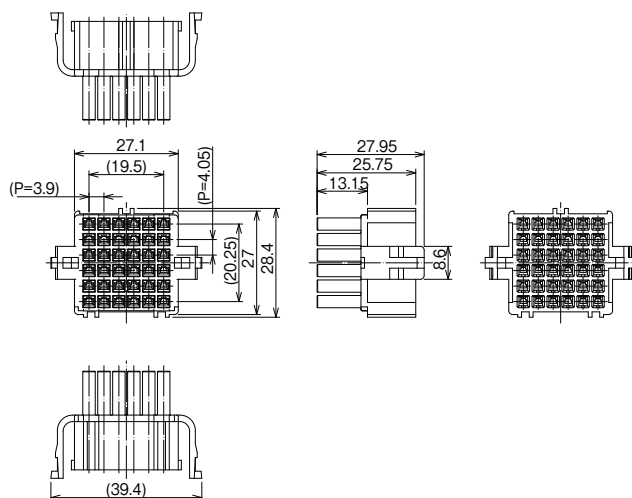

Part No.	HRS No.	Purchase Unit
PQ50S-36S	CL0236-2122-0-00	50pcs per box

Note : For the cover case, select PQ50-20S-FL for the PQ50 Series.

Cable Plug

PQ50S-48pos. Type

●Crimp Case (12.5A/pin for Male Contact)

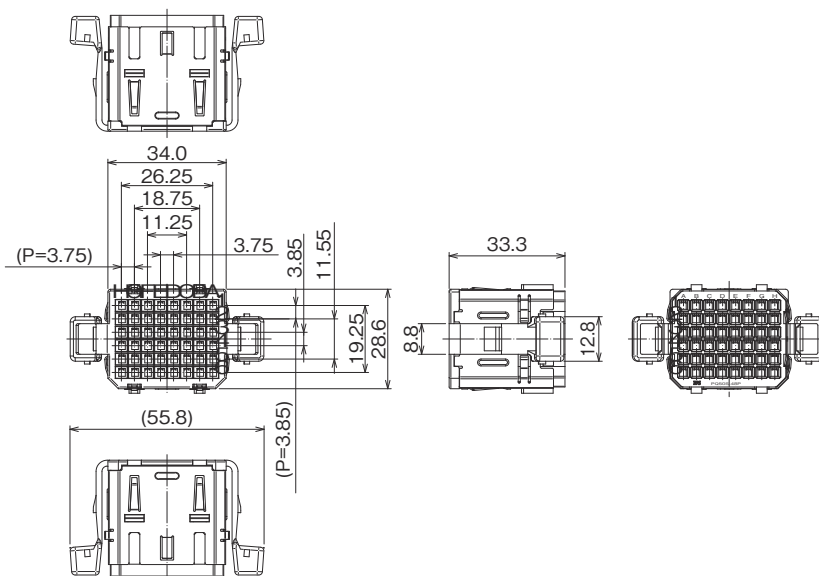

Part No.	HRS No.	Purchase Unit
PQ50S-48P	CL0236-2023-3-00	60pcs per box
PQ50S-48P(01)	CL0236-2023-3-01	1pc per box

●Plug Cover Case

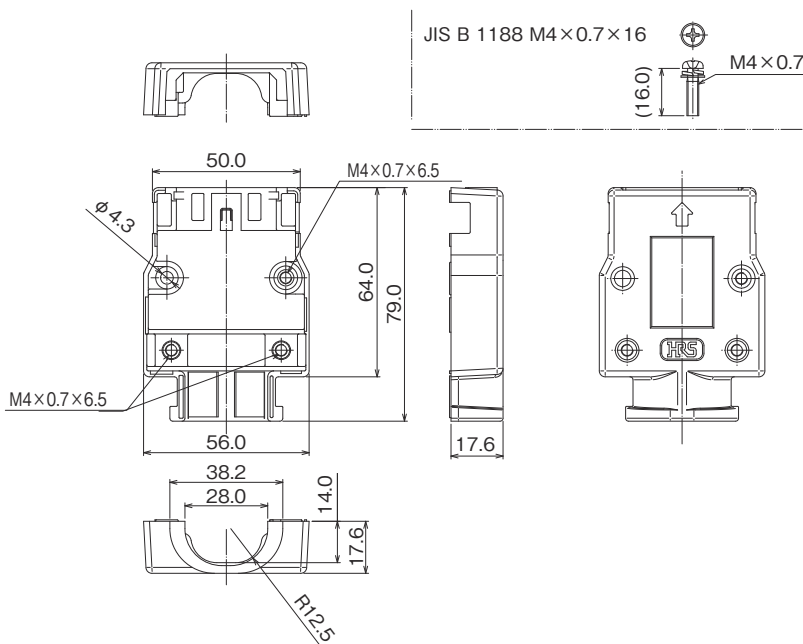

Part No.	HRS No.	Purchase Unit
PQ50S-48P-PCMA	CL0236-2129-0-00	60pcs per box
PQ50S-48P-PCMA(01)	CL0236-2129-0-01	1pc per box

PQ50S-48pos. Type

● Right Angle Plug Cover Case

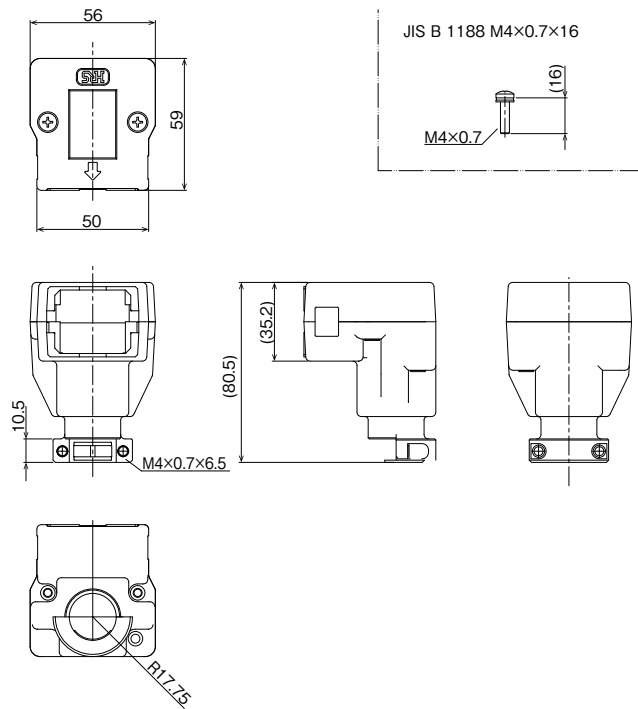

Part No.	HRS No.	Purchase Unit
PQ50S-48P-PCLMA	CL0236-2131-0-00	12pcs per box

Cable Clamp

PQ50S-48pos. Type

For Right Angle Plug Cover Case

● Cable Clamp (φ17.5)

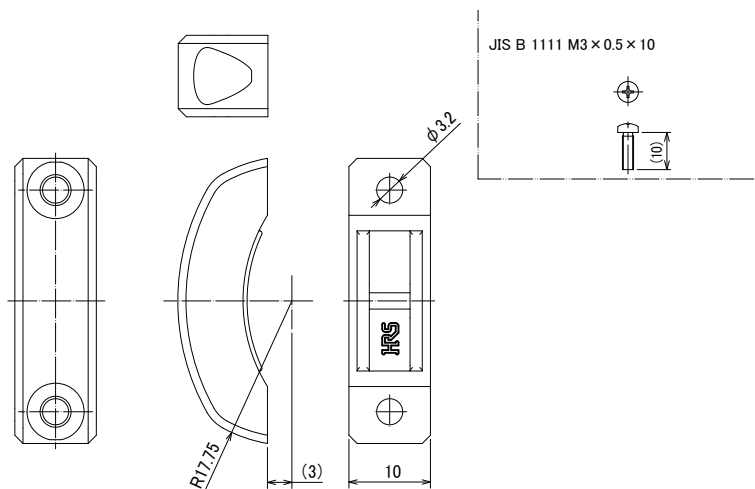

Part No.	HRS No.	Purchase Unit
PQ-CML(17.5)	CL0236-2079-8-00	12pcs per bag

Panel Mount Receptacle

PQ50S-48pos. Type

●Crimp Case (12.5A/pin for Female Contact)

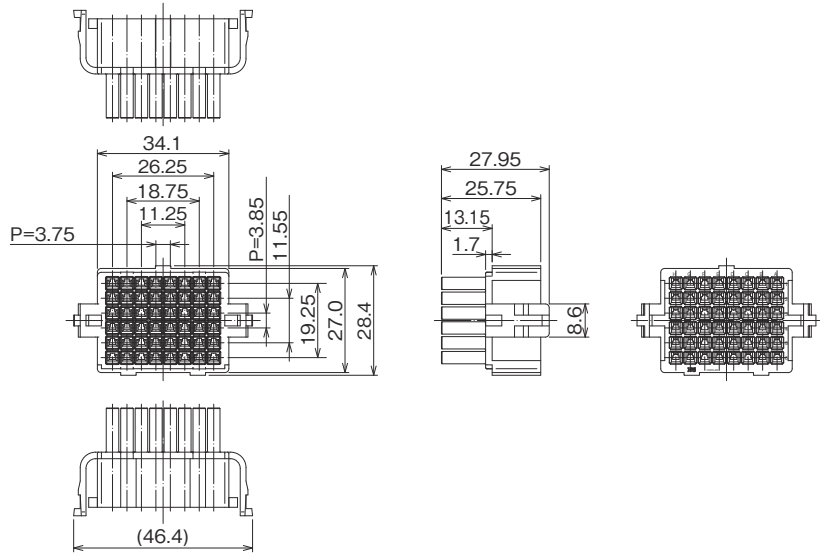

Part No.	HRS No.	Purchase Unit
PQ50S-48S	CL0236-2024-6-00	60pcs per box
PQ50S-48S(01)	CL0236-2024-6-01	1pc per box

●Panel Shell

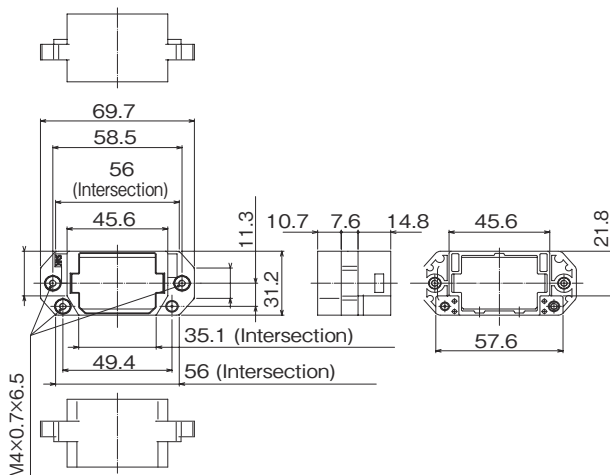

Panel Mounting Dimensions

Recommended panel dimensions for attaching panel shell from panel's front side.

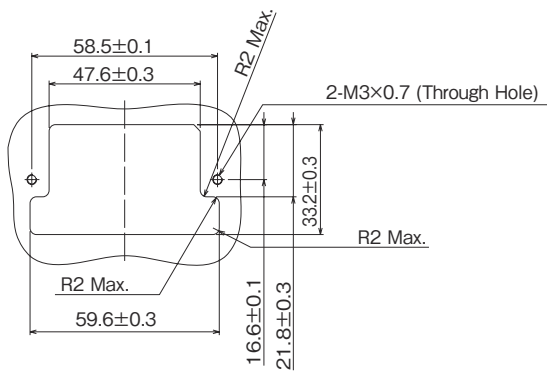

Recommended panel dimensions for attaching panel shell from panel's back side.

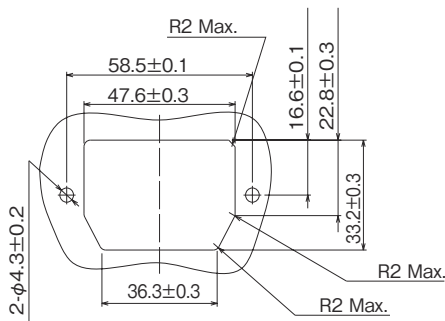

Part No.	HRS No.	Purchase Unit
PQ50S-48S-FLMA	CL0236-2130-0-00	60pcs per box
PQ50S-48S-FLMA(01)	CL0236-2130-0-01	1pc per box

Clamp Metal

PQ50/PQ50S Series

● Clamp Metal for $\phi 15.0\text{mm}$ Cable Type

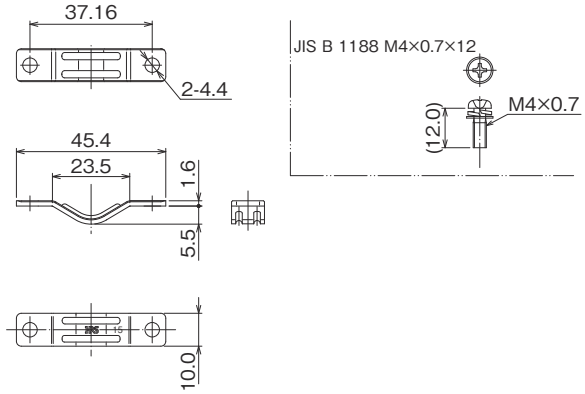

Part No.	HRS No.	Purchase Unit
PQ-CM(15.0)	CL0236-2005-1-00	60pcs per bag
PQ-CM(15.0)(01)	CL0236-2005-1-01	1pc per box

● Clamp Metal for $\phi 22.0\text{mm}$ Cable Type

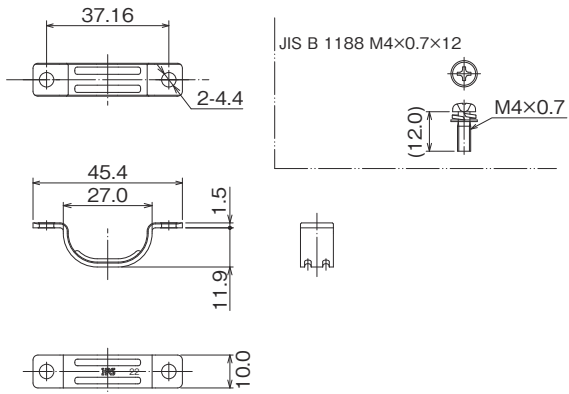

Part No.	HRS No.	Purchase Unit
PQ-CM(22.0)	CL0236-2013-0-00	50pcs per bag
PQ-CM(22.0)(01)	CL0236-2013-0-01	1pc per box

Cable Plug

PQ50W Series

●Crimp Case (12.5A/pin for Male Contact)

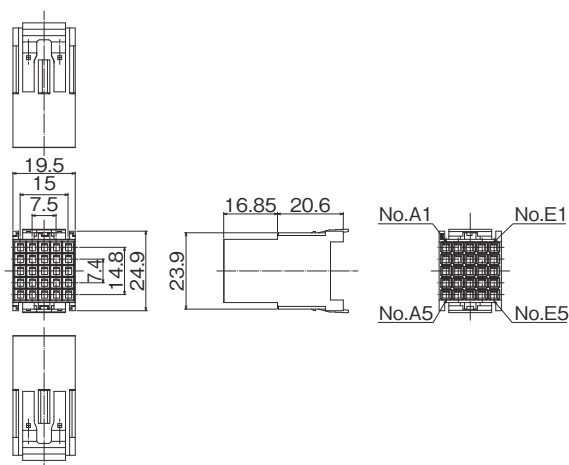

Part No.	HRS No.	Purchase Unit
PQ50WS-25P-UNIT	CL0236-2021-8-00	50pcs per box

●Crimp Case (12.5A/pin for Female Contact)

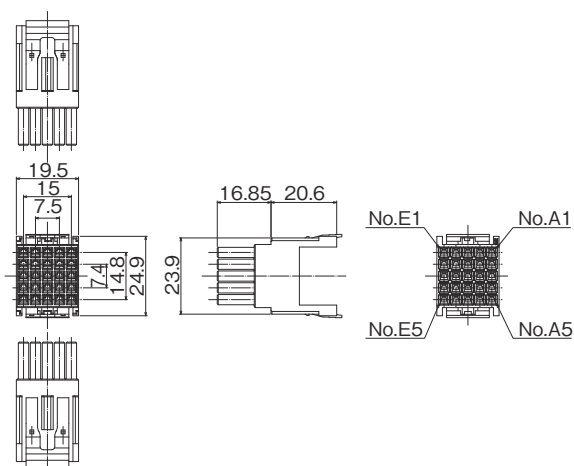

Part No.	HRS No.	Purchase Unit
PQ50WS-25S-UNIT	CL0236-2022-0-00	50pcs per box

Panel Mount Receptacle

PQ50W Series

● Panel Shell

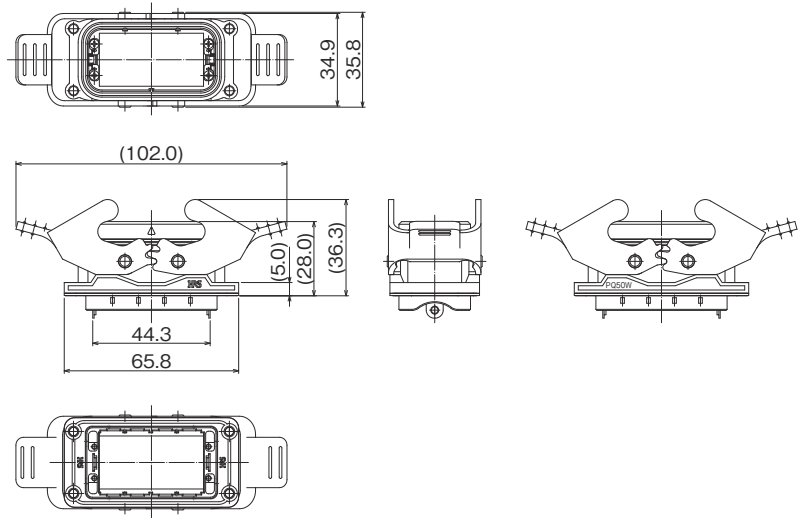

Panel Mounting Dimensions

Panel dimensions for attaching panel shell from panel's front side.

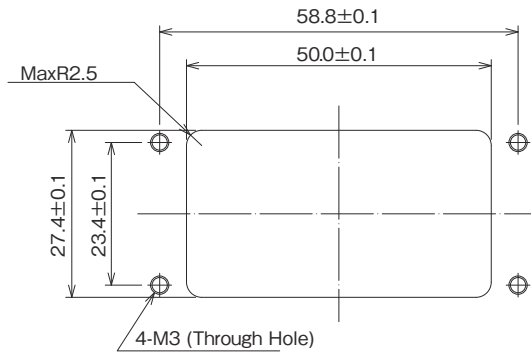

Part No.	HRS No.	Purchase Unit
PQ50W-50-FLA	CL0236-2132-0-00	20pcs per box

Cable Plug

PQ50W Series

●Cover Case

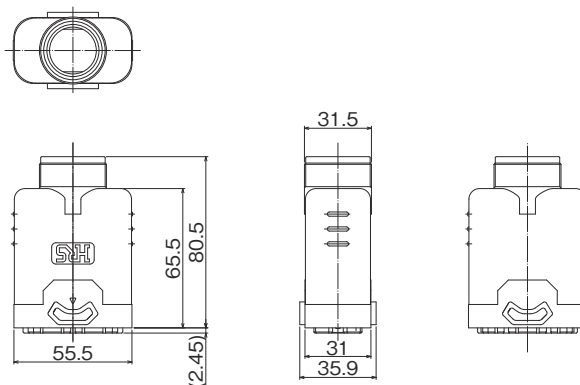

Part No.	HRS No.	Purchase Unit
PQ50W-50-PCA	CL0236-2133-0-00	10pcs per box

Cable Clamp

PQ50W Series

●Cable Clamp (φ17.5, φ15.0)

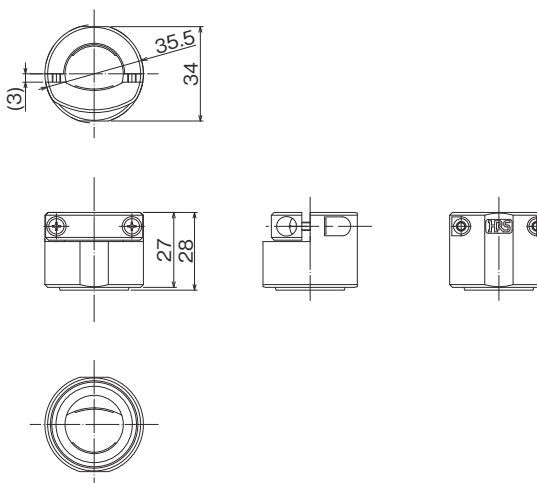

Part No.	HRS No.	Purchase Unit
PQW-CM(17.5)	CL0236-2019-6-00	25pcs per tray
PQW-CM(15.0)	CL0236-2104-0-00	

Crimp Contact

● Male Contact (19A/pin Type)

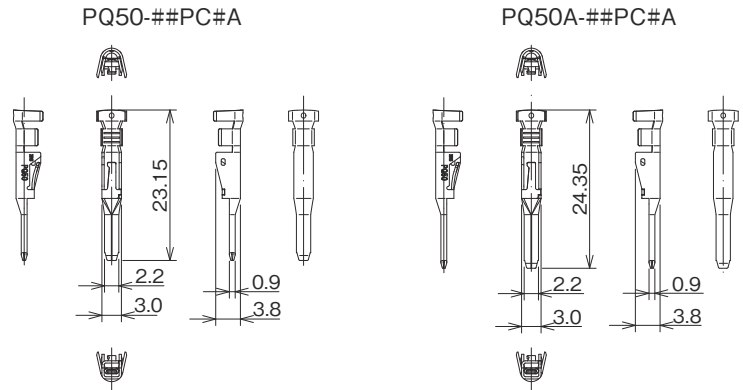

Part No.	HRS No.	Purchase Unit	Applicable Cables
PQ50-15PCFA (Note)	CL0236-2016-8-00	3,500pcs per reel	14 to 15 AWG insulator outer diameter Max. ϕ 3.3mm
PQ50A-15PCFA (Note)	CL0236-2073-1-00		14 to 15 AWG insulator outer diameter Max. ϕ 3.3mm
PQ50-1618PCFA	CL0236-2006-4-00		16 to 18 AWG insulator outer diameter Max. ϕ 3.3mm
PQ50A-1618PCFA	CL0236-2007-7-00		16 to 18 AWG insulator outer diameter Max. ϕ 3.3mm
PQ50-2022PCFA	CL0236-2031-1-00		20 to 22 AWG insulator outer diameter Max. ϕ 2.7mm
PQ50A-2022PCFA	CL0236-2032-4-00		20 to 22 AWG insulator outer diameter Max. ϕ 2.7mm
PQ50-15PCA	CL0236-2037-8-00	100pcs per bag	14 to 15 AWG insulator outer diameter Max. ϕ 3.3mm
PQ50A-15PCA	CL0236-2073-1-00		14 to 15 AWG insulator outer diameter Max. ϕ 3.3mm
PQ50-1618PCA	CL0236-2038-0-00		16 to 18 AWG insulator outer diameter Max. ϕ 3.3mm
PQ50A-1618PCA	CL0236-2040-2-00		16 to 18 AWG insulator outer diameter Max. ϕ 3.3mm
PQ50-2022PCA	CL0236-2039-3-00		20 to 22 AWG insulator outer diameter Max. ϕ 2.7mm
PQ50A-2022PCA	CL0236-2041-5-00		20 to 22 AWG insulator outer diameter Max. ϕ 2.7mm

Note: Please see ATAI-E2926 for details on UL1015, 14 AWG cable crimping.

●Female Contact (19A/pin) Type

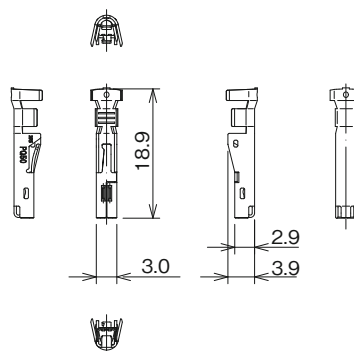

Part No.	HRS No.	Purchase Unit	Applicable Cables
PQ50-15SCFA (Note)	CL0236-2017-0-00	3,500pcs per reel	14 to 15 AWG insulator outer diameter Max. ϕ 3.3mm
PQ50-1618SCFA	CL0236-2008-0-00		16 to 18 AWG insulator outer diameter Max. ϕ 3.3mm
PQ50-2022SCFA	CL0236-2010-1-00		20 to 22 AWG insulator outer diameter Max. ϕ 2.7mm
PQ50-15SCA	CL0236-2043-0-00	100pcs per bag	14 to 15 AWG insulator outer diameter Max. ϕ 3.3mm
PQ50-1618SCA	CL0236-2044-3-00		16 to 18 AWG insulator outer diameter Max. ϕ 3.3mm
PQ50-2022SCA	CL0236-2045-6-00		20 to 22 AWG insulator outer diameter Max. ϕ 2.7mm

Note : Please see ATAI-E3038 for details on UL1015, 14 AWG cable crimping.

● Male Contact (12.5A/pin Type)

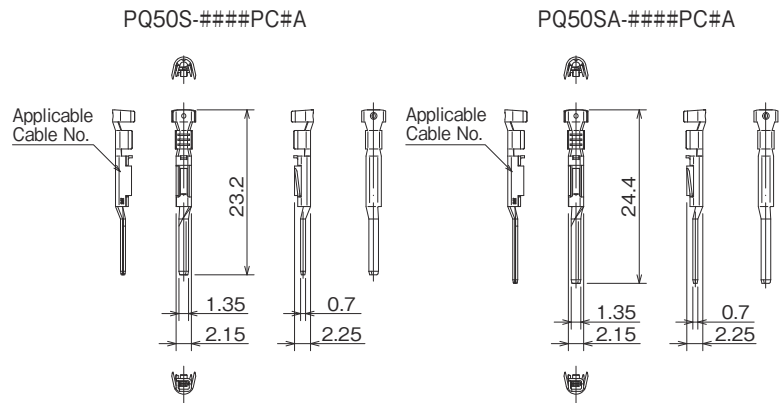

Part No.	HRS No.	Purchase Unit	Applicable Cables
PQ50S-1618PCFA	CL0236-2094-0-00	6,000pcs per reel	16 to 18 AWG insulator outer diameter Max. ϕ 2.25mm
PQ50S-1822PCFA	CL0236-2025-9-00		18 to 22 AWG insulator outer diameter Max. ϕ 2.25mm
PQ50SA-1822PCFA	CL0236-2029-0-00		18 to 22 AWG insulator outer diameter Max. ϕ 2.25mm
PQ50S-2428PCFA	CL0236-2027-4-00		24 to 28 AWG insulator outer diameter Max. ϕ 1.8mm
PQ50SA-2428PCFA	CL0236-2030-9-00		24 to 28 AWG insulator outer diameter Max. ϕ 1.8mm
PQ50S-1822PCA	CL0236-2046-9-00	100pcs per bag	18 to 22 AWG insulator outer diameter Max. ϕ 2.25mm
PQ50SA-1822PCA	CL0236-2048-4-00		18 to 22 AWG insulator outer diameter Max. ϕ 2.25mm
PQ50S-2428PCA	CL0236-2047-1-00		24 to 28 AWG insulator outer diameter Max. ϕ 1.8mm
PQ50SA-2428PCA	CL0236-2049-7-00		24 to 28 AWG insulator outer diameter Max. ϕ 1.8mm

● Female Contact (12.5A/pin Type)

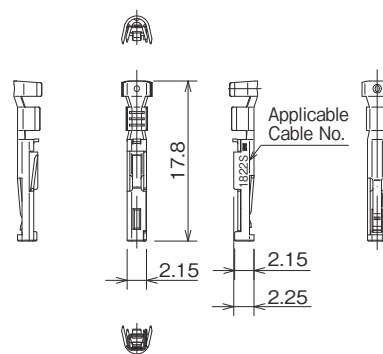

Part No.	HRS No.	Purchase Unit	Applicable Cables
PQ50S-1618SCFA	CL0236-2095-0-00	6,000pcs per reel	16 to 18 AWG insulator outer diameter Max. ϕ 2.25mm
PQ50S-1822SCFA	CL0236-2026-1-00		18 to 22 AWG insulator outer diameter Max. ϕ 2.25mm
PQ50S-2428SCFA	CL0236-2028-7-00		24 to 28 AWG insulator outer diameter Max. ϕ 1.8mm
PQ50S-1822SCA	CL0236-2050-6-00	100pcs per bag	18 to 22 AWG insulator outer diameter Max. ϕ 2.25mm
PQ50S-2428SCA	CL0236-2051-9-00		24 to 28 AWG insulator outer diameter Max. ϕ 1.8mm

Coding Key System

● For 19A/pin Type Crimp Case

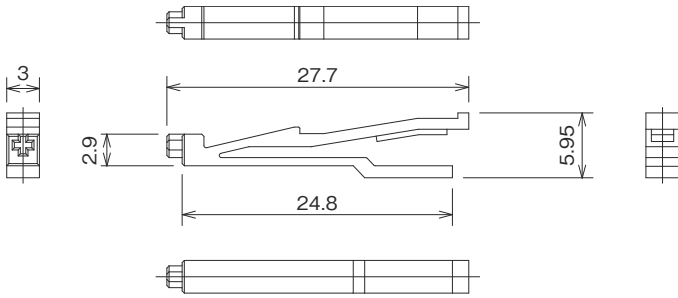

Part No.	HRS No.	Purchase Unit
PQ50-SC-KY	CL0236-2009-2-00	100pcs per bag

● For 12.5A/pin Type Crimp Case

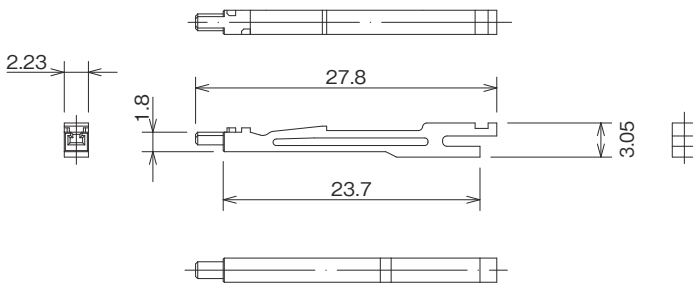

Part No.	HRS No.	Purchase Unit
PQ50S-SC-KY	CL0236-2033-7-00	100pcs per bag

Extraction Tool

● 19A/pin Type for Crimp Case

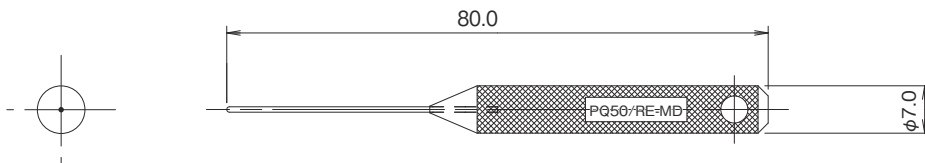

Part No.	HRS No.	Purchase Unit
PQ50/RE-MD	CL0902-2201-0-00	1pc per box

● 12.5A/pin Type for Crimp Case

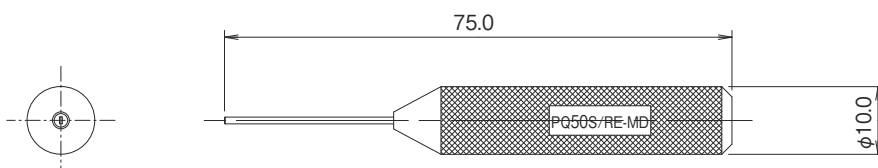

Part No.	HRS No.	Purchase Unit
PQ50S/RE-MD	CL0902-2202-2-00	1pc per box

Pin Push Inspection Tool

● 12.5A/pin Type for Crimp Case

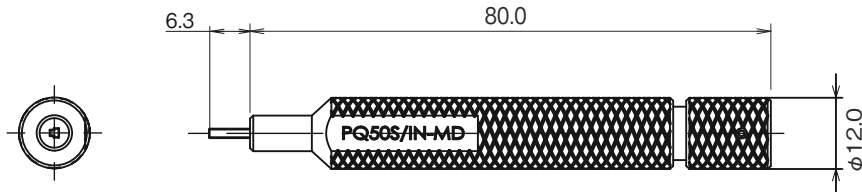

Part No.	HRS No.	Purchase Unit
PQ50S/IN-MD	CL0902-2538-0-00	1 pc per box

Note : Used to confirm whether the contact is securely mated to the housing when connecting.

Contact Crimping Tool

For details, refer to the crimping tool list in the PQ series product selection guide (ETAD-E3254-00) .

Automatic Crimping Machine/Applicator for Automatic Crimping Machine

Please contact a Hirose sales representative.

Manual Crimping Tool

Please purchase a compatible frame and tooth profile unit according to the cable you are using.

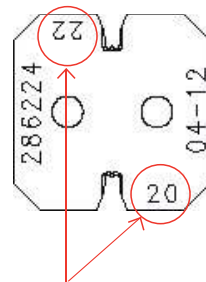
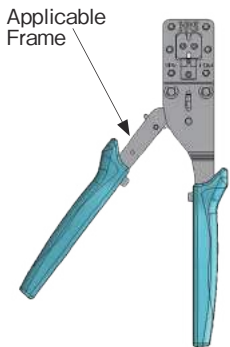

Switch wire crimper and insulation crimper die according to the wire size being used.

Part No.	HRS No.	Remarks
HT702	CL0250-1001-1-00	Frame only, tooth profile unit sold separately

About Guidelines

- Refer to the PQ series design and handling manual (ETAD-E3230-00) for product handling and precautions for equipment design.
- Please refer to the PQ series product selection guide (ETAD-E3254-00) if you are having trouble selecting a product.

While Taking into Consideration

Specifications mentioned in this catalog are reference values.

When considering to order or use this product, please review the Drawing and Product Specifications sheets.

Use an appropriate cable when using the connector in combination with cables.

If considering usage of a non-specified cable, please contact your sales representative.

If assembly process is done by jigs & tools which are not identified by Hirose, the warranty of the product may be affected.

If considering usage for below mentioned applications, please contact your sales representative.

In cases where the application will demand a high level of reliability, such as automotive, medical instruments, public infrastructure, aerospace/defense etc. Hirose must review before assurance of reliability can be given.

HIROSE**HIROSE ELECTRIC CO.,LTD.**2-6-3 Nakagawa Chuoh, Tsuzuki-Ku, Yokohama-Shi 224-8540, JAPAN
<https://www.hirose.com>