

PART NUMBER	REVISION	DESCRIPTION	FEED TYPE
2151971-2	D	FINE CRIMP HEIGHT ADJUST	PNEUMATIC
7-2151971-2	D	PNEUMATIC AND CRIMP TOOLING KIT	PNEUMATIC
7-2151971-7	A	CRIMP TOOLING KIT	-

ATLANTIC VERSION TERMINATOR INTERFACE ADAPTER

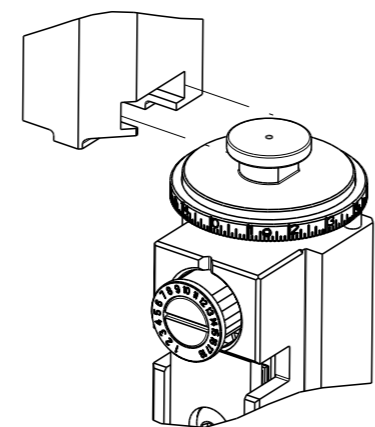

APPLICATOR DATA		
CRIMP	SIZE	TYPE
WIRE	3.45 mm [.136]	F
INSUL	4.32 mm [.170]	F

APPLICATOR INSTRUCTIONS
408-35042

TERMINAL DATA: TE TERMINAL		TE CRIMP SPECIFICATION	
TERMINAL NAME: ASSY, TERMINAL RING TONGUE			
WIRE STRIP LENGTH		INSULATION DIAMETER RANGE	
5.50-6.00 mm [.217-.236 IN]		Ø3.10-4.20 mm [.122-.165 IN]	
TERMINAL APPLICATION SPECIFICATION	114-37015		
TERMINALS APPLIED			
TE TERMINAL	TE TERMINAL	TE TERMINAL	TE TERMINAL
1599298-1	1599298-3	1599298-4	1599298-5

WIRE SIZE	CRIMP HEIGHT mm [INCH]	CRIMP HEIGHT REFERENCE SETTING
2.50mm2	2.57+/-0.05 [.101+/- .002]	5.7
2.00mm2	2.43+/-0.05 [.096+/- .002]	7.5
1.50mm2	2.33+/-0.05 [.092+/- .002]	8.3

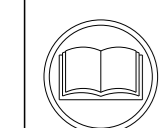

- RECOMMENDED SPARE PARTS
- REFER TO SUPPLIED INSTRUCTION SHEET FOR CLEANING, LUBRICATION AND STORAGE OF APPLICATOR.
- APPLY PART NUMBER 2-23419-6 LOCTITE TO THREADS OF ITEM 242. APPLY PART NUMBER 1-23419-5 LOCTITE TO THREADS OF ITEM 180.
- CRIMP HEIGHT REFERENCE SETTING WAS THE SETTING USED WHEN THE APPLICATOR WAS QUALIFIED AT THE FACTORY. ADJUSTMENT MAY BE NECESSARY WHEN RUNNING APPLICATOR IN THE FIELD.
- TERMINAL PITCH NOT COMPATIBLE WITH MECHANICAL FEED.
- 6. UNLESS SPECIFIED OTHERWISE TORQUE VALUES SHALL BE USED PER DOCUMENT, 101-35000.
- MAXIMUM CMA FOR 2.50mm2 IS 5000 CMA.

***WARNING**
ON INSTALLATION, SET WIRE DISC TO CRIMP HEIGHT REFERENCE SETTING FOR LARGEST WIRE SIZE. CRIMP HEIGHT REFERENCE SETTINGS GREATER THAN THE VALUE SHOWN MAY CAUSE DAMAGE TO THE CRIMP TOOLING. REFER TO THE INSTRUCTION SHEET FOR PROPER SETUP AND ADJUSTMENTS.

LOC	DIST	REVISIONS					
		P	LY#	DESCRIPTION	DATE	OWN	APVD
A	66	A		RELEASED	16AUG2013	LG	GB
		B		ECR-19-007040	03MAY2019	TB	CT
		C		ECR-19-008519	29MAY2019	MEH	GB
		D		ECR-21-003914	06APR2021	JWC	RR

-	2	2	2168083-1	SCR, SKT HD CAP, RoHS, M3 X 8.0	269
-	1	1	1-690438-0	FRONT STRIP GUIDE	268
-	2	2	22283-1	SPRING, COMPRESSION	267
-	2	2	2-18032-5	SCR, SET, FLT PNT, M5 X 20.0	266
-	1	1	980371-4	SCR, SKT HD SHLDR 5.0 DIA X 6.0	265
-	1	1	356835-1	LEVER, DRAG RELEASE	264
-	1	1	240792-1	DRAG, TERMINAL	263
-	2	2	2168083-1	SCR, SKT HD CAP, RoHS, M3 X 8.0	262
-	1	1	1633782-8	FENCE	261
-	1	1	2119641-1	FEED CAM, AIR FEED	248
-	1	1	2119082-4	CAM, SNAIL, INSULATION ADJUSTMENT	244
-	1	1	2079764-1	WASHER, WAVE SPRING, CREST-TO-CREST	243
-	1	1	2119083-1	RETAINER, INSULATION DIAL	242
-	1	1	7-18023-7	SCR, SKT HD CAP M3 X 4.0	241
-	1	1	2844940-2	AIR FEED MODULE	238
-	1	1	2-1752354-0	STANDOFF, HOLD-DOWN	180
-	1	1	993111-1	PIN, SLOTTED SPRING 3.0 X 20.0	177
-	1	1	8-22280-7	SPRING, COMPRESSION	176
-	1	1	1752353-2	GUIDE PIN, HOLDDOWN	175
-	1	1	1901680-2	GUIDE PIN, HOLDDOWN	174
-	REF	REF	994970-2	COUNTER, MAGNETIC	164
-	1	1	2844908-1	SCREW, LOCKING	99
-	1	1	2844907-1	POST, LOCKING	98
-	1	1	455888-5	SPACER, CRIMPER	82
-	1	1	1-22278-0	SPRING, COMPRESSION	77
-	1	1	854769-4	HOLDER, INS	74
-	1	1	1803607-3	DOCUMENTATION PACKAGE	71
-	1	1	2119791-5	DEPRESSOR, WIRE	70
-	1	1	2119740-1	TAG, IDENTIFICATION	67
-	2	2	2168078-1	SCREW, DRIVE, RH, RoHS, 2 x .188	66
-	1	1	2168083-2	SCR, SKT HD CAP, RoHS, M4 X 8.0	60
-	1	1	5-18022-5	SCR, HEX HD CAP, M4 X 6.0	59
-	1	1	21028-2	PIN, SLOTTED SPRING .062 X .250	58
-	1	1	1-1338683-1	FEED PAWL	56
-	4	4	2168083-3	SCR, SKT HD CAP, RoHS, M4 X 12.0	54
-	1	1	1-5018030-0	NUT, HEX, REG, RoHS, M3.5	52
-	1	1	1901681-2	HOLDDOWN, TERMINAL	51
-	1	1	18023-9	SCR, SKT HD CAP M4 X 6.0	49
-	1	1	1803583-9	APPLICATOR BASIC ASSEMBLY, SF	46
-	1	1	1803515-3	RAM ASSEMBLY, SF ATLANTIC	44
-	1	1	1803602-1	SCR, BHSC, RoHS (M8 X 25)	41
-	1	1	1752356-6	SUPPORT, TERMINAL	34
-	2	2	1-2079383-3	SCR, BHSC, RoHS (M4 X 25)	33
-	2	2	4-2844962-2	SPACER, CYLINDRICAL, STRIP GUIDE	30
-	1	1	2844992-3	ASSEMBLY, STRIP GUIDE	29
-	1	1	455888-3	SPACER, CRIMPER	28
-	1	1	1320928-8	STRIP GUIDE	24
-	1	1	2168083-2	SCR, SKT HD CAP, RoHS, M4 X 8.0	21
-	2	2	1-18028-2	WASHER, FLAT, REG M4	20
-	1	1	2119533-1	STRIPPER, SIDE FEED	19
-	1	1	2119806-1	INSERT, SHEAR	13
-	1	1	3-22280-3	SPRING, COMPRESSION	12
-	1	1	1-356885-3	STOP, SHEAR	11
-	1	1	2119805-1	SHEAR HOLDER, FRONT	10
-	1	1	454276-5	FLOATING SHEAR, FRONT	9
-	1	2	1-1803057-4	ANVIL, COMBINATION	8
-	-	-	-	-	7
-	-	-	-	-	6
-	1	1	2119780-9	DEPRESSOR, SHEAR	5
-	1	1	2-238011-1	BLOCK, CRIMPER SPACER	4
-	1	2	1-1633962-7	CRIMPER, INSULATION F PREMIUM	3
-	1	1	455888-1	SPACER, CRIMPER	2
-	1	2	1-1633730-6	CRIMPER, WIRE	1
-	77	72	-2	PART NO	ITEM NO

ATLANTIC VERSION
Shown on sheets 1 of 4 & 2 of 4
(Pacific version shown on sheets 3 of 4 & 4 of 4)

DIMENSIONS:		TOLERANCES UNLESS OTHERWISE SPECIFIED:		APPROVED:		NAME:	
mm	0 PLC ±	1 PLC ±	2 PLC ±	3 PLC ±	4 PLC ±	ANGLES ±	FINISH
MATERIAL		WEIGHT		SCALE		SHEET	
-		-		1:2		1 OF 4	

Customer Accessible Production Drawing

LOC		DIST		REVISIONS			
A	66	P	LYR	DESCRIPTION	DATE	OWN	APVD
		-		SEE SHEET 1	-	-	-

FEED TYPE

PNEUMATIC

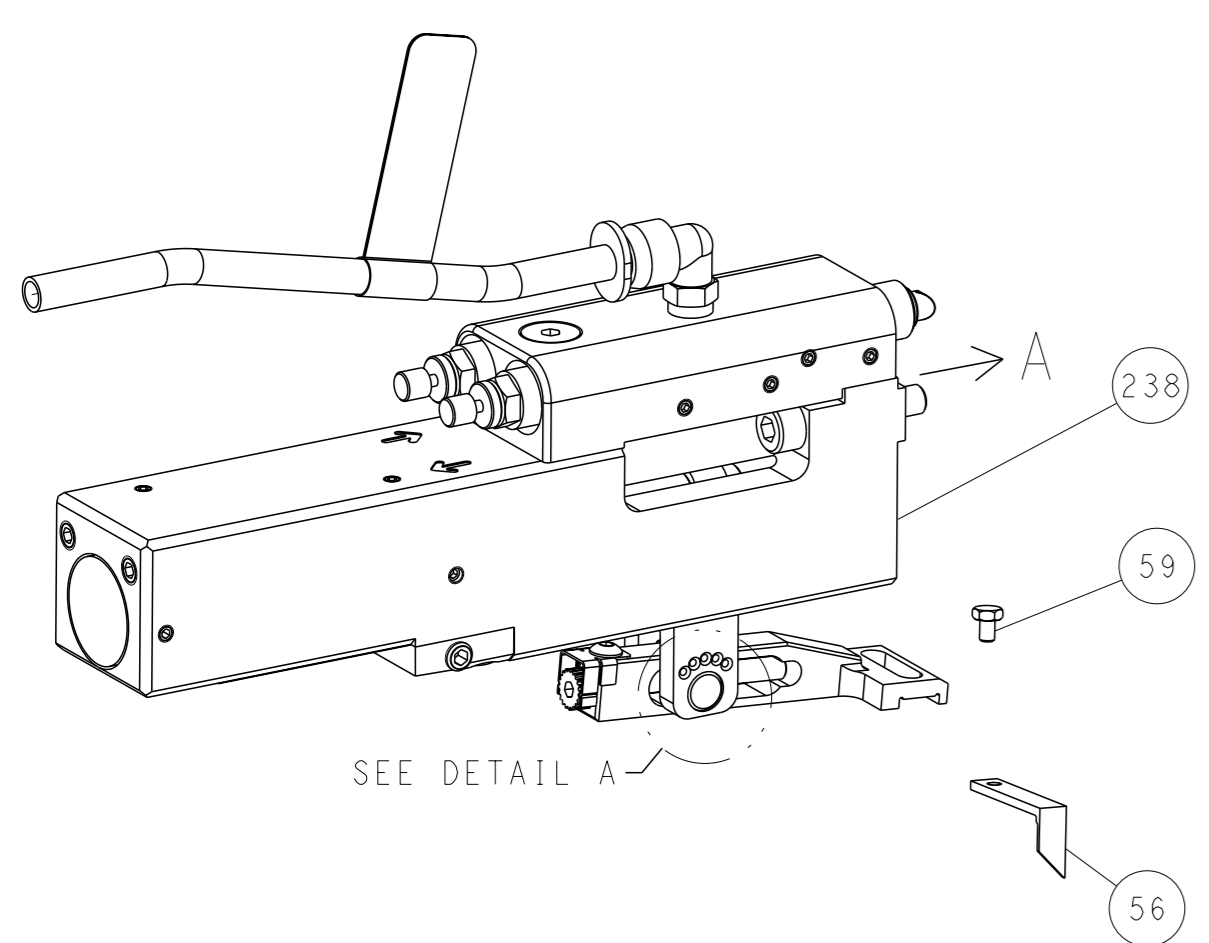

FEED SPRING SETTING POSITION
(SHOWN FROM REAR SIDE)

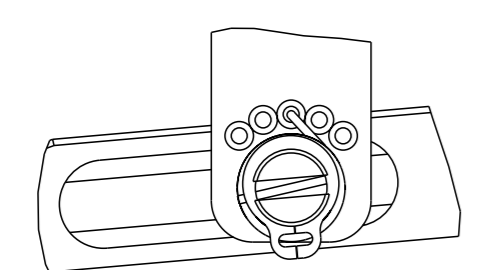

DETAIL A

CAM POSITION

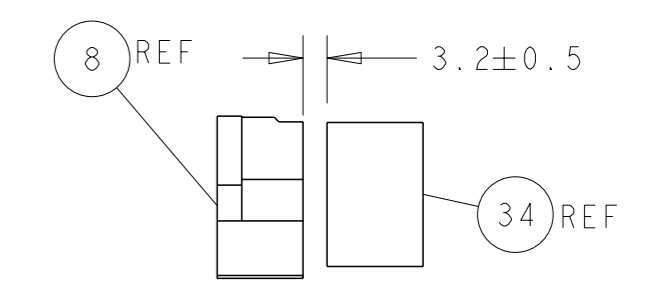
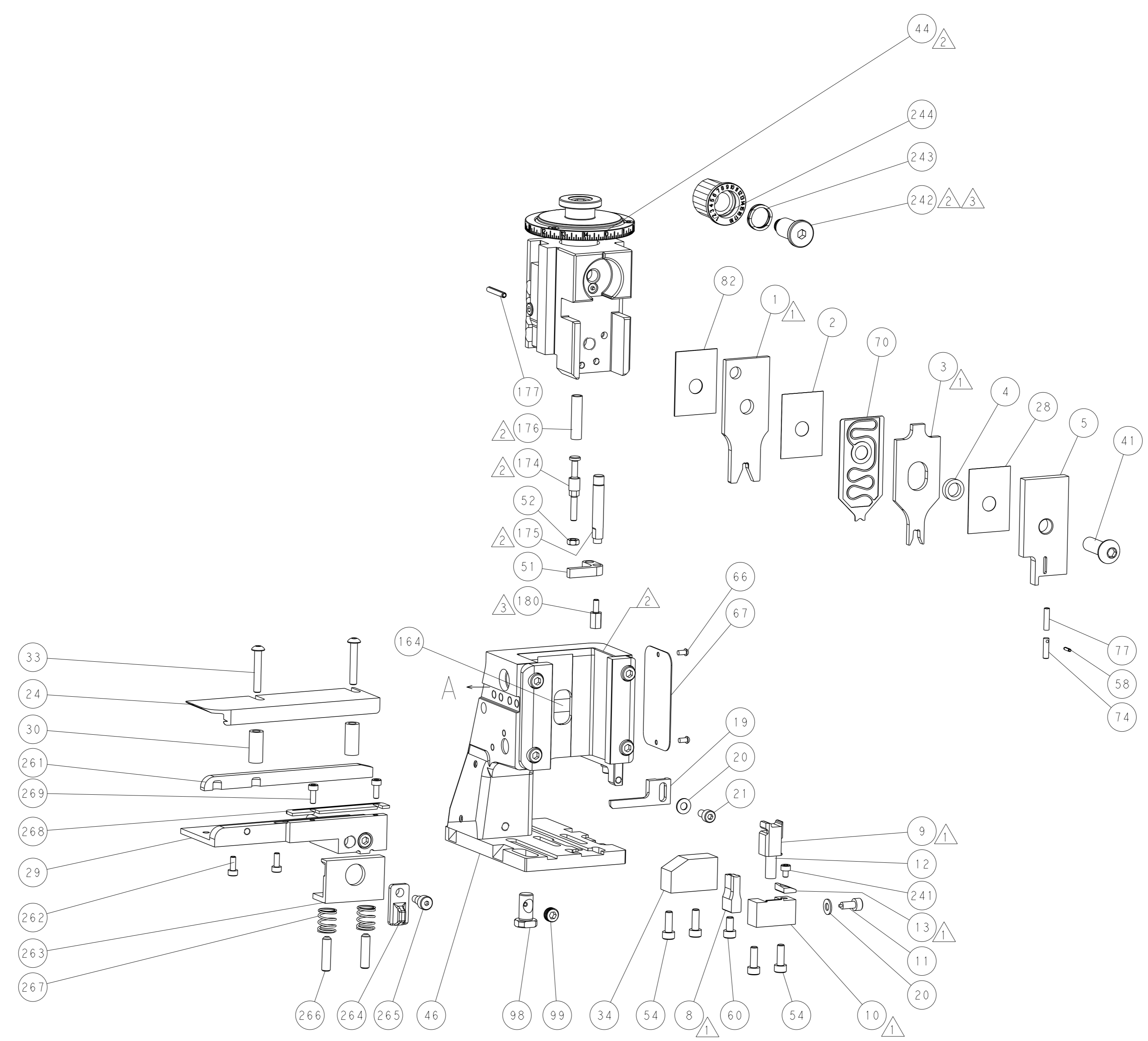
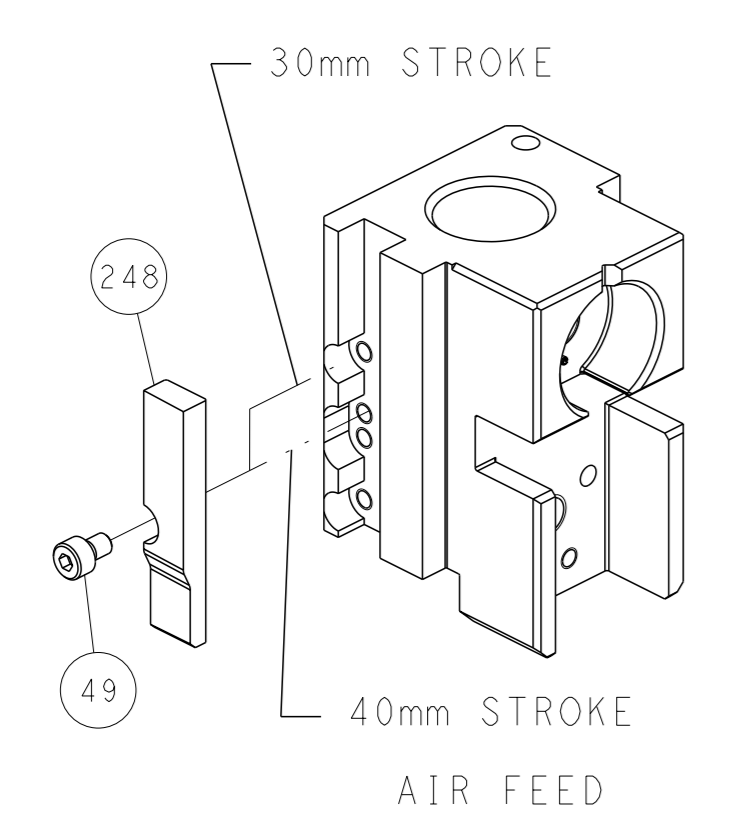

TERMINAL SUPPORT LOCATION

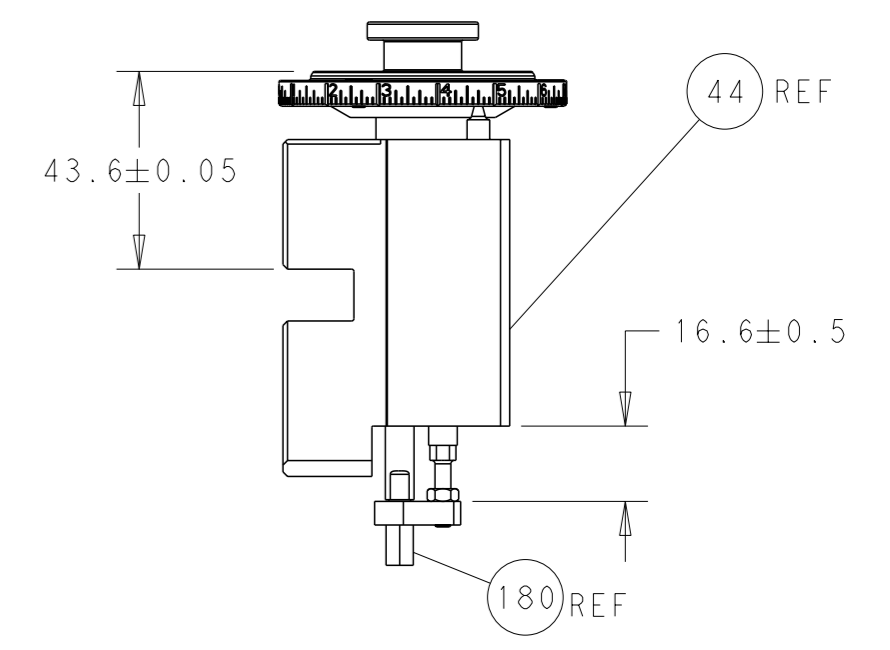

RAM AND HOLDDOWN SET-UP

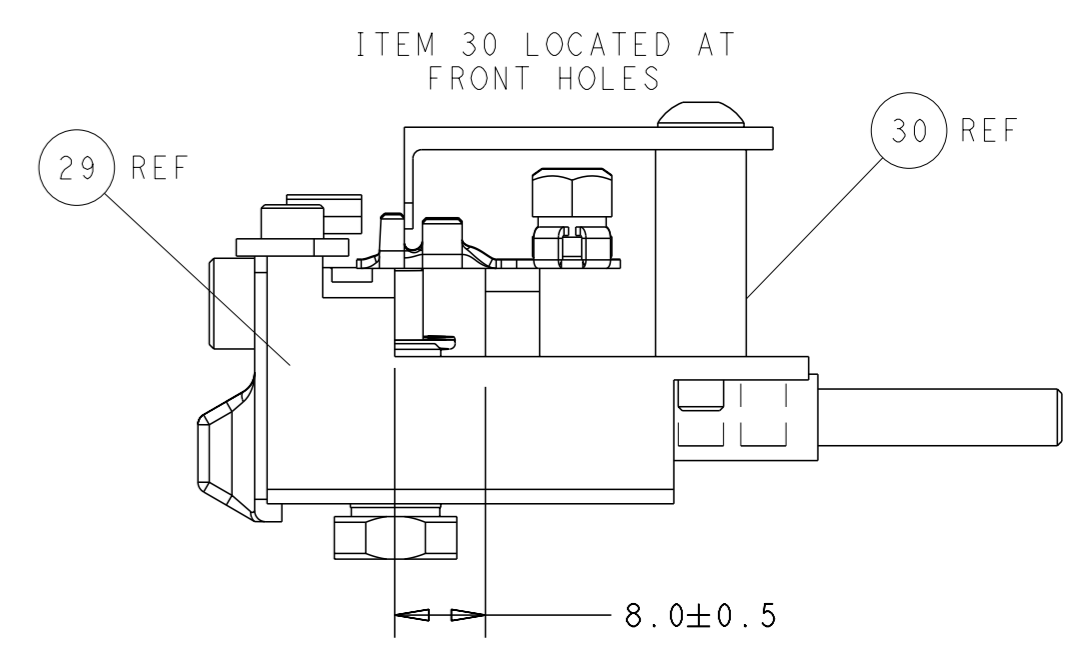

FEED TRACK POSITION
GUIDE BY INSULATION BARREL

ATLANTIC VERSION
 Shown on sheets 1 of 4 & 2 of 4
 (Pacific version shown on sheets 3 of 4 & 4 of 4)

<small>THIS DRAWING IS A CONTROLLED DOCUMENT FOR TYCO ELECTRONICS CORPORATION IT IS SUBJECT TO CHANGE AND THE CONTROL AND ENGINEERING ORGANIZATION SHOULD BE CONTACTED FOR THE LATEST REVISION.</small>		DWN C. CHEN 09JUN2013 CHK U. GUO 09JUN2013 APVD J. CRUZ 09JUN2013	NAME Ocean Side Feed Applicator SIZE A1 CAGE CODE 00779 DRAWING NO. 2151971 SCALE 1:2	RESTRICTED TO SHEET 2 OF 4 REV D
DIMENSIONS: mm TOLERANCES UNLESS OTHERWISE SPECIFIED: 0 PLC ± 1 PLC ± 2 PLC ± 3 PLC ± 4 PLC ± ANGLES FINISH ±	WEIGHT Customer Accessible Production Drawing	TE Connectivity Harrisburg, PA 17105-3608		

PART NUMBER	REVISION	DESCRIPTION	FEED TYPE
2-2151971-2	D	FINE CRIMP HEIGHT ADJUST	PNEUMATIC
7-2151971-7	A	CRIMP TOOLING KIT	-

PACIFIC VERSION TERMINATOR
INTERFACE ADAPTER

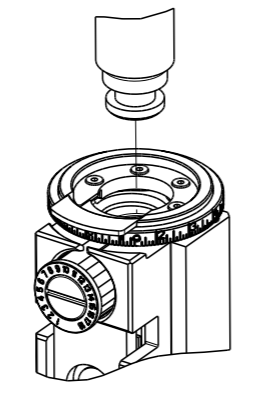

APPLICATOR DATA		
CRIMP	SIZE	TYPE
WIRE	3.45 mm [.136]	F
INSUL	4.32 mm [.170]	F
APPLICATOR INSTRUCTIONS 408-35042		

TERMINAL DATA: TE TERMINAL		TE CRIMP SPECIFICATION	
TERMINAL NAME: ASSY, TERMINAL RING TONGUE			
WIRE STRIP LENGTH		INSULATION DIAMETER RANGE	
5.50-6.00 mm [.217-.236 IN]		∅3.10-4.20 mm [.122-.165 IN]	
TERMINAL APPLICATION SPECIFICATION	114-37015		
TERMINALS APPLIED			
TE TERMINAL	TE TERMINAL	TE TERMINAL	TE TERMINAL
1599298-1	1599298-3	1599298-4	1599298-5

WIRE SIZE	CRIMP HEIGHT mm [INCH]	CRIMP HEIGHT REFERENCE SETTING
2.50mm2	2.57+/-0.05 [.101+/- .002]	5.7
2.00mm2	2.43+/-0.05 [.096+/- .002]	7.5
1.50mm2	2.33+/-0.05 [.092+/- .002]	8.3



- RECOMMENDED SPARE PARTS
- REFER TO SUPPLIED INSTRUCTION SHEET FOR CLEANING, LUBRICATION AND STORAGE OF APPLICATOR.
- APPLY PART NUMBER 2-23419-6 LOCTITE TO THREADS OF ITEM 242. APPLY PART NUMBER 1-23419-5 LOCTITE TO THREADS OF ITEM 180.
- CRIMP HEIGHT REFERENCE SETTING WAS THE SETTING USED WHEN THE APPLICATOR WAS QUALIFIED AT THE FACTORY. ADJUSTMENT MAY BE NECESSARY WHEN RUNNING APPLICATOR IN THE FIELD.
- TERMINAL PITCH NOT COMPATIBLE WITH MECHANICAL FEED.
- 6. UNLESS SPECIFIED OTHERWISE TORQUE VALUES SHALL BE USED PER DOCUMENT, 101-35000.
- MAXIMUM CMA FOR 2.50mm2 IS 5000 CMA.

***WARNING**
ON INSTALLATION, SET WIRE DISC TO CRIMP HEIGHT REFERENCE SETTING FOR LARGEST WIRE SIZE. CRIMP HEIGHT REFERENCE SETTINGS GREATER THAN THE VALUE SHOWN MAY CAUSE DAMAGE TO THE CRIMP TOOLING. REFER TO THE INSTRUCTION SHEET FOR PROPER SETUP AND ADJUSTMENTS.

LOC	DIST	REVISIONS					
A	66	P	LYR	DESCRIPTION	DATE	OWN	APVD
		-		SEE SHEET 1			

-	2	2168083-1	SCR, SKT HD CAP, RoHS, M3 X 8.0	269
-	1	1-690438-0	FRONT STRIP GUIDE	268
-	2	22283-1	SPRING, COMPRESSION	267
-	2	2-18032-5	SCR, SET, FLT PNT, M5 X 20.0	266
-	1	980371-4	SCR, SKT HD SHLDR 5.0 DIA X 6.0	265
-	1	356835-1	LEVER, DRAG RELEASE	264
-	1	240792-1	DRAG, TERMINAL	263
-	2	2168083-1	SCR, SKT HD CAP, RoHS, M3 X 8.0	262
-	1	1633782-8	FENCE	261
-	1	2119082-4	CAM, SNAIL, INSULATION ADJUSTMENT	244
-	1	2079764-1	WASHER, WAVE SPRING, CREST-TO-CREST	243
-	1	2119083-1	RETAINER, INSULATION DIAL	242
-	1	7-18023-7	SCR, SKT HD CAP M3 X 4.0	241
-	1	2844940-2	AIR FEED MODULE	238
-	1	2-1752354-0	STANDOFF,HOLD-DOWN	180
-	1	993111-1	PIN, SLOTTED SPRING 3.0 X 20.0	177
-	1	8-22280-7	SPRING, COMPRESSION	176
-	1	1752353-2	GUIDE PIN,HOLDDOWN	175
-	1	1901680-2	GUIDE PIN,HOLDDOWN	174
-	REF	994970-2	COUNTER, MAGNETIC	164
-	1	2119641-2	FEED CAM, AIR FEED	151
-	1	2168083-8	SCR, SKT HD CAP, RoHS, M4 X 16	144
-	4	2168083-9	SCR, SKT HD CAP, RoHS, M4 X 20	143
-	1	1-1803583-0	APPLICATOR BASIC ASSEMBLY, SF	141
-	1	1803516-1	RAM ASSEMBLY, SF PACIFIC	140
-	1	2844908-1	SCREW, LOCKING	99
-	1	2844907-1	POST, LOCKING	98
-	1	455888-5	SPACER, CRIMPER	82
-	1	1-22278-0	SPRING, COMPRESSION	77
-	1	854769-4	HOLDER, INS	74
-	1	1803607-3	DOCUMENTATION PACKAGE	71
-	1	2119791-5	DEPRESSOR, WIRE	70
-	1	2119740-1	TAG,IDENTIFICATION	67
-	2	2168078-1	SCREW, DRIVE, RH, RoHS, 2 x .188	66
-	1	5-18022-5	SCR, HEX HD CAP, M4 X 6.0	59
-	1	21028-2	PIN, SLOTTED SPRING .062 X .250	58
-	1	1-1338683-1	FEED PAWL	56
-	1	1-5018030-0	NUT, HEX, REG, RoHS, M3.5	52
-	1	1901681-2	HOLDDOWN, TERMINAL	51
-	1	18023-9	SCR, SKT HD CAP M4 X 6.0	49
-	1	1803602-1	SCR, BHSC, RoHS (M8 X 25)	41
-	1	1752356-6	SUPPORT, TERMINAL	34
-	2	1-2079383-3	SCR, BHSC, RoHS (M4 X 25)	33
-	2	4-2844962-2	SPACER, CYLINDRICAL, STRIP GUIDE	30
-	1	2844992-3	ASSEMBLY, STRIP GUIDE	29
-	1	455888-3	SPACER, CRIMPER	28
-	1	1320928-8	STRIP GUIDE	24
-	1	2168083-2	SCR, SKT HD CAP, RoHS, M4 X 8.0	21
-	2	1-18028-2	WASHER, FLAT, REG M4	20
-	1	2119533-1	STRIPPER, SIDE FEED	19
-	1	2119806-1	INSERT, SHEAR	13
-	1	3-22280-3	SPRING, COMPRESSION	12
-	1	1-356885-3	STOP, SHEAR	11
-	1	2119805-1	SHEAR HOLDER, FRONT	10
-	1	454276-5	FLOATING SHEAR, FRONT	9
-	1	1-1803057-4	ANVIL, COMBINATION	8
-	-	-	-	7
-	-	-	-	6
-	1	2119780-9	DEPRESSOR, SHEAR	5
-	1	2-238011-1	BLOCK, CRIMPER SPACER	4
-	1	3-1633962-7	CRIMPER, INSULATION F PREMIUM	3
-	1	455888-1	SPACER, CRIMPER	2
-	1	4-1633730-6	CRIMPER, WIRE	1
-	77	-22	PART NO	ITEM NO

PACIFIC VERSION
Shown on sheets 3 of 4 & 4 of 4
(Atlantic version shown on sheets 1 of 4 & 2 of 4)

<small>THE DRAWING IS A CONTROLLED DOCUMENT FOR THE ELECTRONICS CORPORATION. IT IS SUBJECT TO CHANGE AND THE CONTROLLER'S IDENTIFICATION SHOULD BE CONTACTED FOR THE LATEST REVISION.</small>		OWN: C. CHEN 09JUN2013 CHK: U. GUO 09JUN2013 APVD: J. CRUZ 09JUN2013	TE Connectivity Harrisburg, PA 17105-3608
DIMENSIONS: mm 0 PLC ± 1 PLC ± 2 PLC ± 3 PLC ± 4 PLC ± ANGLES FINISH ±	TOLERANCES UNLESS OTHERWISE SPECIFIED: ± ± ± ± ±	NAME: Ocean Side Feed Applicator SIZE: A1 CAGE CODE: 00779 DRAWING NO: 2151971 RESTRICTED TO: -	SCALE: 1:2 SHEET: 3 of 4 REV: D
MATERIAL: -		WEIGHT: -	Customer Accessible Production Drawing

LOC	DIST	REVISIONS			
A	66	REV	DATE	OWN	APVD
		-	SEE SHEET 1	-	-

FEED TYPE

PNEUMATIC

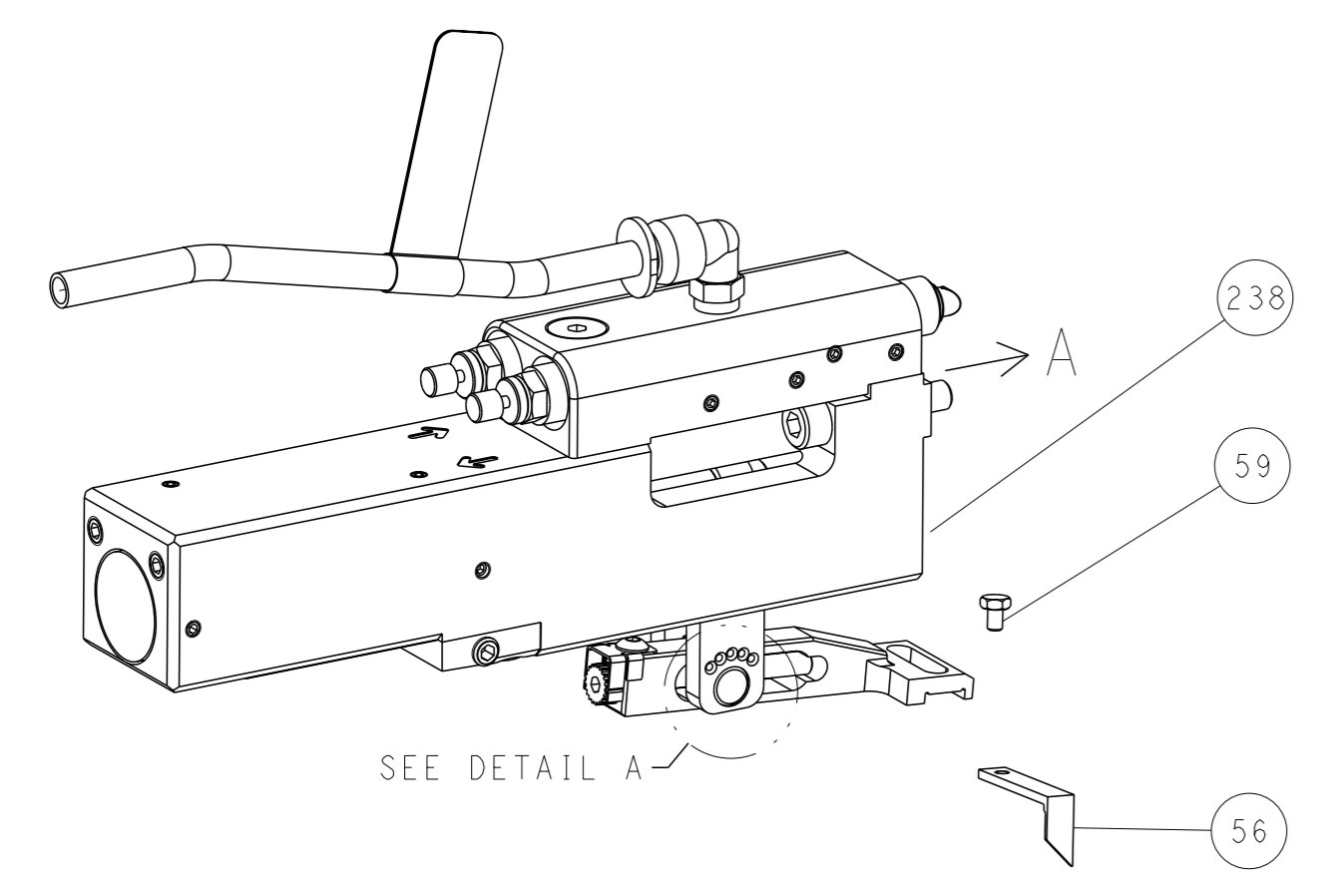

FEED SPRING SETTING POSITION (SHOWN FROM REAR SIDE)

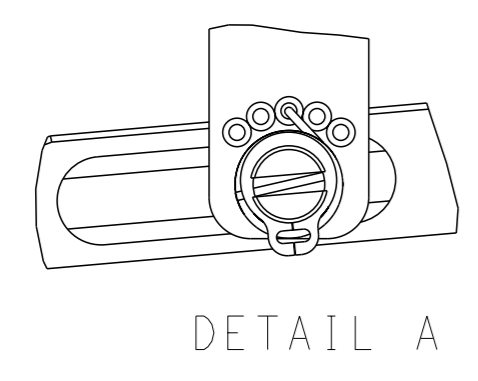

CAM POSITION

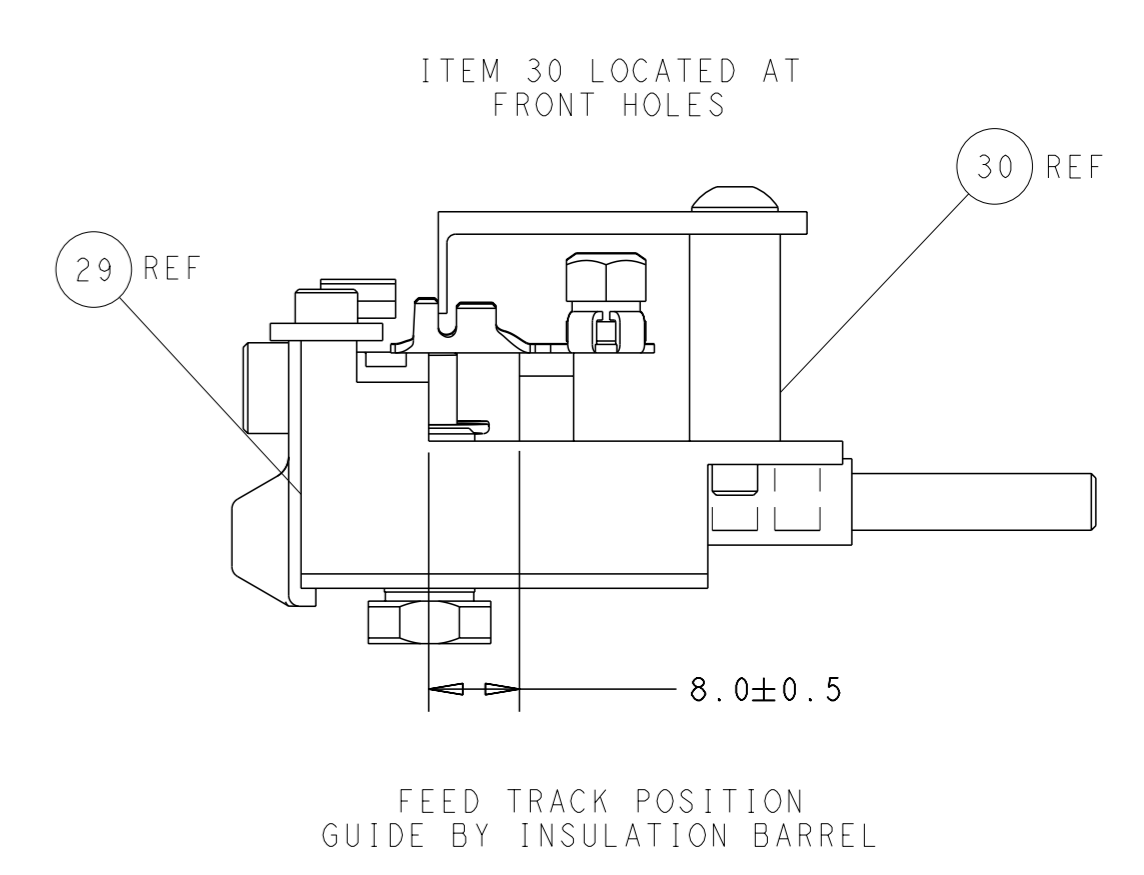
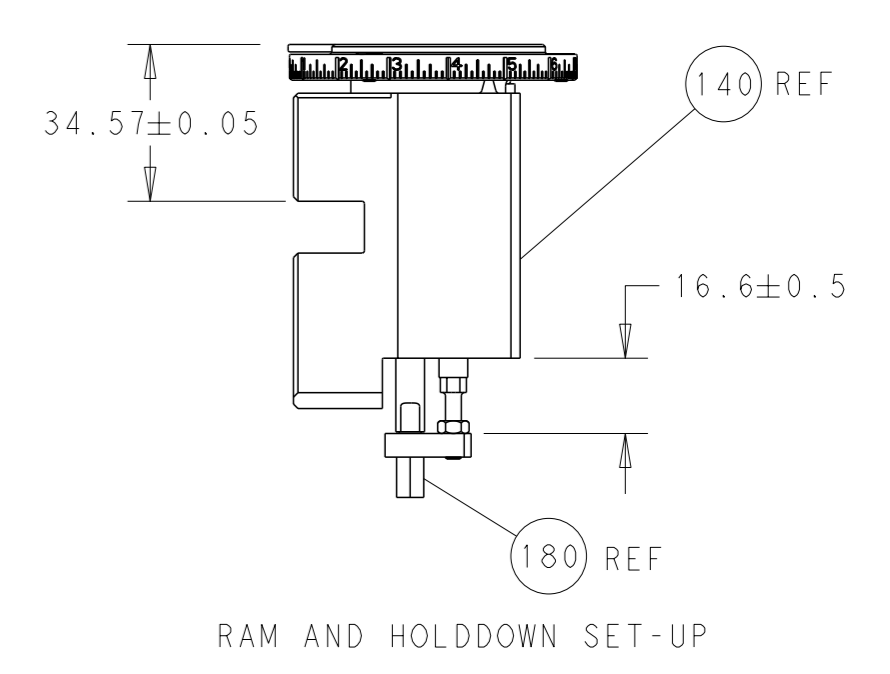
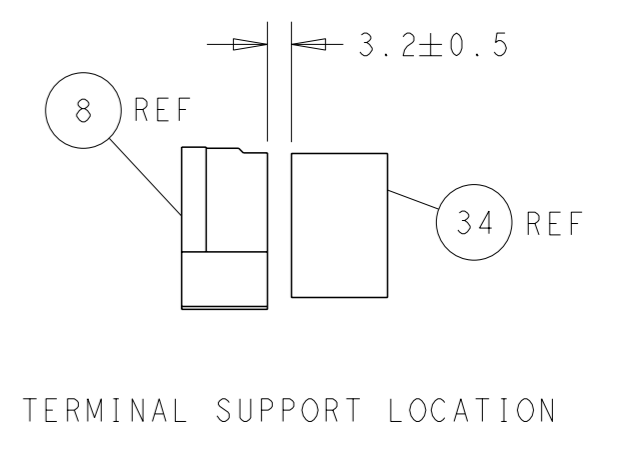
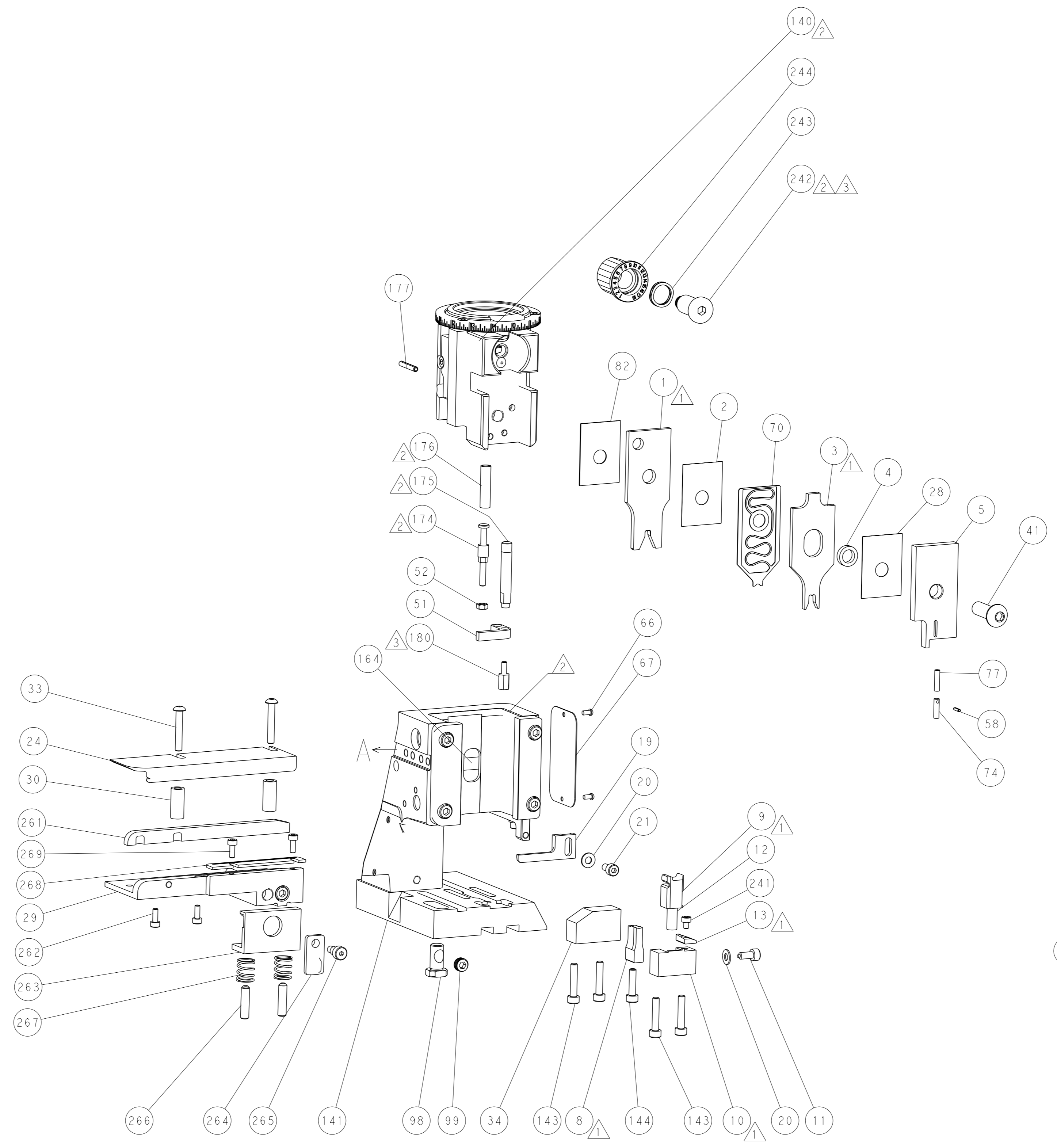
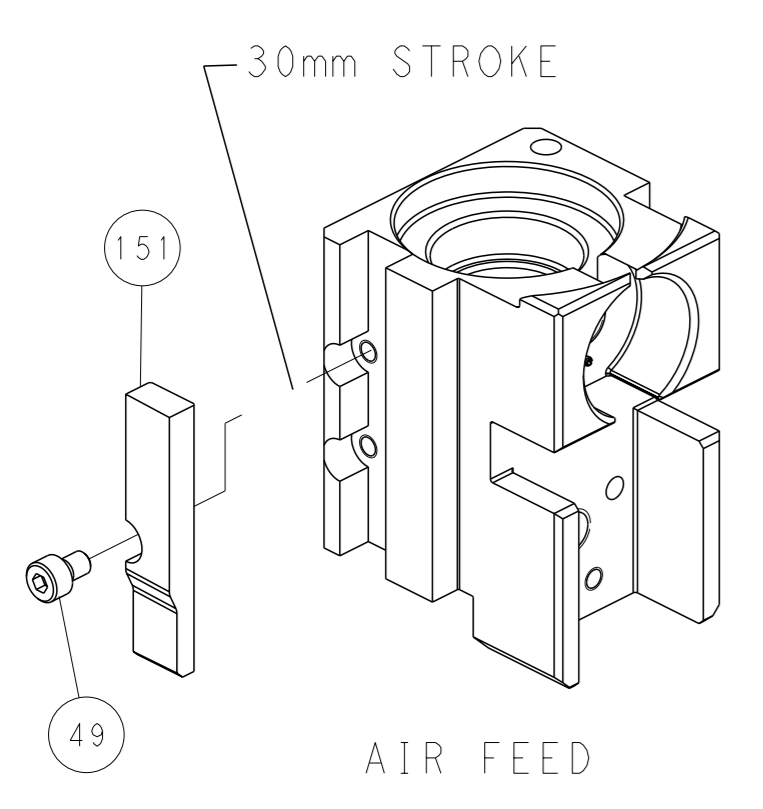

PACIFIC VERSION
 Shown on sheets 3 of 4 & 4 of 4
 (Atlantic version shown on sheets 1 of 4 & 2 of 4)

<small>THIS DRAWING IS A CONTROLLED DOCUMENT FOR TYCO ELECTRONICS CORPORATION. IT IS SUBJECT TO CHANGE AND THE CONTROLLER'S ENGINEERING DEPARTMENT SHOULD BE CONTACTED FOR THE LATEST REVISION.</small>		DWN C. CHEN 09JUN2013 CHK U. GUO 09JUN2013 APVD J. CRUZ 09JUN2013	STE TE Connectivity Harrisburg, PA 17105-3608
DIMENSIONS: mm TOLERANCES UNLESS OTHERWISE SPECIFIED: 0 PLC ± 1 PLC ± 2 PLC ± 3 PLC ± 4 PLC ± ANGLES FINISH ±		NAME Ocean Side Feed Applicator PRODUCT SPEC APPLICATION SPEC	SIZE CAGE CODE DRAWING NO. RESTRICTED TO A1 00779 C=2151971
MATERIAL:		WEIGHT:	SCALE 1:2 SHEET 4 OF 4 REV D Customer Accessible Production Drawing