

ECN/PCN No.: R0043

For Manufacturer			
Product Description: Bluetooth modules	Abracon Part Number / Part Series: ABBTM Bluetooth module series	<input type="checkbox"/> Documentation only <input type="checkbox"/> ECN <input checked="" type="checkbox"/> EOL	<input checked="" type="checkbox"/> Series <input type="checkbox"/> Part Number
Affected Revision: N/A	New Revision: EOL	Application: <input type="checkbox"/> Safety <input checked="" type="checkbox"/> Non-Safety	
Prior to Change: ABBTM-2.4GHZ, ABBTM-2.4GHZ-31, ABBTM-2.4GHZ-31-T, ABBTM-2.4GHZ-33, ABBTM-2.4GHZ-33-T, ABBTM-2.4GHZ-51, ABBTM-2.4GHZ-51-T, ABBTM-2.4GHZ-52, ABBTM-2.4GHZ-52-T, ABBTM-2.4GHZ-EVAL, ABBTM-2.4GHZ-T, ABBTM-2.4GHZ-T2, ABBTM-NVC-EVK-56, ABBTM-NVC-EVK-71, ABBTM-NVC-EVK-71-MESH, ABBTM-NVC-MB-EVK, ABBTM-NVC-MDCS42A-CON, ABBTM-NVC-MDCS71, ABBTM-NVC-MDCS71-CON, ABBTM-NVC-MDCS71-MESH, ABBTM-NVC-MDCS71-MESH-CON, ABBTM-NVC-MDCS71-101, ABBTM-NVC-MDCS86-101, ABBTM-101-2.4GHZ-T, ABBTM-2.4GHZ-51-101-, ABBTM-2.4GHZ-52-101, ABBTM-53-2.4GHZ-T, ABBTM-103-2.4GHZ-T, ABBTM-2.4GHZ-T; VER.10, ABBTM-NVC-MDCS42A-101, ABBTM-NVC-MDCS42A-F07, and ABBTM-NVC-MDCS56-102.			
After Change: All 32 EOL			
Cause/Reason for Change: Due to low demand, the Bluetooth Module ABBTM series is discontinued.			
Change Plan			
Effective Date: 06/08/2021	Additional Remarks: N/A		
Change Declaration: EOL			
Issued Date: 06/08/2021	Issued By: <i>Nicholas El-Takach</i>	Issued Department: Engineering	
Approval: <i>Syed Raza</i> Engineering VP	Approval: <i>Reuben Quintanilla</i> Quality Director	Approval: <i>Ying Huang</i> Purchasing Director	
For Abracon EOL only			
Last Time Buy (if applicable): No last time buy.	Alternate Part Number / Part Series: N/A		
Additional Approval:	Additional Approval:	Additional Approval:	
Customer Approval (If Applicable)			
Qualification Status: <input type="checkbox"/> Approved <input type="checkbox"/> Not accepted <i>Note: It is considered approved if there is no feedback from the customer 1 month after ECN/PCN is released.</i>			
Customer Part Number:		Customer Project:	
Company Name:	Company Representative:	Representative Signature:	
Customer Remarks:			

20.0 x 13.4 x 2.2 mm SMT Bluetooth Module

ABBTM-2.4GHz-51-T

Compliant to MSL level 3



RoHS
Compliant

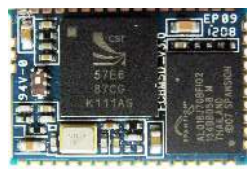

20.0 X 13.4 X 2.2MM

FEATURES:

- Bluetooth Spec v2.1 Compliant
- Class 2, up to 10-meter range
- Complete 2.4GHz Bluetooth® System
- Power management: low power 1.5V operation for Bluetooth® core
- Compact size: 20.0mm (L) x 13.4 (W) mm x 2.2mm (H)
- Bluetooth® Profile Supported: HSP, HFP, A2DP, AVRCP
- Built-in 16-bit stereo codec – 92dB SNR for DAC
- On-board flash memory (16 Mbits)
- Optional echo cancellation software library
- Support 802.11 co-existence
- Surface mount module for embedded applications
- Several firmware options
- Rewritable flash memory for easy upgrade route
- Custom firmware production available

APPLICATIONS:

- Stereo Bluetooth® headset/headphone
- Automotive car kit applications
- Personal Navigation Devices
- PDAs and other portable terminals
- MP3 headset
- High-end noise cancellation mono headset
- AV Dongle

GENERAL DESCRIPTION

Abracon's ABBTM-2.4GHz-51-T module is a complete Bluetooth® solution built on CSR BC05 MultiMedia External Core, supported by 16 Mbits on-board Flash Memory. ABBTM-2.4GHz-51-T is a short range, compact, cost effective solution designed to facilitate Bluetooth® connectivity for applications including PND, Car & Home Audio and other Handsfree solutions.

ABBTM-2.4GHz-51-T module is a Power Class-2 Bluetooth® device, compliant with version 2.1 specification. The overall architecture comprises of a radio front-end, antenna interface & supporting circuitry for software protocols including L2CAP, SDP, GAP, HSP, HFP, A2DP and AVRCP resident in the on-board Flash Memory.

ELECTRICAL SPECIFICATIONS:

Operating Frequency Band	2.4GHz ~ 2.48GHz Unlicensed ISM Band
Bluetooth Specification	V2.1
Output Power Class	Class 2
Operating Voltage	+3.3V
Host Interface	UART
Audio Interface	Analog
Flash Memory Size	16 Mbits

Absolute Maximum Ratings

	Minimum	Maximum
Storage temperature	-40°C	+105°C
Supply voltage: VBAT	-0.30V	3.6V

Recommended Operating Conditions

	Minimum	Maximum
Operating temperature range	-40°C	+85°C
Supply voltage: Vcc	+3.0V	+3.6V
Supply voltage: Vdd	+1.42V	+1.57V

Test Conditions: Vcc=3.3V; F=2.45GHz; T=20°C

ABRACON IS
ISO 9001:2008
CERTIFIED



ABRACON
CORPORATION

Visit www.abracon.com for Terms & Conditions of Sale
30332 Esperanza, Rancho Santa Margarita, California 92688
tel 949-546-8000 | fax 949-546-8001 | www.abracon.com

Revised: 01.14.15

20.0 x 13.4 x 2.2 mm SMT Bluetooth Module

ABBTM-2.4GHz-51-T



20.0 X 13.4 X 2.2MM

RF CHARACTERISTICS:

RF Characteristics @ Core Vdd=1.5V	Min.	Typ.	Max.	Bluetooth Specification	Unit	
Maximum RF transmit power ^{(a)(b)(c)}	-----	4	-----	-6 to 4 ^(d)	dBm	
RF power variation over temperature range with compensation enabled. ^(e)	----	±0.5	-----	-----	dB	
RF power variation over temperature range with compensation disabled. ^(e)	-----	±2.5	-----	-----	dB	
RF power control range	16	24	-----	≥16	dB	
RF power range control resolution ^(f)	-----	0.5	-----	-----	dB	
20dB bandwidth for modulated carrier	-----	940	1000	≤1000	kHz	
ACP ^(g) (h)	F = Fo ± 2MHz	-----	-36	-20	≤-20	dBm
	F = Fo ±3 MHz	-----	-45	-40	≤-40	dBm
	F = Fo ± > 3MHz	-----	<-50	-40	≤-40	dBm
Δf1avg Maximum modulation	140	165	175	140<f1avg<175	kHz	
Δf2max Minimum modulation	115	142	-----	≥115	kHz	
Δf1avg /Δf2avg	0.80	0.92	-----	≥0.80	-----	
Initial carrier frequency tolerance ⁽ⁱ⁾	-75	6	75	±75	kHz	
Drift rate	-----	6	20	≤20	kHz/50μs	
Drift(single slot packet)	-25	8	25	≤25	kHz	
Drift(five slot packet)	-40	10	40	≤40	kHz	
2 nd Harmonic content	-----	-32 ^(j)	-----	-----	dBm	
3 rd Harmonic content	-----	-32 ^(j)	-----	-----	dBm	

- (a) Results are referenced to the single ended port of the balun.
- (b) The Bluecore5-Multimedia External firmware maintains the transmit power within Bluetooth v2.1 + EDR specification limits.
- (c) Measurement made using appropriate PS Key settings.
- (d) Class 2 RF transmit power range, Bluetooth v2.1 + EDR specification.
- (e) Parameters depend on matching circuit used and behaviour over temperature. These parameters may be beyond CSR's direct control.
- (f) Resolution guaranteed over the range -5dB to -25dB relative to maximum power for TX level > 8dBm.
- (g) Measured at F₀ = 2441MHz.
- (h) BlueCore5-Multimedia External guaranteed to meet ACP performance in Bluetooth v2.1 + EDR specification.
- (i) Ignores any frequency error in the reference.
- (j) Filter will attenuate the harmonics.

20.0 x 13.4 x 2.2 mm SMT Bluetooth Module

ABBTM-2.4GHz-51-T



RoHS
Compliant

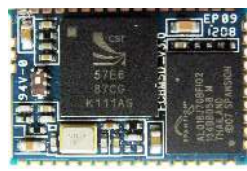

20.0 X 13.4 X 2.2MM

Ratio Characteristics @ Core Vdd=1.5V		Modulation	Min	Typ	Max	Bluetooth Specification	Unit
Sensitivity at 0.01% BER ^(a)	Ch 0	Π/4 DQPSK	-----	-93	-70	≤-70	dBm
	Ch 39		-----	-93	-70		
	Ch 78		-----	-92	-70		
	Ch 0	8 DPSK	-----	-85	-70	≤-70	dBm
	Ch 39		-----	-85	-70		
	Ch 78		-----	-84	-70		
Maximum received signal at 0.1% BER		Π/4 DQPSK	-20	>-10	----	≥-20	dBm
		8 DPSK	-20	>-10	----	≥-20	dBm
C/I co-channel at 0.1% BER ^{(b)(c)}		Π/4 DQPSK	-----	10	13	≤13	dB
		8 DPSK	-----	18	21	≤21	dB
Adjacent channel selectivity C/I ^{(b)(c)}	F=F ₀ + 1 MHz	Π/4 DQPSK	-----	-9	0	≤0	dB
		8 DPSK	-----	-2	5	≤5	dB
	F=F ₀ - 1 MHz	Π/4 DQPSK	-----	-10	0	≤0	dB
		8 DPSK	-----	-5	5	≤5	dB
	F=F ₀ + 2 MHz	Π/4 DQPSK	-----	-25	-20	≤-20	dB
		8 DPSK	-----	-22	-13	≤-13	dB
	F=F ₀ - 2 MHz	Π/4 DQPSK	-----	-41	-30	≤-30	dB
		8 DPSK	-----	-34	-25	≤-25	dB
	F=F ₀ - 3 MHz	Π/4 DQPSK	-----	-46	-40	≤-40	dB
		8 DPSK	-----	-38	-33	≤-33	dB
	F=F ₀ + 5 MHz	Π/4 DQPSK	-----	-48	-40	≤-40	dB
		8 DPSK	-----	-41	-33	≤-33	dB
	F= F _{image}	Π/4 DQPSK	-----	-12	-7	≤-7	dB
		8 DPSK	-----	-12	0	≤0	dB

(a) Dirty transmitter used.

(b) BlueCore5-Multimedia External is guaranteed to meet the C/I performance as specified by the Bluetooth v2.1 + EDR RF Test specification.

(c) Measured at F₀ = 2441MHz. However, depending on crystal frequency and channel number, then image may switch to the opposite side of the carrier. When this occurs, F_{image} = F₀ - 3MHz and the offsets in the table equations associated with C/I are also reversed.

20.0 x 13.4 x 2.2 mm SMT Bluetooth Module

ABBTM-2.4GHz-51-T



RoHS
Compliant

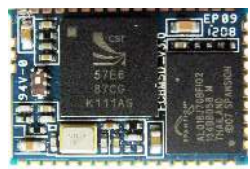

20.0 X 13.4 X 2.2MM

Firmware Configuration

- a) UART Baud: 115200 , N, 8, 1
- b) BlueTooth Name: BlueAudio
- c) Pin Code: 0000

Software Description

1. After Power on 3V3, the module is connectable and Pairing
2. ABBTM-2.4GHz-51-T can be found with the name “BlueAudio” via any Bluetooth device
3. Input the Pincode “0000”, you can pair with the module named “BlueAudio”
4. Then the BlueAudio can be connected
5. Data can be transferred between the BlueAudio and any other Bluetooth device

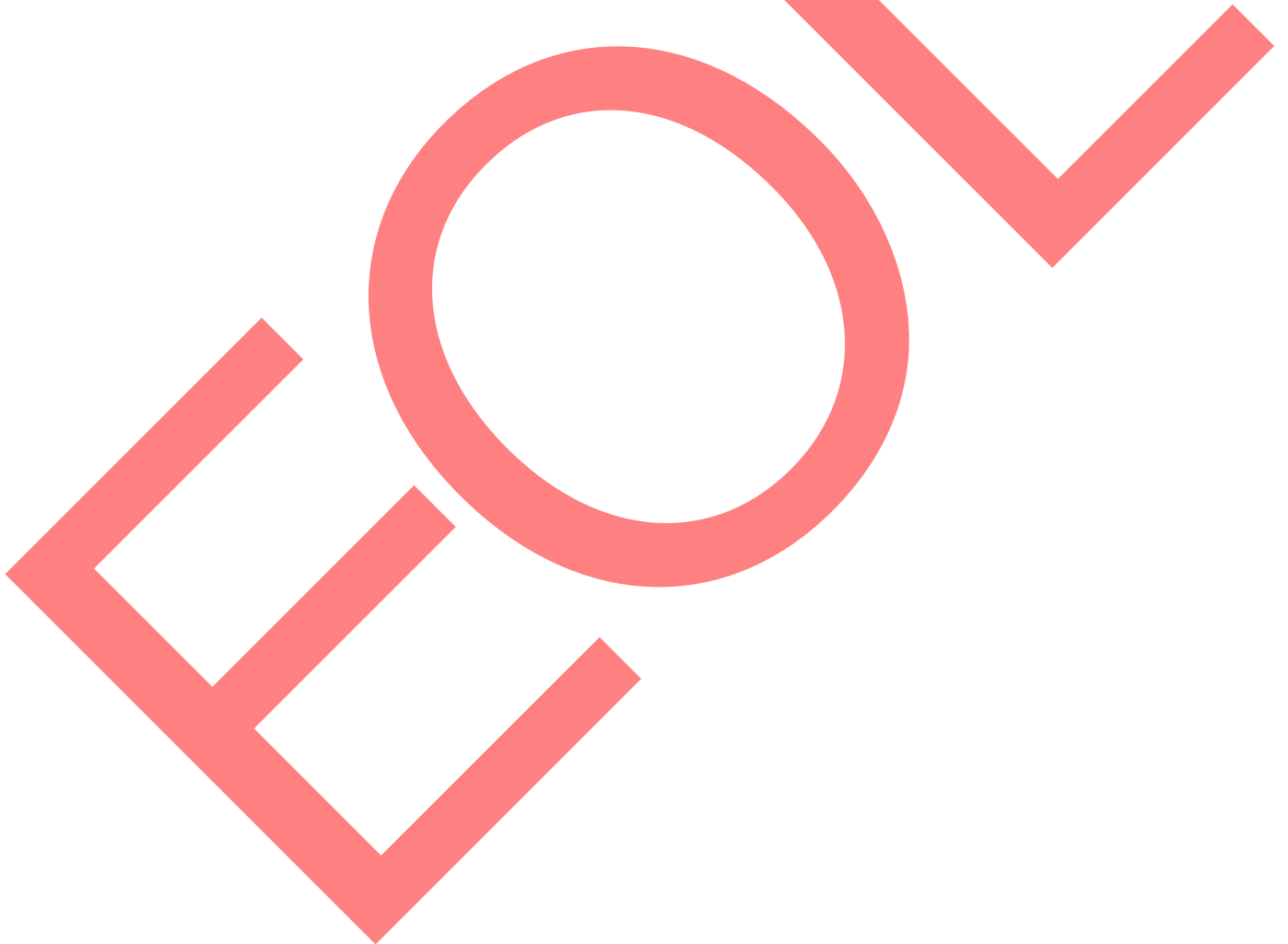

20.0 x 13.4 x 2.2 mm SMT Bluetooth Module

ABBTM-2.4GHz-51-T



20.0 X 13.4 X 2.2MM

APPLICATION SCHEMATIC

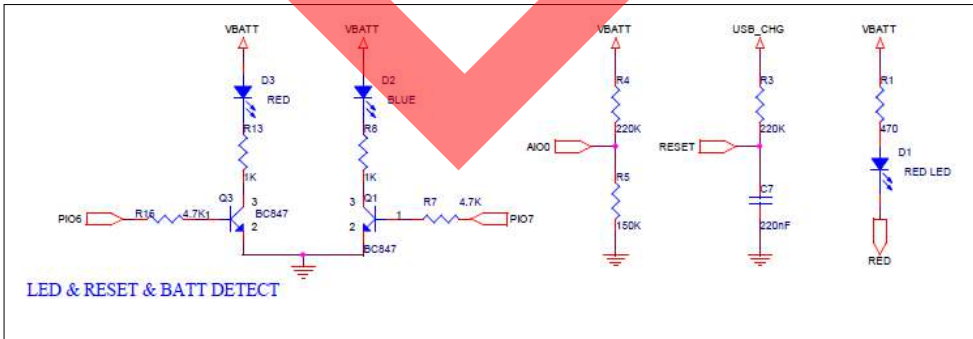
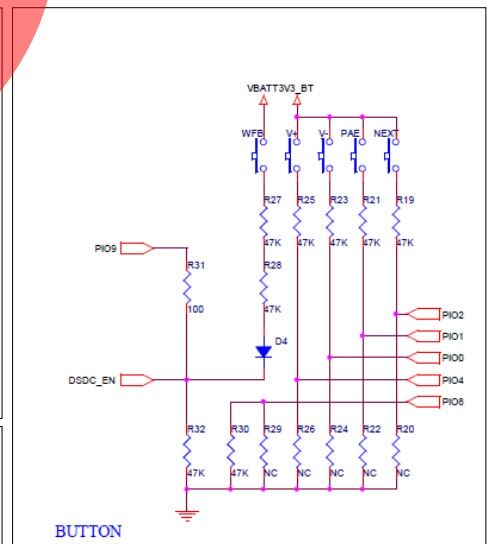
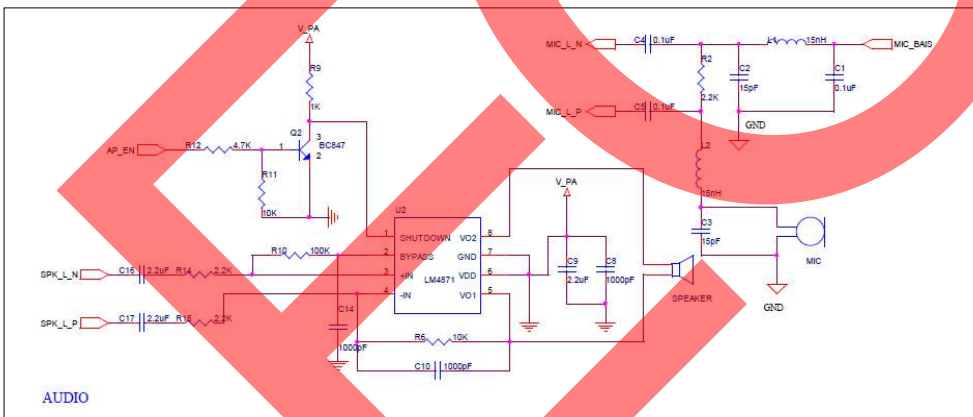
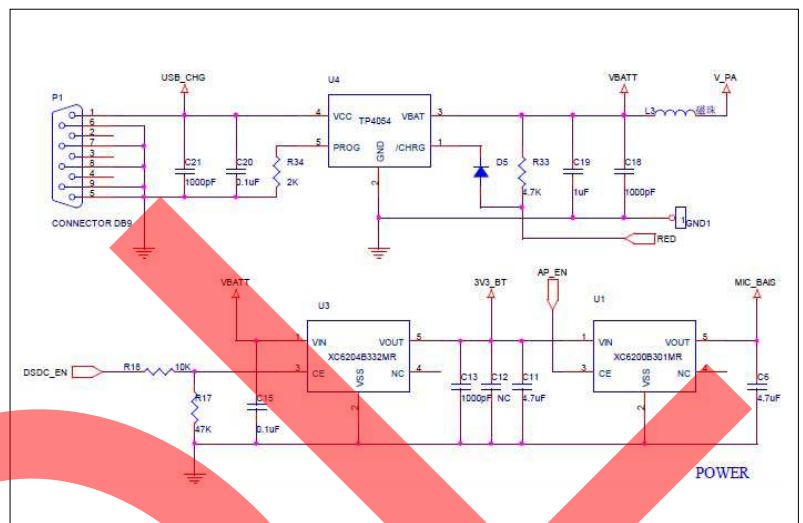
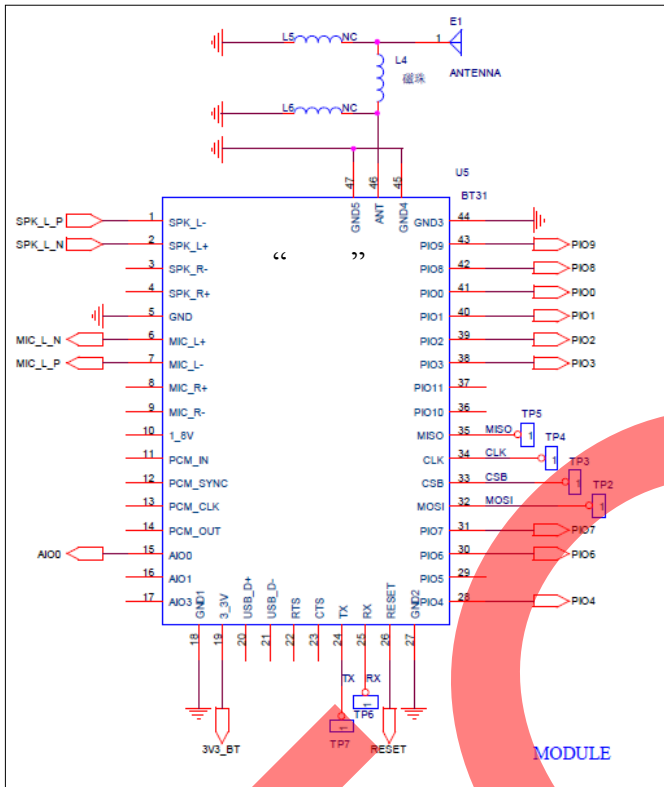

20.0 x 13.4 x 2.2 mm SMT Bluetooth Module

ABBTM-2.4GHz-51-T



RoHS
Compliant

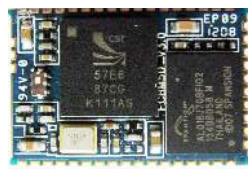

20.0 X 13.4 X 2.2MM

MECHANICAL DIMENSIONS

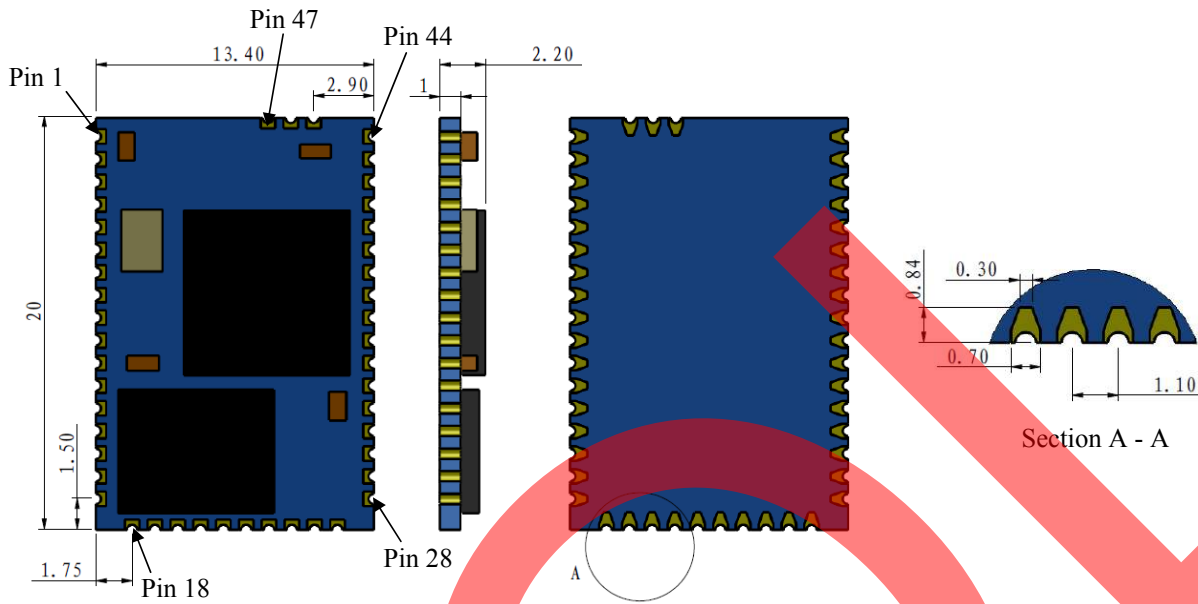

Recommended Land Pattern

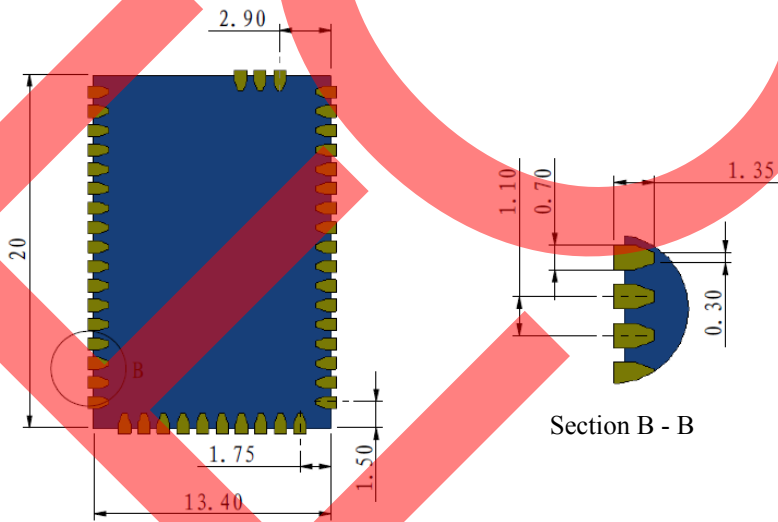

Note: Specified dimensions without tolerance are listed for reference purposes only.

Dimensions: mm.



20.0 x 13.4 x 2.2 mm SMT Bluetooth Module

ABBTM-2.4GHz-51-T



RoHS
Compliant

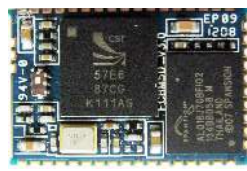

20.0 X 13.4 X 2.2MM

PIN DESCRIPTION

Pin No.	Name	Type	Function
1	SPK L-	Analogue	Speaker output negative(left side)
2	SPK L+	Analogue	Speaker output positive(left side)
3	SPK R-	Analogue	Speaker output negative(right side)
4	SPK R+	Analogue	Speaker output positive(right side)
5	GND	GND	Ground
6	MIC L+	Bi-directional	Programmable input/output line
7	MIC L-	Bi-directional	Programmable input/output line
8	MIC R+	Bi-directional	Programmable input/output line
9	MIC R-	Bi-directional	Programmable input/output line
10	1.8V	Power	Power output
11	PCM-IN	CMOS Input	Synchronous Data Input
12	PCM-SYNC	Bi-directional	Synchronous Data Sync
13	PCM-CLK	Bi-directional	Synchronous Data Clock
14	PCM-OUT	CMOS Output	Synchronous Data Output
15	AIO0	Bi-directional	Programmable input/output line
16	AIO1	Bi-directional	Programmable input/output line
17	AIO3	Bi-directional	Programmable input/output line
18	GND	GND	Ground
19	3.3V	Power	+3.3V Supply
20	N.C.	Not Connected	
21	N.C.	Not Connected	
22	RTS	CMOS Output, tri-state, with weak internal pull-up	UART request to send active low
23	CTS	CMOS Input with weak internal pull-down	UART clear to send active low
24	TX	CMOS Output, tri-state, with weak internal pull-up	UART data output
25	RX	CMOS Input with weak internal pull-down	UART data input
26	RESET	CMOS Input	Reset if High
27	GND	GND	Ground
28	PIO4	Bi-directional with programmable strength	PIO
29	PIO5	Bi-directional with programmable strength	PIO
30	PIO6	Bi-directional with programmable strength	PIO line or clock request output to enable external clock for external clock line
31	PIO7	Bi-directional with programmable strength	Programmable input/output line or programmable frequency clock output
32	MOSI	CMOS Input	Serial Peripheral Interface Data Input
33	CSB	CMOS Input	Chip Select for Synchronous Serial Interface (active low)
34	CLK	CMOS Input	Serial Peripheral Interface Clock
35	MISO	CMOS Output	Serial Peripheral Interface Data Output
36	PIO10	Bi-directional	Programmable input/output line
37	PIO11	Bi-directional	Programmable input/output line
38	PIO3	Bi-directional with programmable strength	PIO
39	PIO2	Bi-directional with programmable strength	PIO or external clock request
40	PIO1	Bi-directional with programmable strength	Control output for external PA (if fitted)
41	PIO0	Bi-directional with programmable strength	Control output for external Tx/Rx switch (if fitted)
42	PIO8	Bi-directional	Programmable input/output line
43	PIO9	Bi-directional	Programmable input/output line
44	GND	GND	Ground
45	GND	GND	Ground
46	ANT	RF	RF Interface
47	GND	GND	Ground

20.0 x 13.4 x 2.2 mm SMT Bluetooth Module

ABBTM-2.4GHz-51-T



RoHS
Compliant



20.0 X 13.4 X 2.2MM

REFLOW PROFILE

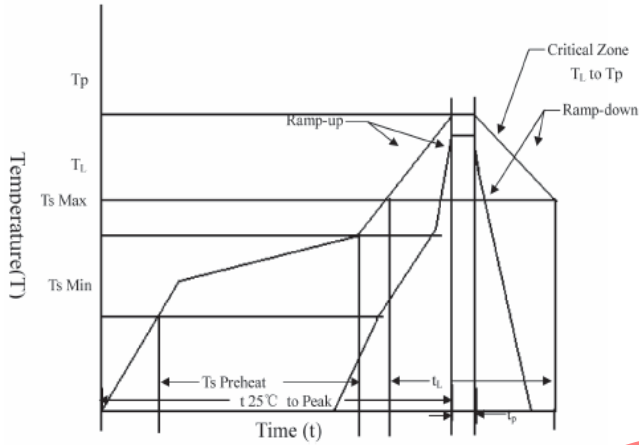

T _S max to T _L (Ramp-up Rate)	3°C/second max.
Preheat	
Temperature Min. (T _S Min.)	150°C
Temperature Typical (T _S Typ.)	175°C
Temperature Max. (T _S Max.)	200°C
Time (t _s)	60 ~ 180 seconds
Ramp-up rate (T _L to T _p)	3°C/second max.
Time Maintained Above:	
--Temperature (T _L)/Time (t _L)	217°C/60 ~ 150 seconds
Peak Temperature (T _p)	250°C max. for 10 seconds
Target Peak Temperature (T _p Target)	250°C +0/-5°C
Time within 5°C of actual peak (t _p)	20 ~ 40 seconds
Ramp-down Rate	6°C/second max.
Tune 25°C to Peak Temperature (t)	8 minutes max.

PACKAGING:

500pcs/reel

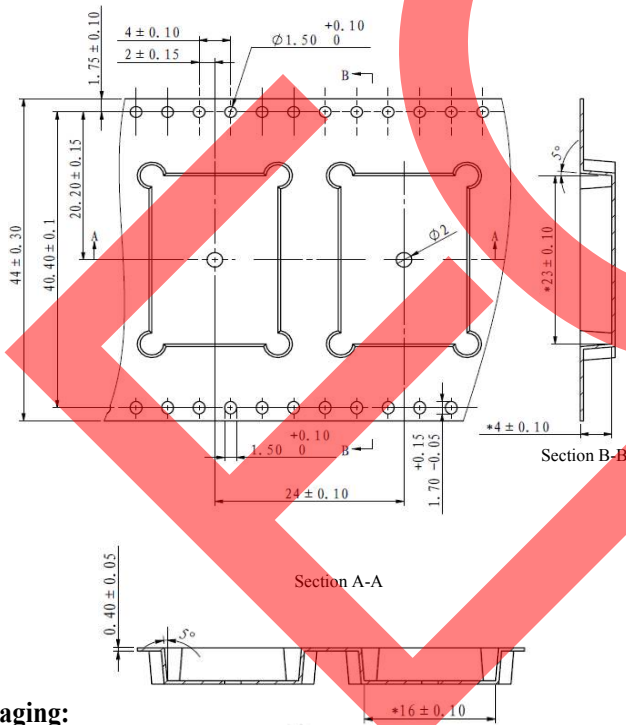

包装要求:
500 pcs/Reel

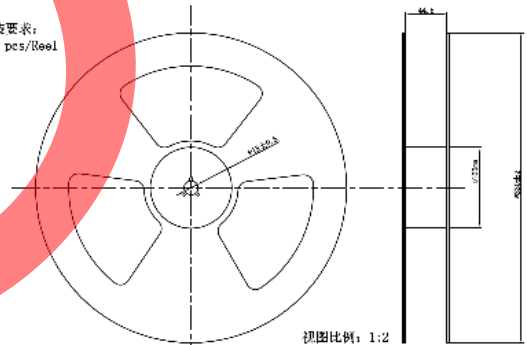

视图比例: 1:2

- Unless otherwise specified, the tolerance is ± 0.1 mm
- The carrier tape material thickness is 0.4mm
- Unless otherwise specified, the round corner is R0.3; the peeling angle is no greater than 5°
- The finished products has no rough edges and no damage; cover tape should be sealed
- Material is ROHS compliant

Packaging:

ABBTM-2.4GHz-51-T devices will be packaged per MSL level-3 requirements; Labeled as MSL 3, Tape- Packed + Vacuum-Packed with Antistatic bag, Desiccant, Humidity Indicator Card (HIC). Ref: IPC/JEDEC J-STD-033B.1

ATTENTION: Abracon Corporation's products are COTS – Commercial-Off-The-Shelf products; suitable for Commercial, Industrial and, where designated, Automotive Applications. Abracon's products are not specifically designed for Military, Aviation, Aerospace, Life-dependant Medical applications or any application requiring high reliability where component failure could result in loss of life and/or property. For applications requiring high reliability and/or presenting an extreme operating environment, written consent and authorization from Abracon Corporation is required. Please contact Abracon Corporation for more information.

ABRACON IS
ISO 9001:2008
CERTIFIED



Visit www.abracon.com for Terms & Conditions of Sale
30332 Esperanza, Rancho Santa Margarita, California 92688
tel 949-546-8000 | fax 949-546-8001 | www.abracon.com

Revised: 01.14.15