

REVISIONS					
P	LTR	DESCRIPTION	DATE	OWN	APVD
P		REVISED PER ECO-15-015252	12NOV15	BJ	FY

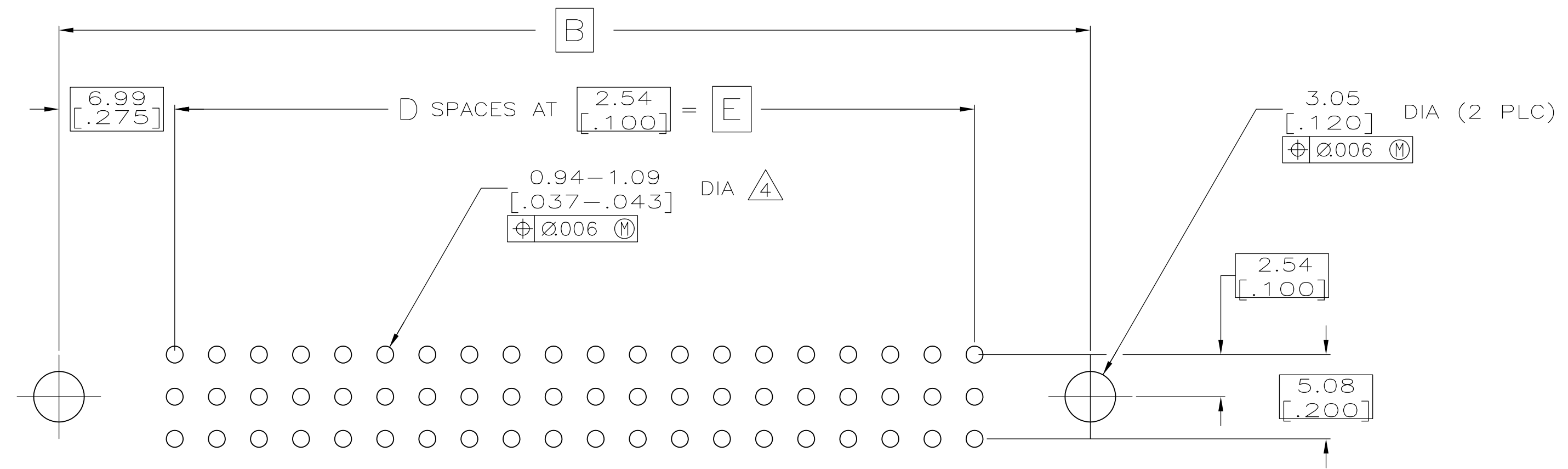
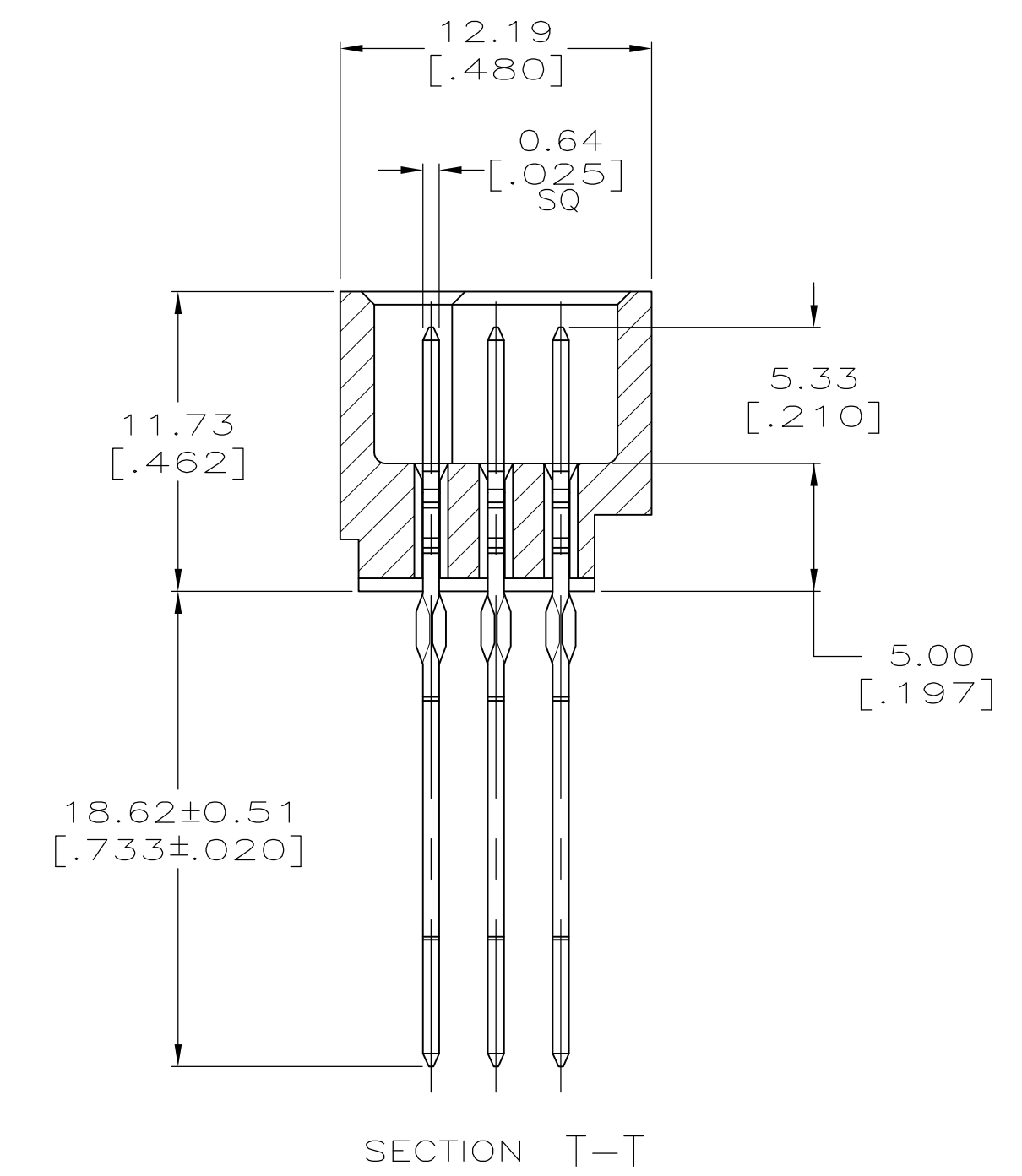
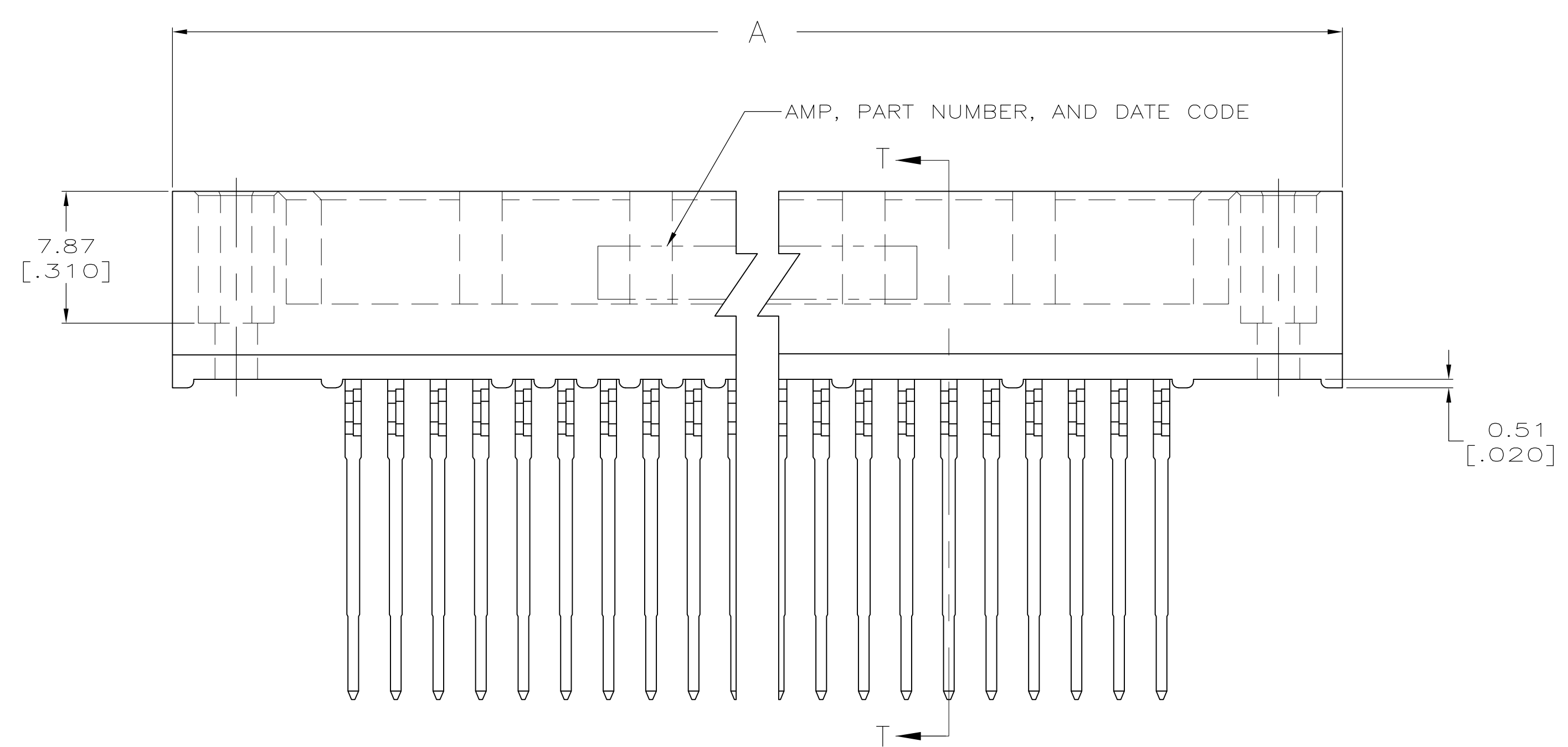
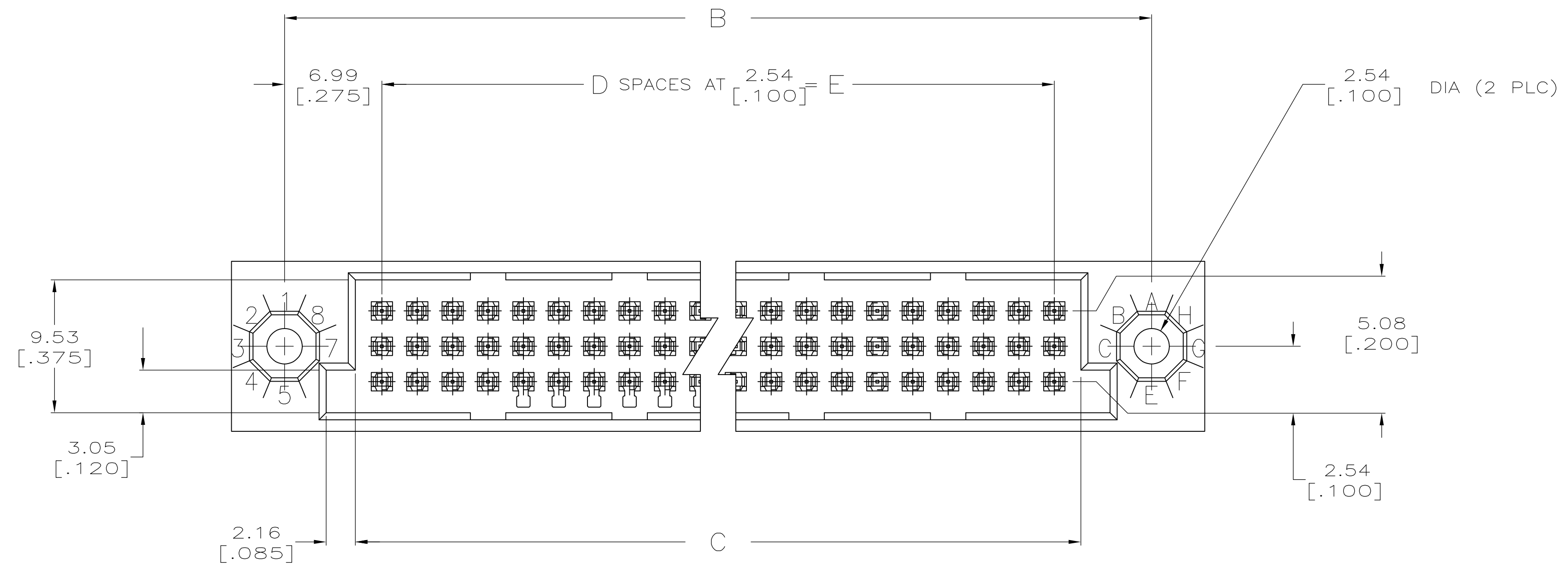

RECOMMENDED P.C. BOARD LAYOUT

THIS DRAWING IS A CONTROLLED DOCUMENT.		DIN R.K. SEIFRIED 03/26/90	TE Connectivity	
		CHK F. KIBLER 8-18-92		
DIMENSIONS: mm [INCHES]		TOLERANCES UNLESS OTHERWISE SPECIFIED:		NAME HDI, 3 ROW, PIN ASSEMBLY, 18.62 [.733] LONG ACTION PINS
		0 PLC ± -	PRODUCT SPEC	SIZE A1
		1 PLC ± -	APPLICATION SPEC	CAGE CODE 00779
		2 PLC ± -	FINISH	DRAWING NO. 532432
		3 PLC ± 0.13 [.005]	WEIGHT	RESTRICTED TO
		4 PLC ± -	CUSTOMER DRAWING	SCALE 4:1
		ANGLES ± -		SHEET 1 OF 2
				REV P

REVISIONS				
P	LTR	DESCRIPTION	DATE	APPV
-		SEE SHEET 1	-	-

- ① HOUSING MATERIAL: THERMOPLASTIC, COLOR-BLACK.
- ② CONTACT MATERIAL: PHOSPHOR BRONZE.
- ③ FINISH:  
MATING AREA: MEETS THE PERFORMANCE REQUIREMENTS OF PRODUCT SPECIFICATION 108-9063; BASED ON TELCORDIA DR-1217-CORE APPLICATIONS IN UNCONTROLLED ENVIRONMENTS.  
SOLDER TAILS AREA: TIN-LEAD PLATED.
- ④ ACTION PIN POSTS REQUIRE 2.36 [.093] MIN THICK P.C. BOARD. RECOMMENDED P.C. BOARD HOLES ARE 1.151 [.0453] DIA PLATED THRU WITH 0.025-0.076 [.001-.003] COPPER, WITH 0.0076 [.0003] MIN TIN-LEAD PLATING; FINISHED HOLE AFTER PLATING 0.94-1.09 [.037-.043] DIA.
- 5. DIMENSIONS IN BRACKETS ARE IN INCHES.
- ⑥ HOUSINGS WITH CENTER MOUNTING IS RECOMMENDED FOR ASSEMBLIES HAVING 75 CONTACTS PER ROW OR MORE.
- ⑦ PART NUMBER IS OBSOLETE.

⑥⑦	—	—	—	—	—	—	2-532432-0
⑥⑦	—	—	—	—	—	—	1-532432-9
⑥⑦	—	—	—	—	—	—	1-532432-8
⑥⑦	—	—	—	—	—	—	1-532432-7
⑥⑦	—	—	—	—	—	—	1-532432-6
⑥⑦	—	—	—	—	—	—	1-532432-5
⑥⑦	—	—	—	—	—	—	1-532432-4
⑥⑦	—	—	—	—	—	—	1-532432-3
①	187.96 [7.400]	74	191.77 [7.550]	201.93 [7.950]	209.55 [8.250]	225	1-532432-2
①	175.26 [6.900]	69	179.07 [7.050]	189.23 [7.450]	196.85 [7.750]	210	1-532432-1
①	—	—	—	—	—	—	1-532432-0
①	149.86 [5.900]	59	153.67 [6.050]	163.83 [6.450]	171.45 [6.750]	180	532432-9
①	137.16 [5.400]	54	140.97 [5.550]	151.13 [5.950]	158.75 [6.250]	165	532432-8
①	—	—	—	—	—	—	532432-7
①	—	—	—	—	—	—	532432-6
①	99.06 [3.900]	39	102.87 [4.050]	113.03 [4.450]	120.65 [4.750]	120	532432-5
①	—	—	—	—	—	—	532432-4
①	78.74 [3.100]	31	82.55 [3.250]	92.71 [3.650]	100.33 [3.950]	96	532432-3
①	—	—	—	—	—	—	532432-2
①	—	—	—	—	—	—	532432-1
	E	D	C	B	A	POSN	PART NUMBER

THIS DRAWING IS A CONTROLLED DOCUMENT.		DIN R. K. SEIFRIED 03/26/90 CHK F. KIBLER 8-18-92		 TE Connectivity	
DIMENSIONS: mm [INCHES]		TOLERANCES UNLESS OTHERWISE SPECIFIED:		NAME HDI, 3 ROW, PIN ASSEMBLY, 18.62 [.733] LONG ACTION PINS	
0 PLC ± - 1 PLC ± - 2 PLC ± - 3 PLC ± 0.13 [.005] 4 PLC ± - ANGLES ± -		PRODUCT SPEC APPLICATION SPEC		SIZE CAGE CODE DRAWING NO	
MATERIAL ①②		FINISH ③		WEIGHT 0 A1 00779 532432	
CUSTOMER DRAWING				SCALE 4:1 SHEET 2 OF 2 REV P	