

- 1
- 2
- 3
- 4
- 5
- 6
- 7
- 8
- 9
- 10
- 11
- 12
- 13
- 14
- 15
- RH

BASE AND CASE

High-resistance polyamide based (PA) technopolymer.
Black base.

Case in the following colours:

- **C2**: RAL 2004 orange, glossy finish.
- **C3**: RAL 7035 grey, glossy finish.
- **C1**: RAL 7021 grey-black, glossy finish.

The ultrasonically welding between the base and the case prevents separation and avoids dust penetration.

WINDOW

Transparent polyamide based (PA-T) technopolymer, moulded over the case and with a perfect seal. Resistant to solvents, oils, greases (avoid contact with alcohol during cleaning operations).

DISPLAY

It indicates the displacement of the mechanism controlled by the spindle from the start position (0). Three-digit roller counter (two black rolls and one red roll or one black roll and two red rolls, three black rolls on request). The digits of red rolls show the decimal values. The display can be in different positions (see "Table of the possible combinations").

- **AN**: inclined display, counter in upper position.
- **AR**: inclined display, counter in lower position.
- **FN**: front display, counter in upper position.
- **FR**: front display, counter in lower position.

INTERNAL GASKET

O-ring front sealing in NBR synthetic rubber, between the case and the boss.

REAR GASKET

Foam polyethylene, supplied.

STANDARD EXECUTION

Boss with DIA 0.375 (Ø 9.52 mm) reamed hole, fitting to shaft by means of a supplied grub screw with hexagon socket and cup end.

- **DD50**: black-oxide steel boss.
- **DD50-SST**: AISI 303 stainless steel boss.

DIRECTION OF ROTATION

- **D**: clockwise. Increasing values with clockwise rotation of the boss.
- **S**: anti-clockwise. Increasing values with anti-clockwise rotation of the boss.

WEIGHT

0.044 lbs.

ERGONOMY AND DESIGN

Compact roller counter, ergonomically designed digits for rapid reading. The readability of the counter is increased by the magnifying window.

ASSEMBLY INSTRUCTIONS

1. Drill a DIA 0.24 by 0.39 (Ø 6 mm by 10 mm) hole in the body of the machine with a 0.71 inches (18 mm) centre distance from the spindle to fit the rear referring pin.
2. Set the spindle to the start or referring position.
3. Fit the indicator with the zeroed roller counter onto the spindle and make sure that the referring pin fit the hole.
4. Clamp the boss to the spindle by tightening the grub screw with hexagon socket and cup end.

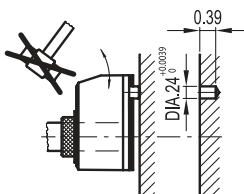

ELESA Original design

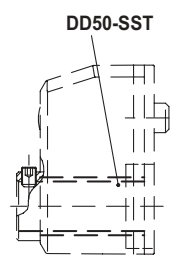
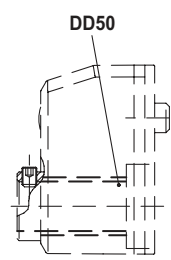
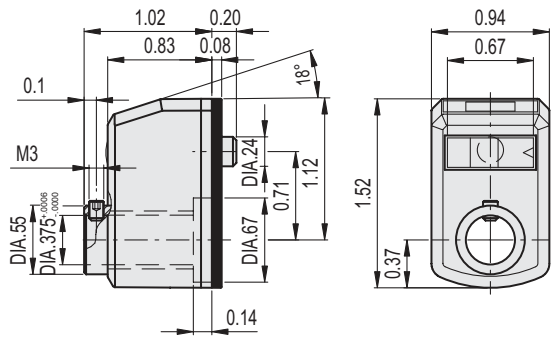

SPECIAL EXECUTIONS ON REQUEST

- Special readings after one revolution.
- Case in different colours.
- Completely sealed digital position indicators with IP 67 protection class, see IEC 529 table (on page A-19), obtained by means of a brass bushing with double seal ring inside the rear cavity of the base.

FEATURES AND APPLICATIONS

Direct drive digital position indicators can be assembled on passing through spindles in any position to give direct reading of the positioning of a machine component. They are suitable also for motor driven applications (see "Table of the possible combinations").

ACCESSORIES ON REQUEST (TO BE ORDERED SEPARATELY)

- **RB50**: black-oxide steel reduction sleeves.
- **RB50-SST**: AISI 304 stainless steel reduction sleeves.

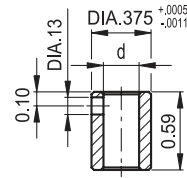

RB50

INCH

Code	Description	d
CE980940	RB50-3/8-1/4	0.250+.0006











RB50-SST

INOX STAINLESS STEEL

INCH

Code	Description	d
CE990940	RB50-3/8-1/4-SST	0.250+.0006

Example of description for ordering

DD50	-	AN	-	010	-	D	-	C2	-	SST
Series		Display position		Reading of the counter after one revolution		Increasing numbering		Colour		Stainless steel boss
 AN inclined upper		 AR inclined lower				 D clockwise		 C2 RAL 2004		 To add only for the version with stainless steel boss
 FN front upper		 FR front lower				 S anti-clockwise		 C3 RAL 7035		
								 C1 RAL 7021		

010	01.0	0.10	Pitch		Speed (rpm)*
			threads per inch	inches per threads	
010	01.0	0.10	10	1.0	1500
020	02.0	0.20	5	2.0	1250
030	03.0	0.30	-	3.0	830
040	04.0	0.40	2.5	4.0	625
050	05.0	0.50	-	5.0	500
100	10.0	1.00	-	10	250

* The maximum rotation speed (rpm) of the spindle reported in the table corresponds to a maximum rotation of 2500 units of the last roll on the right of the counter. Rotational speed tests have been performed in our laboratory under standard operating conditions. It is recommended not to subject the product to sudden acceleration and / or sudden stop.



Position indicators