

National Semiconductor is now part of
Texas Instruments.

Search <http://www.ti.com/> for the latest technical
information and details on our current products and services.

LM10

Operational Amplifier and Voltage Reference

General Description

The LM10 series are monolithic linear ICs consisting of a precision reference, an adjustable reference buffer and an independent, high quality op amp.

The unit can operate from a total supply voltage as low as 1.1V or as high as 40V, drawing only 270 μ A. A complementary output stage swings within 15 mV of the supply terminals or will deliver ± 20 mA output current with ± 0.4 V saturation. Reference output can be as low as 200 mV.

The circuit is recommended for portable equipment and is completely specified for operation from a single power cell. In contrast, high output-drive capability, both voltage and current, along with thermal overload protection, suggest it in demanding general-purpose applications.

The device is capable of operating in a floating mode, independent of fixed supplies. It can function as a remote comparator, signal conditioner, SCR controller or transmitter for

analog signals, delivering the processed signal on the same line used to supply power. It is also suited for operation in a wide range of voltage- and current-regulator applications, from low voltages to several hundred volts, providing greater precision than existing ICs.

This series is available in the three standard temperature ranges, with the commercial part having relaxed limits. In addition, a low-voltage specification (suffix "L") is available in the limited temperature ranges at a cost savings.

Features

- input offset voltage: 2.0 mV (max)
- input offset current: 0.7 nA (max)
- input bias current: 20 nA (max)
- reference regulation: 0.1% (max)
- offset voltage drift: 2 μ V/ $^{\circ}$ C
- reference drift: 0.002%/ $^{\circ}$ C

Connection and Functional Diagrams

Metal Can Package (H)

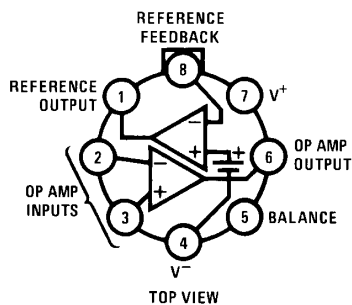

DS005652-1

Order Number LM10BH, LM10CH, LM10CLH or LM10H/883
available per SMA# 5962-8760401
See NS Package Number H08A

Small Outline Package (WM)

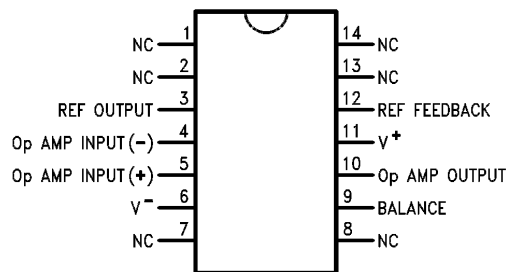

DS005652-17

Order Number LM10CWM or LM10CWMX
See NS Package Number M14B

Dual-In-Line Package (N)

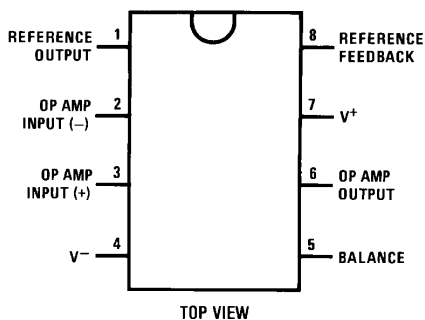

DS005652-15

Order Number LM10CN or LM10CLN
See NS Package Number N08E

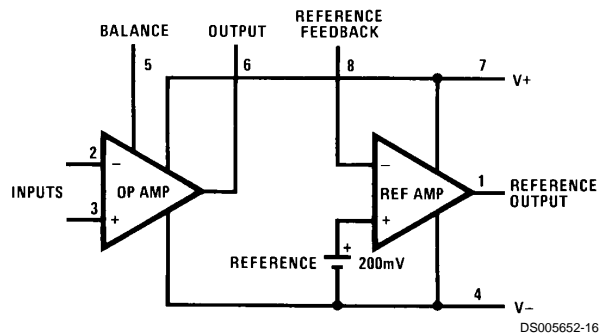

DS005652-16

Absolute Maximum Ratings (Notes 1, 8)

If Military/Aerospace specified devices are required, please contact the National Semiconductor Sales Office/Distributors for availability and specifications.

	LM10/LM10B/ LM10BL/	
	LM10C	LM10CL
Total Supply Voltage	45V	7V
Differential Input Voltage (Note 2)	±40V	±7V
Power Dissipation (Note 3)	internally limited	
Output Short-circuit Duration (Note 4)	continuous	
Storage-Temp. Range	-55°C to +150°C	
Lead Temp. (Soldering, 10 seconds)		
Metal Can	300°C	
Lead Temp. (Soldering, 10 seconds) DIP	260°C	
Vapor Phase (60 seconds)	215°C	
Infrared (15 seconds)	220°C	

See AN-450 "Surface Mounting Methods and Their Effect on Product Reliability" for other methods of soldering surface mount devices.

Electrical Characteristics

$T_J=25^\circ\text{C}$, $T_{\text{MIN}} \leq T_J \leq T_{\text{MAX}}$ (Boldface type refers to limits over temperature range) (Note 5)

Parameter	Conditions	LM10/LM10B			LM10C			Units
		Min	Typ	Max	Min	Typ	Max	
Input offset voltage			0.3	2.0		0.5	4.0	mV
				3.0			5.0	mV
Input offset current (Note 6)			0.25	0.7		0.4	2.0	nA
				1.5			3.0	nA
Input bias current			10	20		12	30	nA
				30			40	nA
Input resistance		250	500		150	400		kΩ
		150			115			kΩ
Large signal voltage gain	$V_S = \pm 20\text{V}$, $I_{\text{OUT}} = 0$	120	400		80	400		V/mV
	$V_{\text{OUT}} = \pm 19.95\text{V}$	80			50			V/mV
	$V_S = \pm 20\text{V}$, $V_{\text{OUT}} = \pm 19.4\text{V}$	50	130		25	130		V/mV
	$I_{\text{OUT}} = \pm 20\text{ mA}$ (±15 mA)	20			15			V/mV
	$V_S = \pm 0.6\text{V}$ (0.65V), $I_{\text{OUT}} = \pm 2\text{ mA}$	1.5	3.0		1.0	3.0		V/mV
	$V_{\text{OUT}} = \pm 0.4\text{V}$ (±0.3V), $V_{\text{CM}} = -0.4\text{V}$	0.5			0.75			V/mV
Shunt gain (Note 7)	1.2V (1.3V) $\leq V_{\text{OUT}} \leq 40\text{V}$, $R_L = 1.1\text{ k}\Omega$	14	33		10	33		V/mV
	$0.1\text{ mA} \leq I_{\text{OUT}} \leq 5\text{ mA}$	6			6			V/mV
	$1.5\text{V} \leq V^+ \leq 40\text{V}$, $R_L = 250\Omega$	8	25		6	25		V/mV
	$0.1\text{ mA} \leq I_{\text{OUT}} \leq 20\text{ mA}$	4			4			V/mV
Common-mode rejection	$-20\text{V} \leq V_{\text{CM}} \leq 19.15\text{V}$ (19V)	93	102		90	102		dB
	$V_S = \pm 20\text{V}$	87			87			dB
Supply-voltage rejection	$-0.2\text{V} \geq V^- \geq -39\text{V}$	90	96		87	96		dB
	$V^+ = 1.0\text{V}$ (1.1V)	84			84			dB
	1.0V (1.1V) $\leq V^+ \leq 39.8\text{V}$	96	106		93	106		dB
	$V^- = -0.2\text{V}$	90			90			dB
Offset voltage drift			2.0			5.0		$\mu\text{V}/^\circ\text{C}$
Offset current drift			2.0			5.0		$\text{pA}/^\circ\text{C}$
Bias current drift	$T_C < 100^\circ\text{C}$		60			90		$\text{pA}/^\circ\text{C}$
Line regulation	1.2V (1.3V) $\leq V_S \leq 40\text{V}$		0.001	0.003		0.001	0.008	%/V
	$0 \leq I_{\text{REF}} \leq 1.0\text{ mA}$, $V_{\text{REF}} = 200\text{ mV}$			0.006			0.01	%/V

ESD rating is to be determined.

Maximum Junction Temperature

LM10	150°C
LM10B	100°C
LM10C	85°C

Operating Ratings

Package Thermal Resistance

θ_{JA}		
H Package	150°C/W	
N Package	87°C/W	
WM Package	90°C/W	
θ_{JC}		
H Package	45°C/W	

Electrical Characteristics (Continued)

$T_J=25^\circ\text{C}$, $T_{\text{MIN}} \leq T_J \leq T_{\text{MAX}}$ (Boldface type refers to limits over temperature range) (Note 5)

Parameter	Conditions	LM10/LM10B			LM10C			Units
		Min	Typ	Max	Min	Typ	Max	
Load regulation	$0 \leq I_{\text{REF}} \leq 1.0 \text{ mA}$ $V^+ - V_{\text{REF}} \geq 1.0 \text{ V}$ (1.1V)		0.01	0.1		0.01	0.15	%
				0.15			0.2	%
Amplifier gain	$0.2 \text{ V} \leq V_{\text{REF}} \leq 35 \text{ V}$	50	75		25	70		V/mV
		23			15			V/mV
Feedback sense voltage		195	200	205	190	200	210	mV
		194		206	189		211	mV
Feedback current			20	50		22	75	nA
				65			90	nA
Reference drift			0.002			0.003		%/°C
Supply current			270	400		300	500	μA
				500			570	μA
Supply current change	1.2 V (1.3V) $\leq V_S \leq 40 \text{ V}$		15	75		15	75	μA

Electrical Characteristics

$T_J=25^\circ\text{C}$, $T_{\text{MIN}} \leq T_J \leq T_{\text{MAX}}$ (Boldface type refers to limits over temperature range) (Note 5)

Parameter	Conditions	LM10BL			LM10CL			Units
		Min	Typ	Max	Min	Typ	Max	
Input offset voltage			0.3	2.0		0.5	4.0	mV
				3.0			5.0	mV
Input offset current (Note 6)			0.1	0.7		0.2	2.0	nA
				1.5			3.0	nA
Input bias current			10	20		12	30	nA
				30			40	nA
Input resistance		250	500		150	400		kΩ
		150			115			kΩ
Large signal voltage gain	$V_S = \pm 3.25 \text{ V}$, $I_{\text{OUT}} = 0$	60	300		40	300		V/mV
	$V_{\text{OUT}} = \pm 3.2 \text{ V}$	40			25			V/mV
	$V_S = \pm 3.25 \text{ V}$, $I_{\text{OUT}} = 10 \text{ mA}$	10	25		5	25		V/mV
	$V_{\text{OUT}} = \pm 2.75 \text{ V}$	4			3			V/mV
	$V_S = \pm 0.6 \text{ V}$ (0.65V), $I_{\text{OUT}} = \pm 2 \text{ mA}$	1.5	3.0		1.0	3.0		V/mV
	$V_{\text{OUT}} = \pm 0.4 \text{ V}$ (±0.3V), $V_{\text{CM}} = -0.4 \text{ V}$	0.5			0.75			V/mV
Shunt gain (Note 7)	$1.5 \text{ V} \leq V^+ \leq 6.5 \text{ V}$, $R_L = 500 \Omega$	8	30		6	30		V/mV
	$0.1 \text{ mA} \leq I_{\text{OUT}} \leq 10 \text{ mA}$	4			4			V/mV
Common-mode rejection	$-3.25 \text{ V} \leq V_{\text{CM}} \leq 2.4 \text{ V}$ (2.25V)	89	102		80	102		dB
	$V_S = \pm 3.25 \text{ V}$	83			74			dB
Supply-voltage rejection	$-0.2 \text{ V} \geq V^- \geq -5.4 \text{ V}$	86	96		80	96		dB
	$V^+ = 1.0 \text{ V}$ (1.2V)	80			74			dB
	1.0 V (1.1V) $\leq V^+ \leq 6.3 \text{ V}$	94	106		80	106		dB
	$V^- = 0.2 \text{ V}$	88			74			dB
Offset voltage drift			2.0			5.0		μV/°C
Offset current drift			2.0			5.0		pA/°C
Bias current drift			60			90		pA/°C
Line regulation	1.2 V (1.3V) $\leq V_S \leq 6.5 \text{ V}$		0.001	0.01		0.001	0.02	%/V
	$0 \leq I_{\text{REF}} \leq 0.5 \text{ mA}$, $V_{\text{REF}} = 200 \text{ mV}$			0.02			0.03	%/V
Load regulation	$0 \leq I_{\text{REF}} \leq 0.5 \text{ mA}$		0.01	0.1		0.01	0.15	%
	$V^+ - V_{\text{REF}} \geq 1.0 \text{ V}$ (1.1V)			0.15			0.2	%

Electrical Characteristics (Continued)

$T_J=25^\circ\text{C}$, $T_{\text{MIN}} \leq T_J \leq T_{\text{MAX}}$ (Boldface type refers to limits over temperature range) (Note 5)

Parameter	Conditions	LM10BL			LM10CL			Units
		Min	Typ	Max	Min	Typ	Max	
Amplifier gain	$0.2\text{V} \leq V_{\text{REF}} \leq 5.5\text{V}$	30 20	70		20 15	70		V/mV V/mV
Feedback sense voltage		195 194	200	205 206	190 189	200	210 211	mV mV
Feedback current			20	50 65		22	75 90	nA nA
Reference drift			0.002			0.003		%/°C
Supply current			260	400 500		280	500 570	μA μA

Note 1: Absolute Maximum Ratings indicate limits beyond which damage to the device may occur. Operating Ratings indicate conditions for which the device is functional, but do not guarantee specific performance limits.

Note 2: The Input voltage can exceed the supply voltages provided that the voltage from the input to any other terminal does not exceed the maximum differential input voltage and excess dissipation is accounted for when $V_{\text{IN}} < V^-$.

Note 3: The maximum, operating-junction temperature is 150°C for the LM10, 100°C for the LM10B(L) and 85°C for the LM10C(L). At elevated temperatures, devices must be derated based on package thermal resistance.

Note 4: Internal thermal limiting prevents excessive heating that could result in sudden failure, but the IC can be subjected to accelerated stress with a shorted output and worst-case conditions.

Note 5: These specifications apply for $V^- \leq V_{\text{CM}} \leq V^+ - 0.85\text{V}$ (**1.0V**), 1.2V (**1.3V**) $< V_S \leq V_{\text{MAX}}$, $V_{\text{REF}} = 0.2\text{V}$ and $0 \leq I_{\text{REF}} \leq 1.0\text{mA}$, unless otherwise specified: $V_{\text{MAX}} = 40\text{V}$ for the standard part and 6.5V for the low voltage part. Normal typeface indicates 25°C limits. **Boldface type indicates limits and altered test conditions for full-temperature-range operation**; this is -55°C to 125°C for the LM10, -25°C to 85°C for the LM10B(L) and 0°C to 70°C for the LM10C(L). The specifications do not include the effects of thermal gradients ($\tau_1 \approx 20\text{ms}$), die heating ($\tau_2 \approx 0.2\text{s}$) or package heating. Gradient effects are small and tend to offset the electrical error (see curves).

Note 6: For $T_J > 90^\circ\text{C}$, I_{OS} may exceed 1.5nA for $V_{\text{CM}} = V^-$. With $T_J = 125^\circ\text{C}$ and $V^- \leq V_{\text{CM}} \leq V^- + 0.1\text{V}$, $I_{\text{OS}} \leq 5\text{nA}$.

Note 7: This defines operation in floating applications such as the bootstrapped regulator or two-wire transmitter. Output is connected to the V^+ terminal of the IC and input common mode is referred to V^- (see typical applications). Effect of larger output-voltage swings with higher load resistance can be accounted for by adding the positive-supply rejection error.

Note 8: Refer to RETS10X for LM10H military specifications.

Definition of Terms

Input offset voltage: That voltage which must be applied between the input terminals to bias the unloaded output in the linear region.

Input offset current: The difference in the currents at the input terminals when the unloaded output is in the linear region.

Input bias current: The absolute value of the average of the two input currents.

Input resistance: The ratio of the change in input voltage to the change in input current on either input with the other grounded.

Large signal voltage gain: The ratio of the specified output voltage swing to the change in differential input voltage required to produce it.

Shunt gain: The ratio of the specified output voltage swing to the change in differential input voltage required to produce it with the output tied to the V^+ terminal of the IC. The load and power source are connected between the V^+ and V^- terminals, and input common-mode is referred to the V^- terminal.

Common-mode rejection: The ratio of the input voltage range to the change in offset voltage between the extremes.

Supply-voltage rejection: The ratio of the specified supply-voltage change to the change in offset voltage between the extremes.

Line regulation: The average change in reference output voltage over the specified supply voltage range.

Load regulation: The change in reference output voltage from no load to that load specified.

Feedback sense voltage: The voltage, referred to V^- , on the reference feedback terminal while operating in regulation.

Reference amplifier gain: The ratio of the specified reference output change to the change in feedback sense voltage required to produce it.

Feedback current: The absolute value of the current at the feedback terminal when operating in regulation.

Supply current: The current required from the power source to operate the amplifier and reference with their outputs unloaded and operating in the linear range.

Typical Performance Characteristics (Op Amp)

Input Current

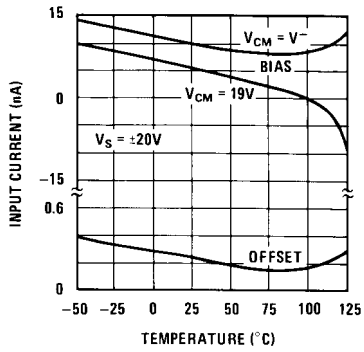

DS005652-18

Common Mode Limits

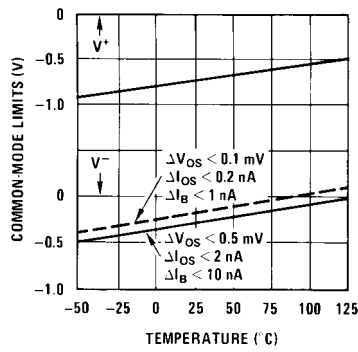

DS005652-19

Output Voltage Drift

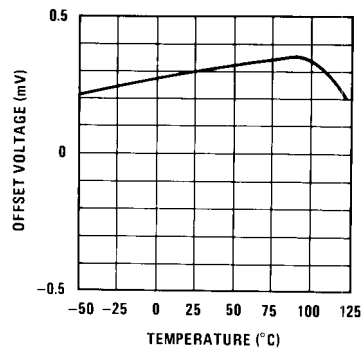

DS005652-20

Input Noise Voltage

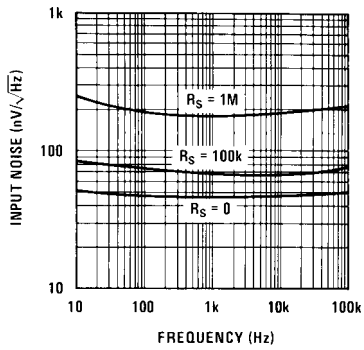

DS005652-21

DC Voltage Gain

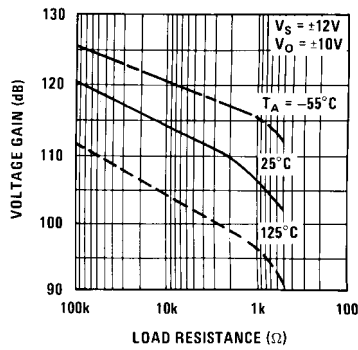

DS005652-22

Transconductance

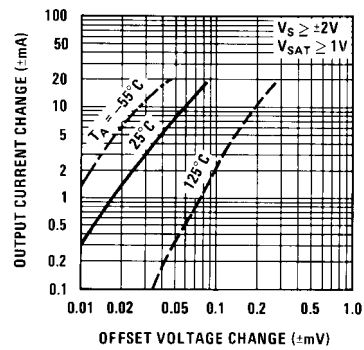

DS005652-23

Output Saturation Characteristics

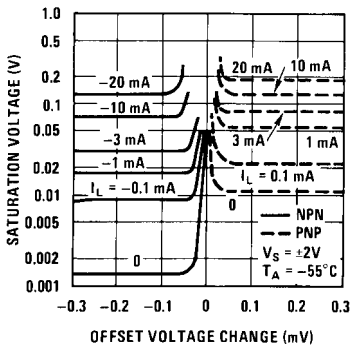

DS005652-24

Output Saturation Characteristics

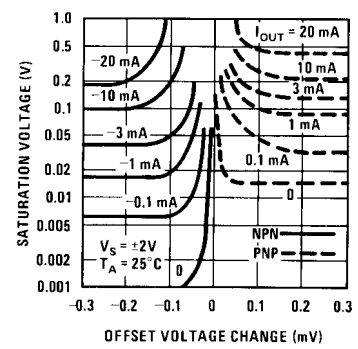

DS005652-25

Output Saturation Characteristics

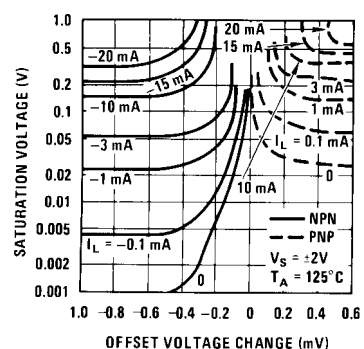

DS005652-26

Typical Performance Characteristics (Op Amp) (Continued)

Minimum Supply Voltage

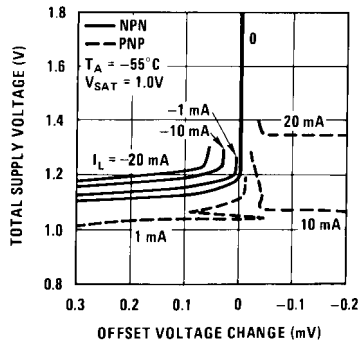

DS005652-27

Minimum Supply Voltage

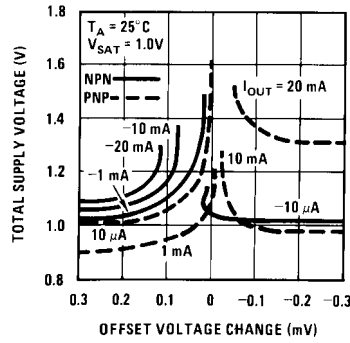

DS005652-28

Minimum Supply Voltage

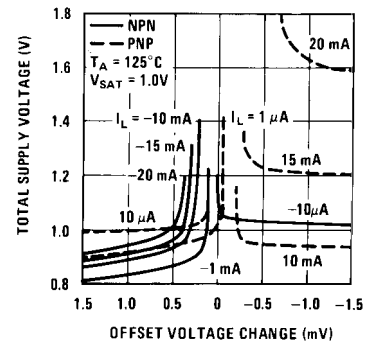

DS005652-29

Frequency Response

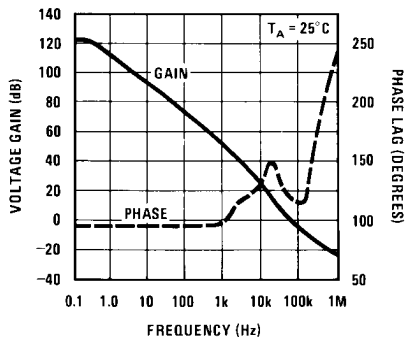

DS005652-30

Output Impedance

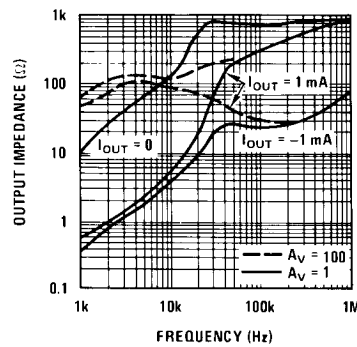

DS005652-31

Typical Stability Range

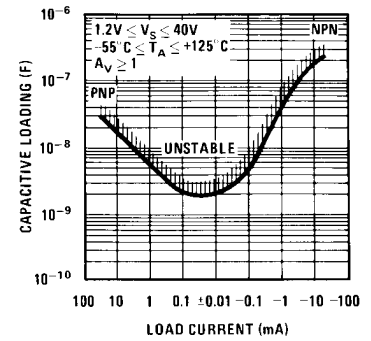

DS005652-32

Large Signal Response

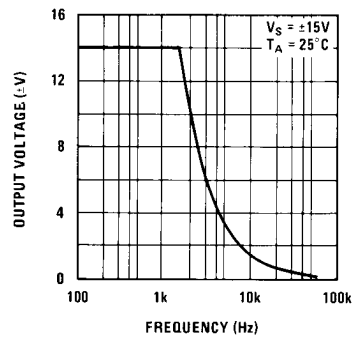

DS005652-33

Comparator Response Time For Various Input Overdrives

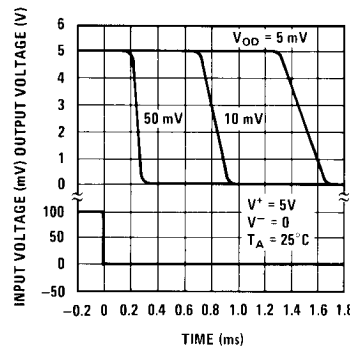

DS005652-34

Comparator Response Time For Various Input Overdrives

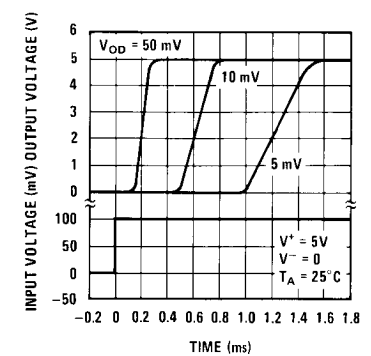

DS005652-35

Typical Performance Characteristics (Op Amp) (Continued)

Follower Pulse Response

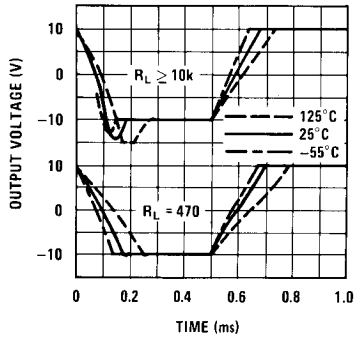

DS005652-36

Noise Rejection

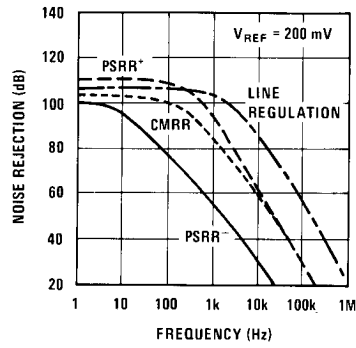

DS005652-37

Rejection Slow Limiting

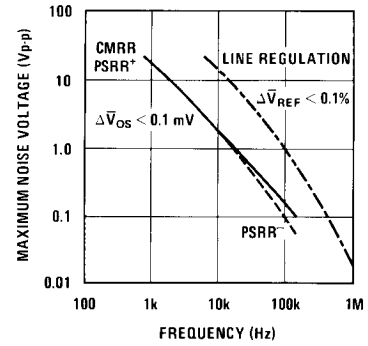

DS005652-38

Supply Current

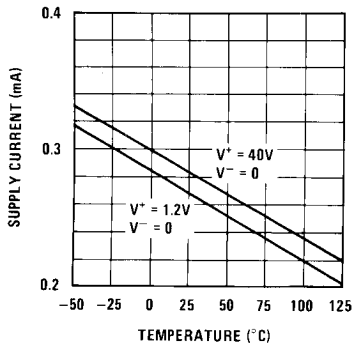

DS005652-39

Thermal Gradient Feedback

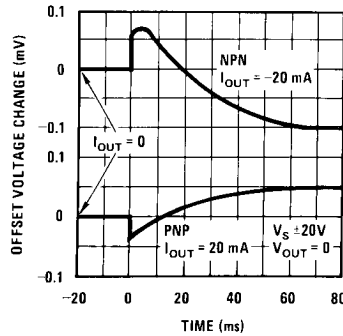

DS005652-40

Thermal Gradient Cross-coupling

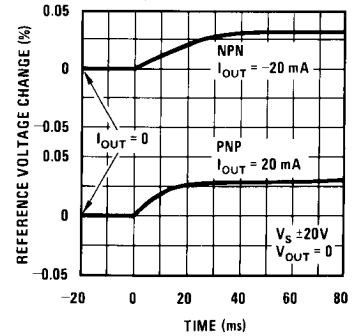

DS005652-41

Shunt Gain

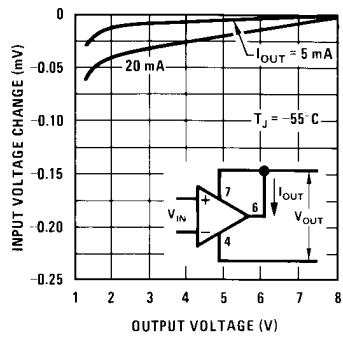

DS005652-42

Shunt Gain

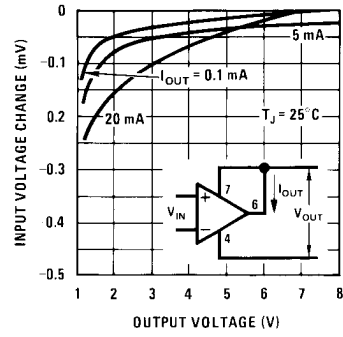

DS005652-43

Shunt Gain

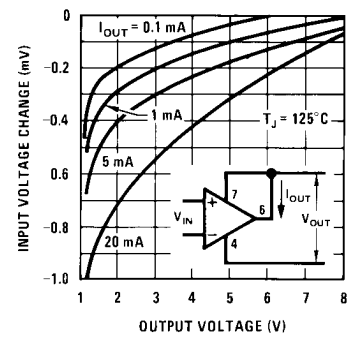

DS005652-44

Typical Performance Characteristics (Reference)

Line Regulation

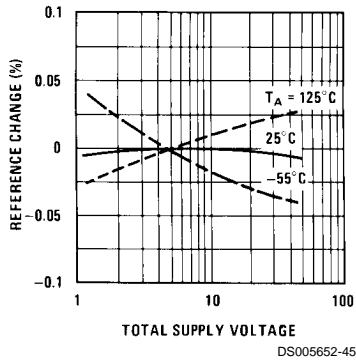

DS005652-45

Load Regulation

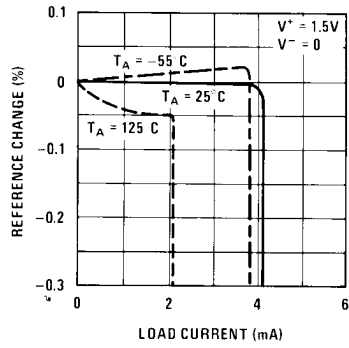

DS005652-46

Reference Noise Voltage

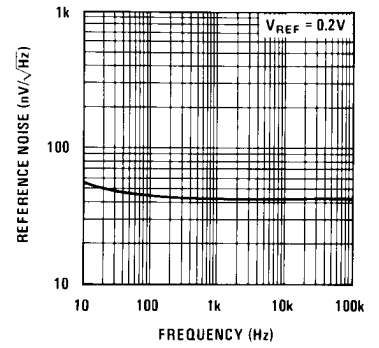

DS005652-47

Minimum Supply Voltage

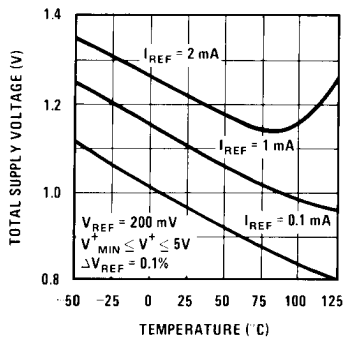

DS005652-48

Output Saturation

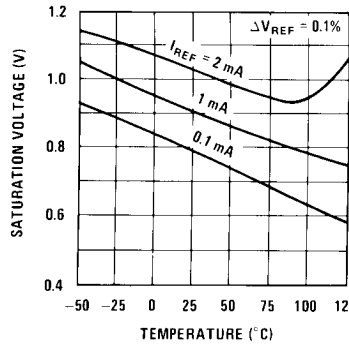

DS005652-49

Typical Stability Range

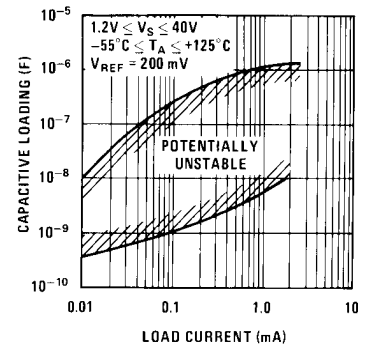

DS005652-50

Typical Applications (Note 10) (Pin numbers are for devices in 8-pin packages)

Op Amp Offset Adjustment

Standard

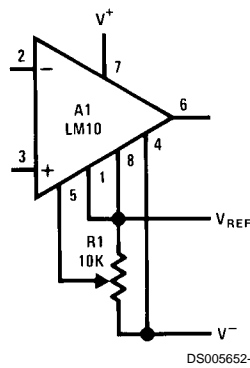

DS005652-51

Limited Range

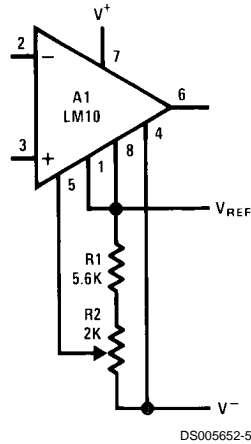

DS005652-52

Limited Range With Boosted Reference

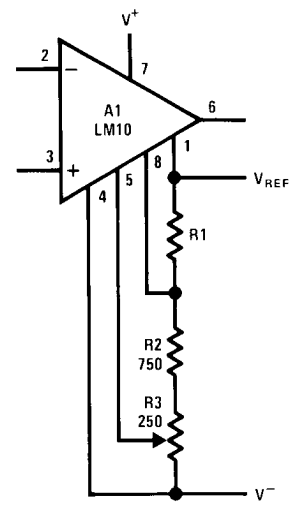

DS005652-53

Typical Applications (Note 10) (Pin numbers are for devices in 8-pin packages) (Continued)

Positive Regulators (Note 9)

Low Voltage

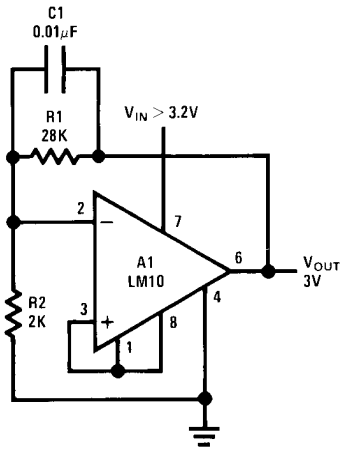

DS005652-54

Best Regulation

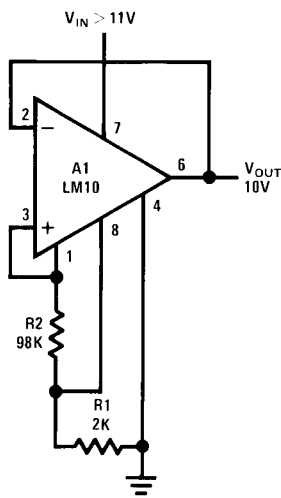

DS005652-55

Zero Output

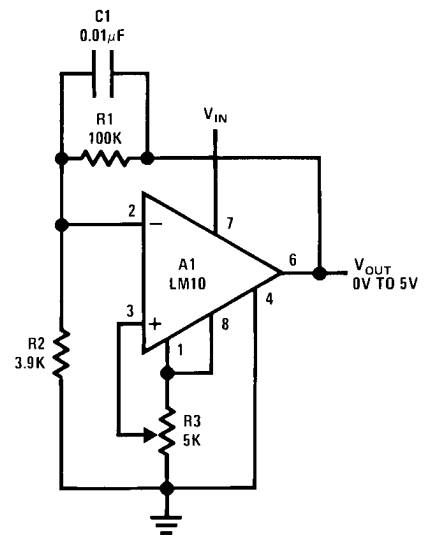

DS005652-56

Note 9: Use only electrolytic output capacitors.

Current Regulator

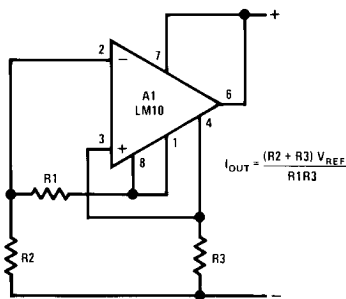

DS005652-57

Shunt Regulator

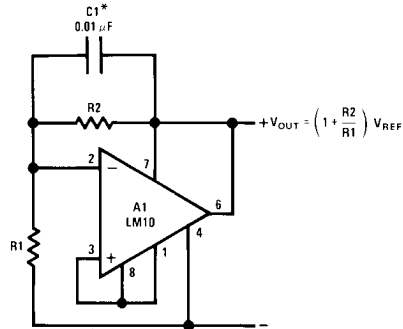

DS005652-58

Required For Capacitive Loading

Negative Regulator

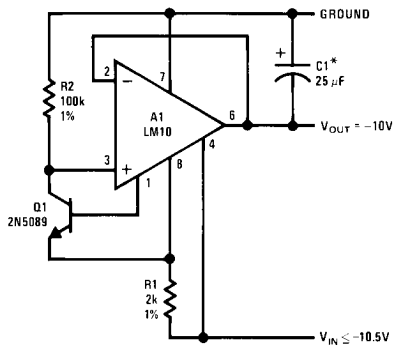

DS005652-59

*Electrolytic

Precision Regulator

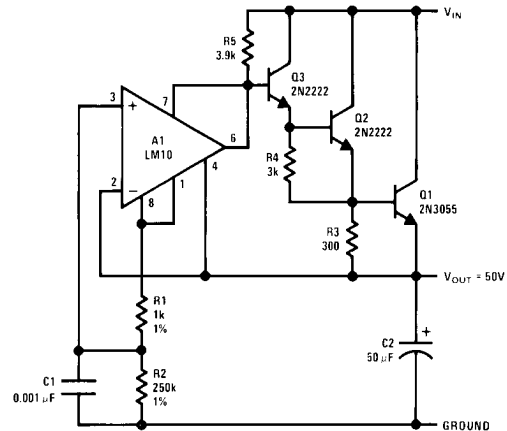

DS005652-60

Typical Applications (Note 10) (Pin numbers are for devices in 8-pin packages) (Continued)

Laboratory Power Supply

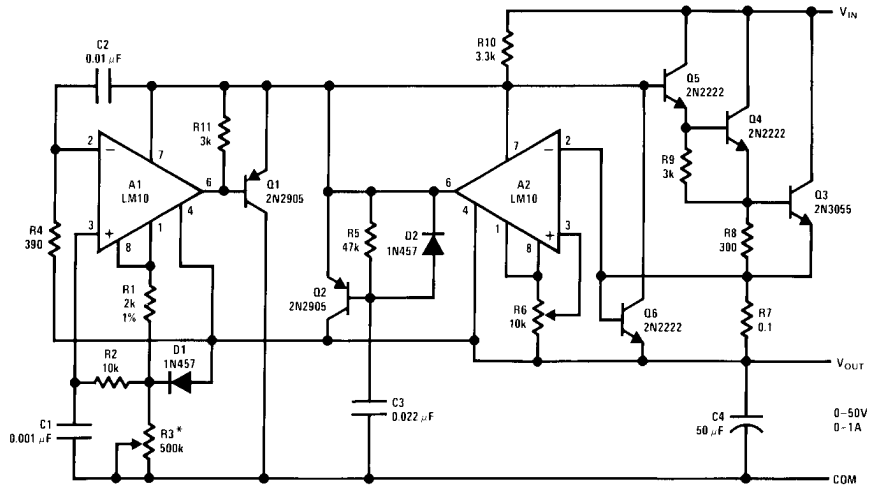

DS005652-61

$V_{OUT} = 10^{-4} R_3$

HV Regulator

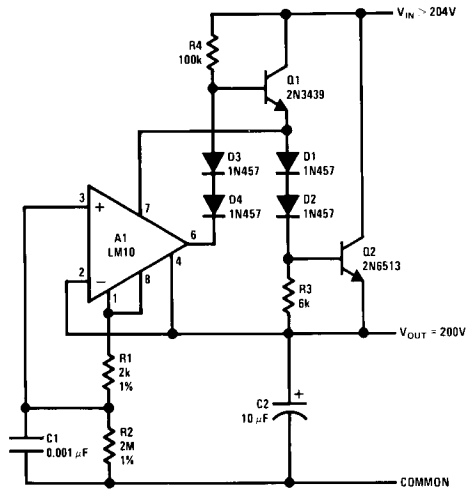

DS005652-62

$$V_{OUT} = \frac{R_2}{R_1} V_{REF}$$

DS005652-84

Typical Applications (Note 10) (Pin numbers are for devices in 8-pin packages) (Continued)

Protected HV Regulator

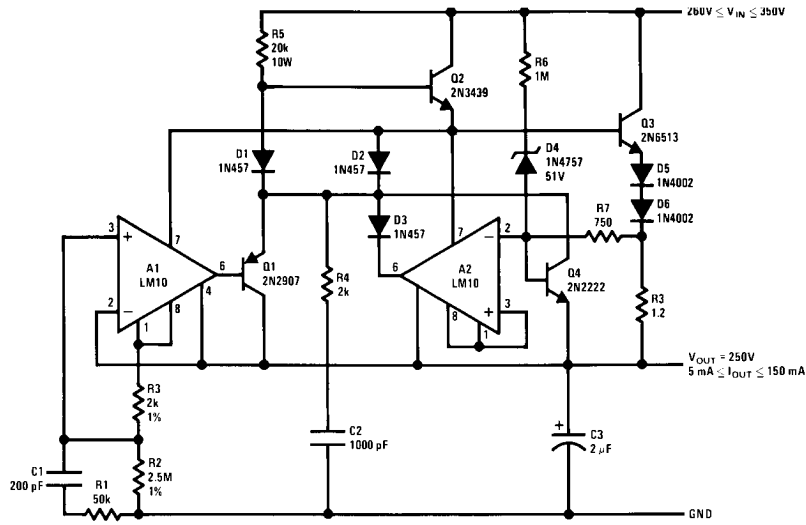

DS005652-63

Flame Detector

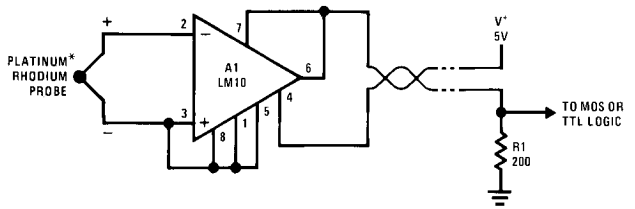

DS005652-64

*800°C Threshold Is Established By Connecting Balance To VREF.

Light Level Sensor

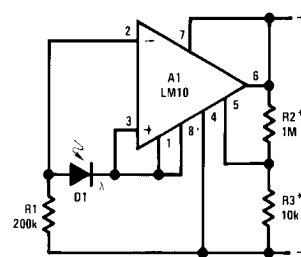

DS005652-65

*Provides Hysteresis

Remote Amplifier

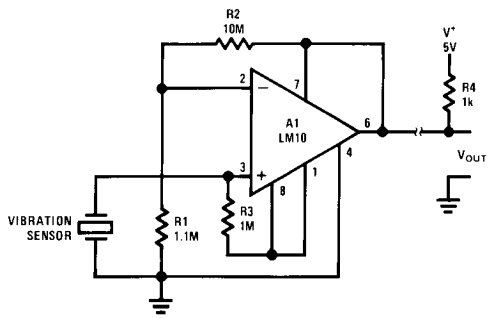

DS005652-66

Remote Thermocouple Amplifier

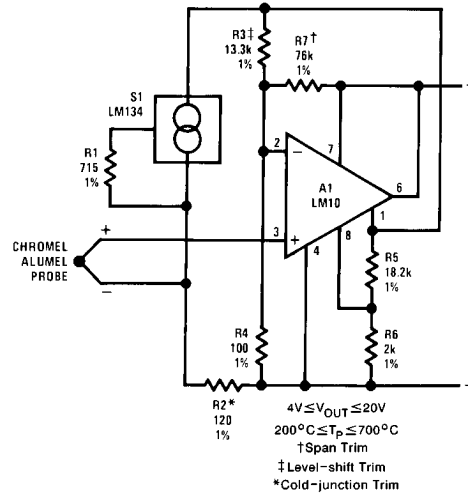

DS005652-67

Typical Applications (Note 10) (Pin numbers are for devices in 8-pin packages) (Continued)

Transmitter for Bridge Sensor

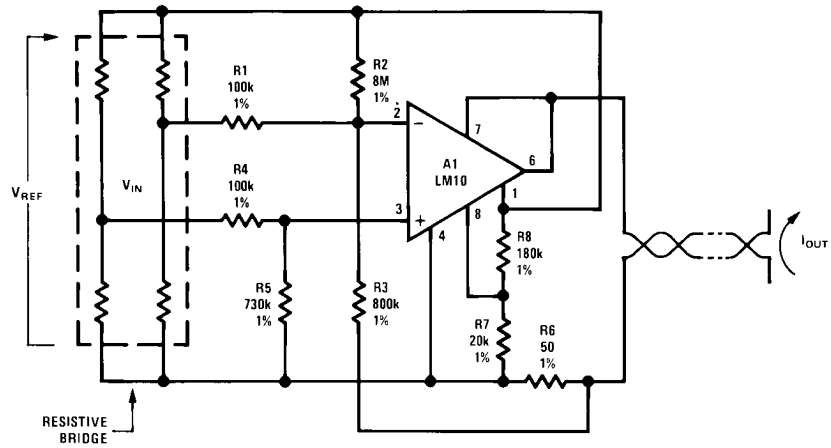

DS005652-68

Precision Thermocouple Transmitter

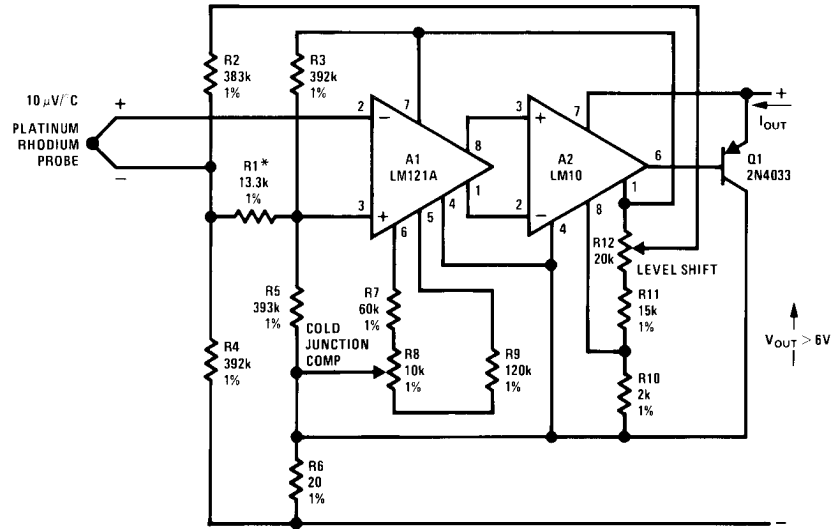

DS005652-69

10 mA ≤ I_{OUT} ≤ 50 mA
 500°C ≤ T_P ≤ 1500°C
 *Gain Trim

Typical Applications (Note 10) (Pin numbers are for devices in 8-pin packages) (Continued)

Resistance Thermometer Transmitter

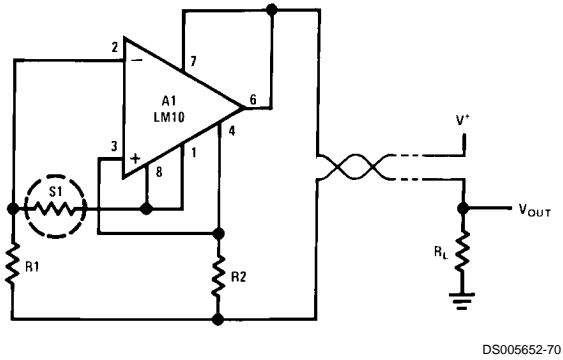

DS005652-70

Optical Pyrometer

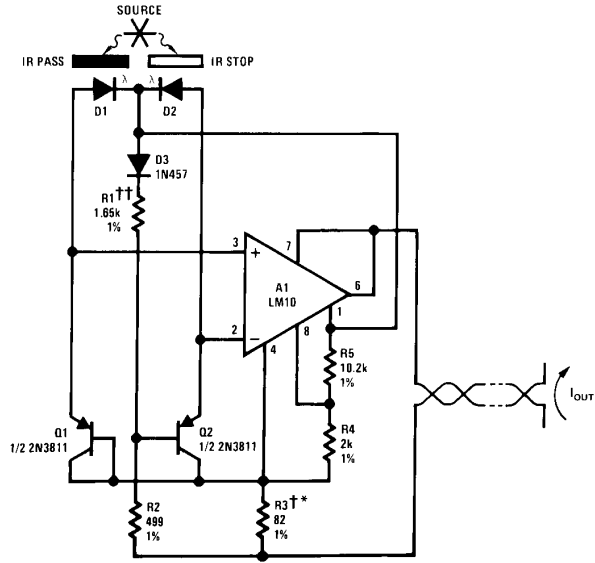

DS005652-71

††Level-shift Trim
 *Scale Factor Trim
 †Copper Wire Wound

$$1 \text{ mA} \leq I_{OUT} \leq 5 \text{ mA}$$

$$0.01 \leq \frac{I_{D2}}{I_{D1}} \leq 100$$

Thermocouple Transmitter

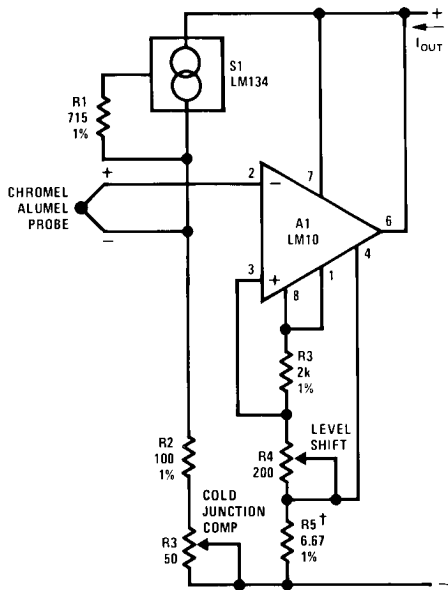

DS005652-72

$200^{\circ}\text{C} \leq T_p \leq 700^{\circ}\text{C}$
 $1 \text{ mA} \leq I_{OUT} \leq 5 \text{ mA}$
 †Gain Trim

Logarithmic Light Sensor

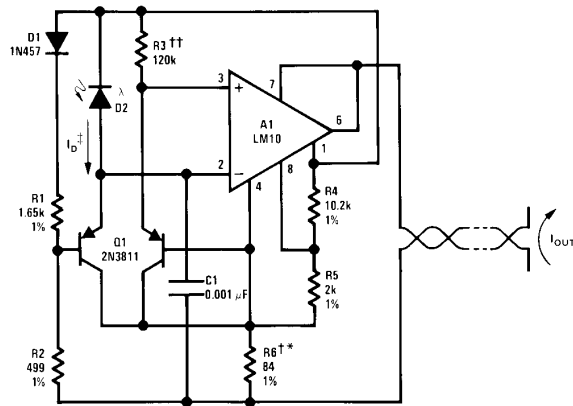

DS005652-73

$1 \text{ mA} \leq I_{OUT} \leq 5 \text{ mA}$
 $\pm 50 \mu\text{A} \leq I_D \leq 500 \mu\text{A}$
 ††Center Scale Trim
 †Scale Factor Trim
 *Copper Wire Wound

Typical Applications (Note 10) (Pin numbers are for devices in 8-pin packages) (Continued)

Battery-level Indicator

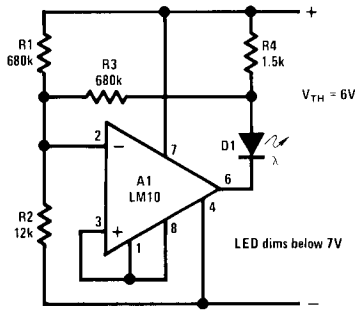

DS005652-74

Battery-threshold Indicator

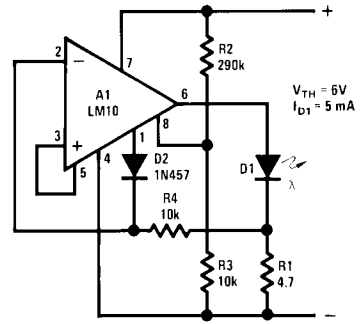

DS005652-75

Single-cell Voltage Monitor

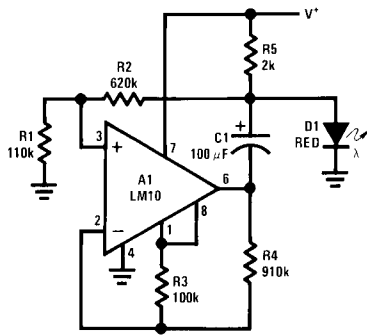

DS005652-76

Flashes Above 1.2V
Rate Increases With
Voltage

Double-ended Voltage Monitor

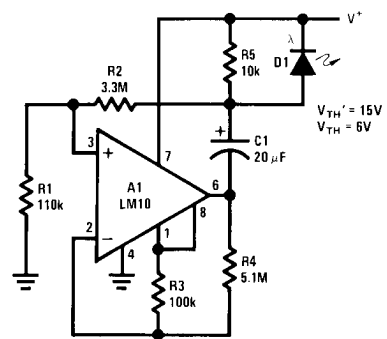

DS005652-77

Flash Rate Increases
Above 6V and Below 15V

Meter Amplifier

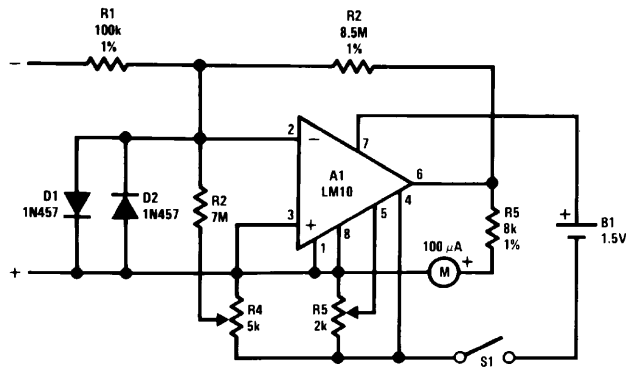

DS005652-78

INPUT
10 mV, 100nA
FULL-SCALE

Typical Applications (Note 10) (Pin numbers are for devices in 8-pin packages) (Continued)

Thermometer

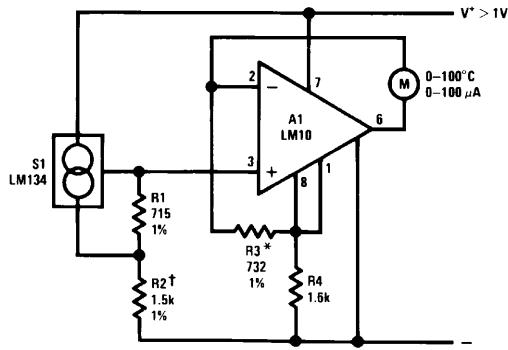

DS005652-79

*Trim For Span
 †Trim For Zero

Light Meter

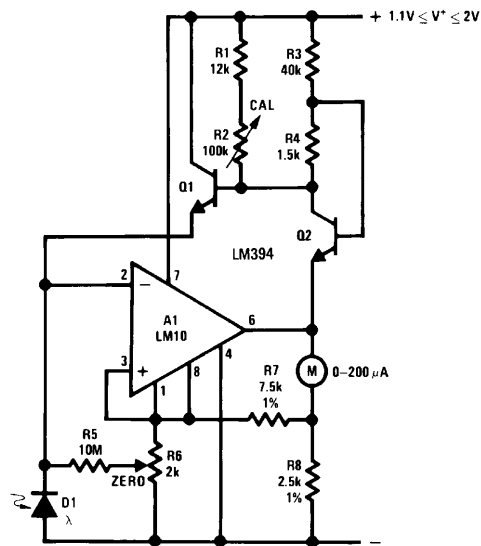

DS005652-80

$1 \leq \lambda/\lambda_0 \leq 10^5$

Typical Applications (Note 10) (Pin numbers are for devices in 8-pin packages) (Continued)

Microphone Amplifier

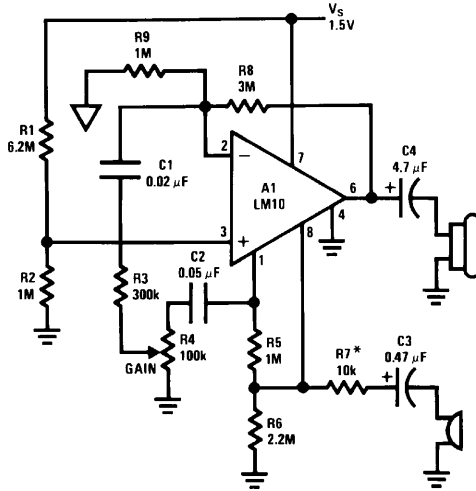

DS005652-81

Z_{OUT} —680Ω @ 5 kHz
 A_V ≤1k
 f_1 —100 Hz
 f_2 —5 kHz
 R_L —500
 *Max Gain Trim

Isolated Voltage Sensor

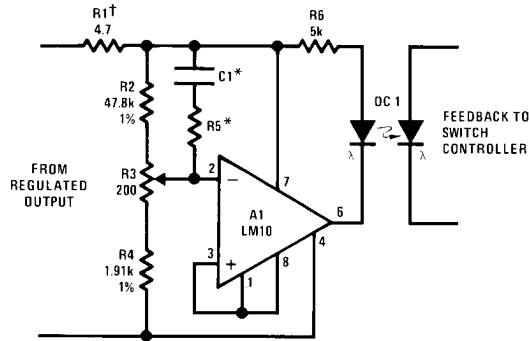

DS005652-82

†Controls "Loop Gain"
 *Optional Frequency Shaping

Typical Applications (Note 10) (Pin numbers are for devices in 8-pin packages) (Continued)

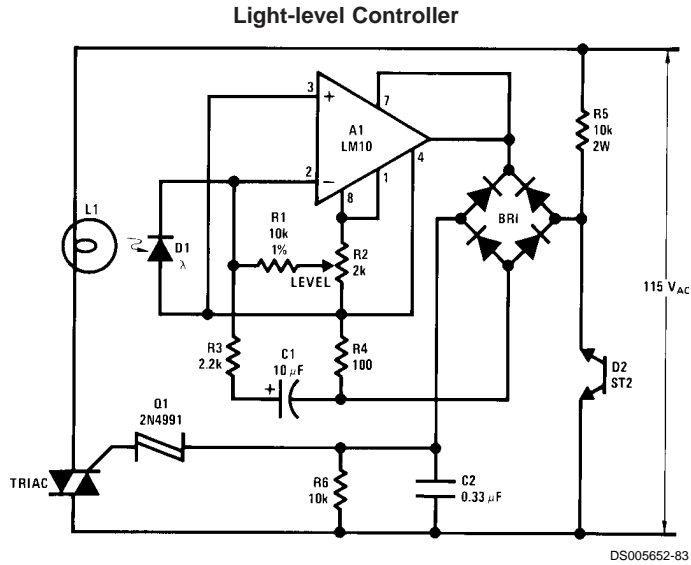

Note 10: Circuit descriptions available in application note AN-211.

Application Hints

With heavy amplifier loading to V^- , resistance drops in the V^- lead can adversely affect reference regulation. Lead resistance can approach 1Ω . Therefore, the common to the reference circuitry should be connected as close as possible to the package.

Operational Amplifier Schematic (Pin numbers are for 8-pin packages)

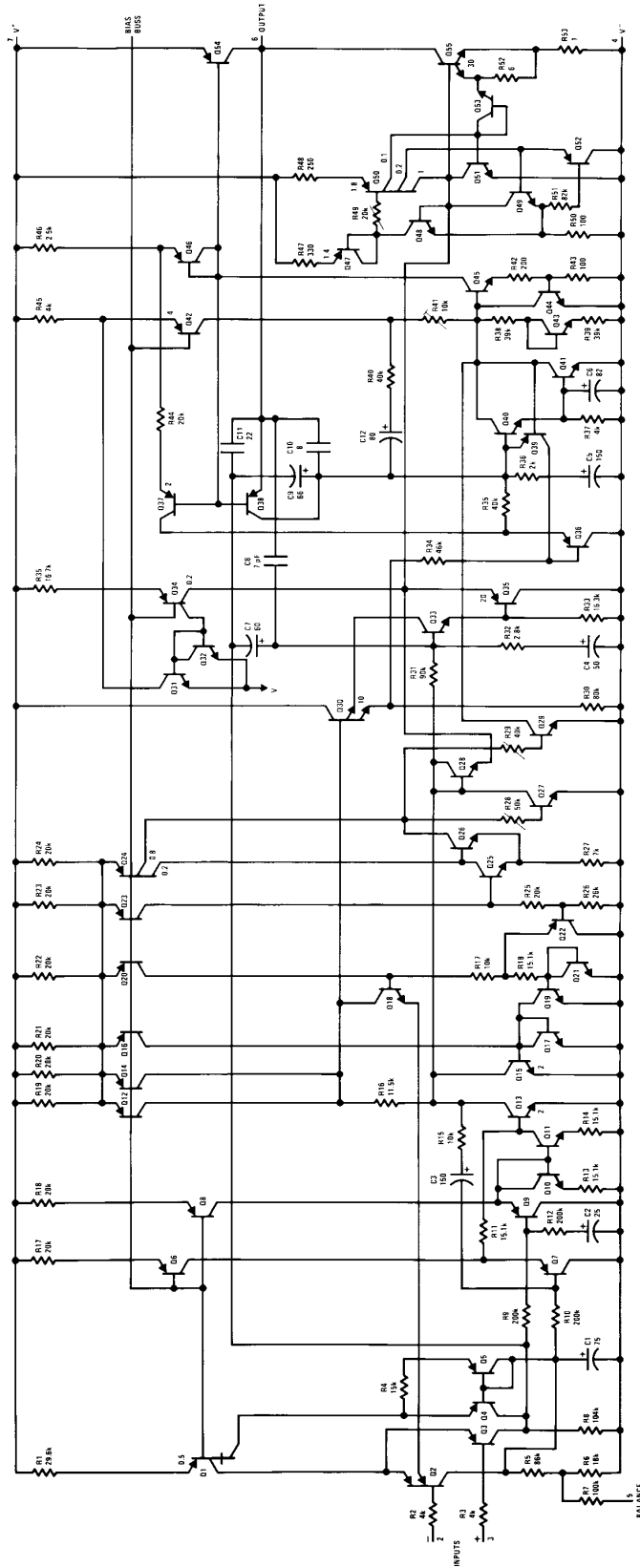

DS006652-13

Reference and Internal Regulator (Pin numbers are for 8-pin packages)

LM10

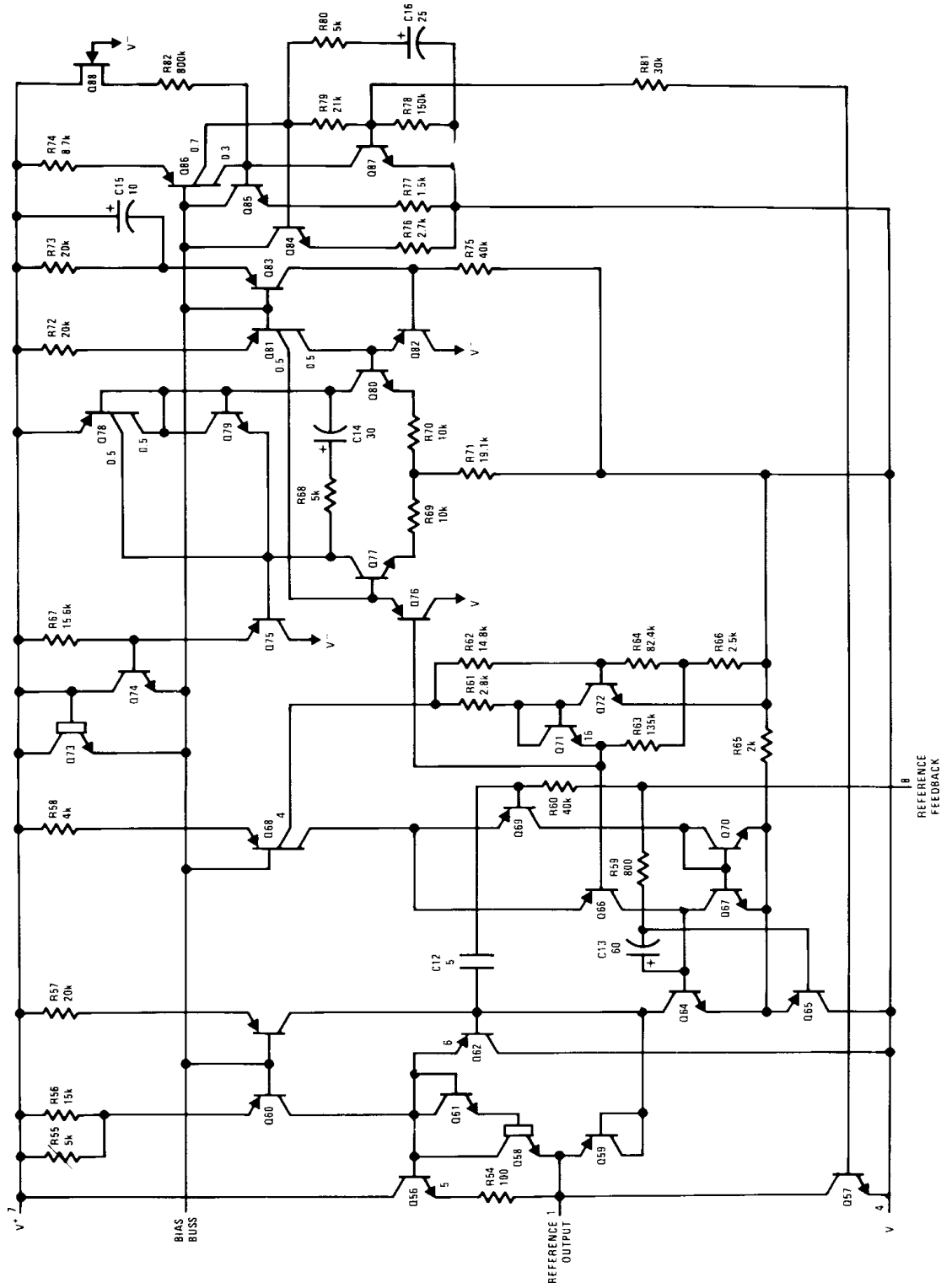

DS000662-14

Physical Dimensions inches (millimeters) unless otherwise noted

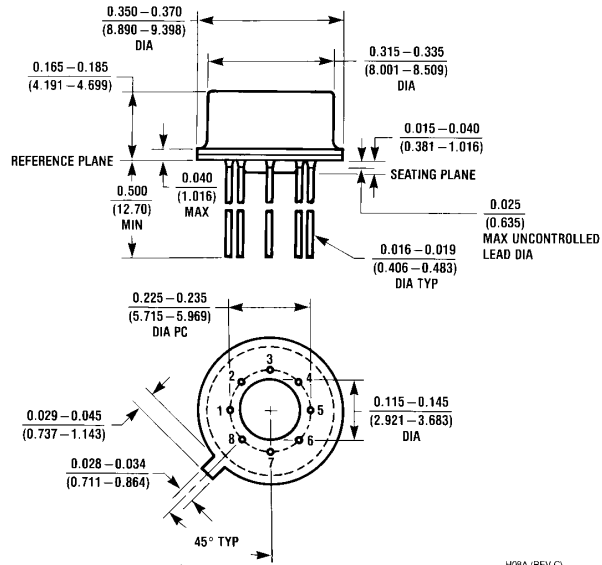

H08A (REV C)

Metal Can Package (H)
Order Number LM10BH, LM10CH, LM10CLH or LM10H/883
NS Package Number H08A

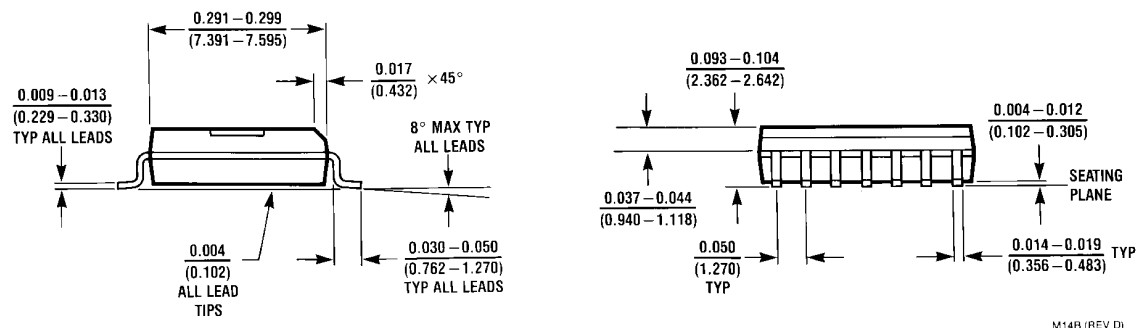
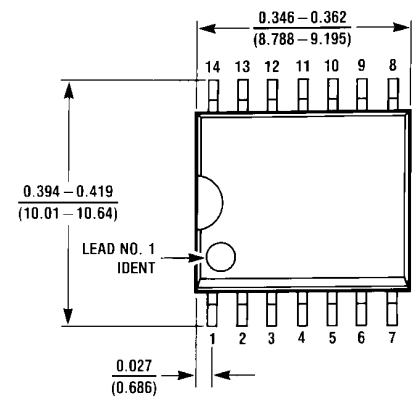

M14B (REV D)

S.O. Package (WM)
Order Number LM10CWM or LM10CWMX
NS Package Number M14B

Physical Dimensions inches (millimeters) unless otherwise noted (Continued)

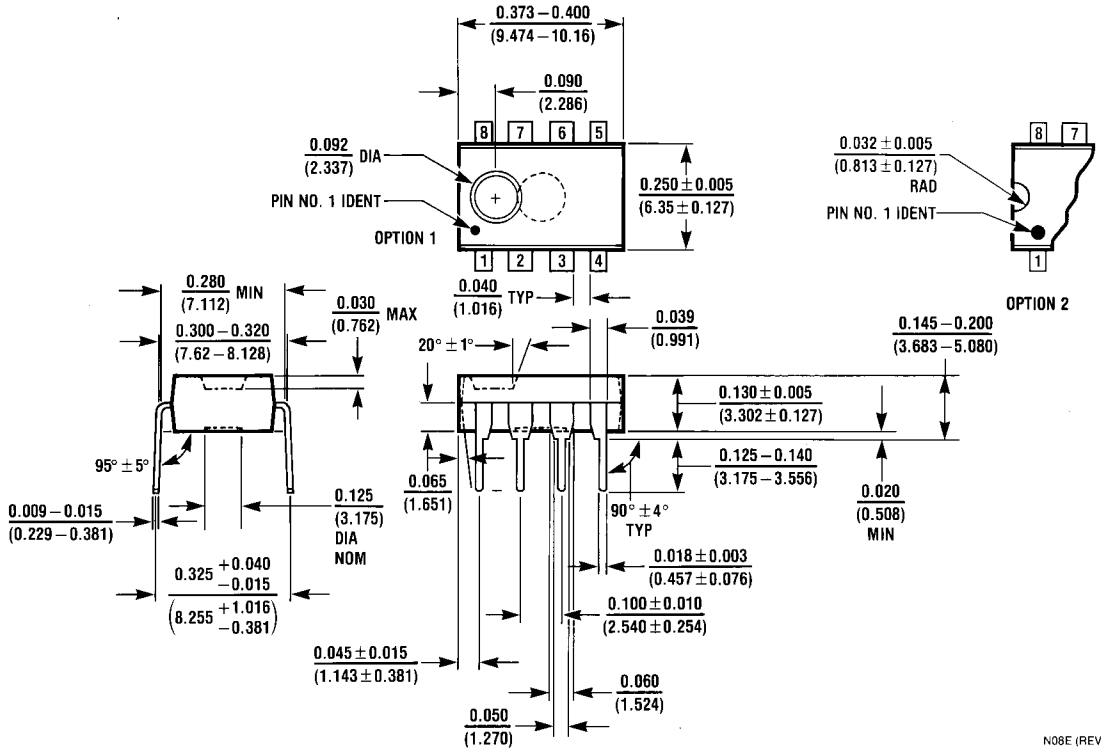

Dual-In-Line Package (N)
Order Number LM10CN or LM10CLN
NS Package Number N08E

LIFE SUPPORT POLICY

NATIONAL'S PRODUCTS ARE NOT AUTHORIZED FOR USE AS CRITICAL COMPONENTS IN LIFE SUPPORT DEVICES OR SYSTEMS WITHOUT THE EXPRESS WRITTEN APPROVAL OF THE PRESIDENT AND GENERAL COUNSEL OF NATIONAL SEMICONDUCTOR CORPORATION. As used herein:

1. Life support devices or systems are devices or systems which, (a) are intended for surgical implant into the body, or (b) support or sustain life, and whose failure to perform when properly used in accordance with instructions for use provided in the labeling, can be reasonably expected to result in a significant injury to the user.
2. A critical component is any component of a life support device or system whose failure to perform can be reasonably expected to cause the failure of the life support device or system, or to affect its safety or effectiveness.



National Semiconductor Corporation
Americas
Tel: 1-800-272-9959
Fax: 1-800-737-7018
Email: support@nsc.com
www.national.com

National Semiconductor Europe
Fax: +49 (0) 180-530 85 86
Email: europe.support@nsc.com
Deutsch Tel: +49 (0) 69 9508 6208
English Tel: +44 (0) 870 24 0 2171
Français Tel: +33 (0) 1 41 91 8790

National Semiconductor Asia Pacific Customer Response Group
Tel: 65-2544466
Fax: 65-2504466
Email: ap.support@nsc.com

National Semiconductor Japan Ltd.
Tel: 81-3-5639-7560
Fax: 81-3-5639-7507

See A/D Converters Products

[Products](#) > [Analog - Amplifiers](#) > [Operational Amplifiers](#) > [Low Power](#) > LM10

LM10 Product Folder

Operational Amplifier and Voltage Reference

[General Description](#)

[Features](#)

[Datasheet](#)

[Package & Models](#)

[Samples & Pricing](#)

[Design Tools](#)

[Application Notes](#)

Parametric Table

Channels (Channels)	1
Input Output Type	Vcm to V-, R-R Out
Bandwidth, typ (MHz)	.09, .05
Slew Rate, typ (Volts/usec)	.20
Supply Current per Channel, typ (mA)	.30, .28, .27
Minimum Supply Voltage (Volt)	1.10

Parametric Table

Maximum Supply Voltage (Volt)	40, 7
Offset Voltage, Max (mV)	4, 2
Input Bias Current, Temp Max (nA)	40, 30
Output Current, typ (mA)	20
Voltage Noise, typ (nV/Hz)	50
Shut down	No
Special Features	w/Reference

Datasheet

Title	Size in Kbytes	Date	View Online	Download	Receive via Email
LM10 Operational Amplifier and Voltage Reference	687 Kbytes	22-Aug-00	View Online	Download	Receive via Email
LM10 Operational Amplifier and Voltage Reference (JAPANESE)	655 Kbytes		View Online	Download	Receive via Email
LM10 Mil-Aero Datasheet MNLM10-X	12 Kbytes		View Online	Download	Receive via Email

If you have trouble printing or viewing PDF file(s), see [Printing Problems](#).

Package Availability, Models, Samples & Pricing

Part Number	Package			Status	Models		Samples & Electronic Orders	Budgetary Pricing		Std Pack Size	Package Marking
	Type	Pins	MSL		SPICE	IBIS		Qty	\$US each		
LM10CWM	SOIC WIDE	14	MSL	Full production	N/A	N/A	24 Hour Buy Now	1K+	\$1.6500	rail of 50	[logo]UçZç2çT LM10CWM

LM10CWMX	SOIC WIDE	14	MSL	Full production	N/A	N/A	Buy Now	1K+	\$1.6500	reel of 1000	[logo] UçZç2çT LM10CWM
LM10CLN	MDIP	8	MSL	Full production	N/A	N/A	Buy Now	1K+	\$1.3000	rail of 40	[logo] UçZç2çT LM10CLN
LM10CN	MDIP	8	MSL	Full production	N/A	N/A	Buy Now	1K+	\$1.6500	rail of 40	[logo] UçZç2çT LM10CN
LM10BH	TO-5	8	MSL	Full production	N/A	N/A	Buy Now	250+	\$11.8000	box of 500	[logo] çZç2çT LM10BH
LM10CH	TO-5	8	MSL	Full production	N/A	N/A	Buy Now	1K+	\$3.0400	box of 500	[logo] çZç2çT LM10CH
LM10CLH	TO-5	8	MSL	Full production	N/A	N/A	Buy Now	1K+	\$3.1200	box of 500	[logo] çZç2çT LM10CLH
5962-8760401GA	TO-5	8	MSL	Full production	N/A	N/A	Buy Now	50+	\$37.5000	tray of 20	[logo] çZçSç4çA LM10H/883QçM 5962-8760401GA \$E
LM10CL MDC	Die			Full production	N/A	N/A	Samples			tray of N/A	-
LM10CL MWC	Wafer			Full production	N/A	N/A				wafer jar of N/A	-
LM10 MD8	Die			Full production	N/A	N/A	Samples			tray of N/A	-
LM10 MW8	Wafer			Full production	N/A	N/A				wafer jar of N/A	-

General Description

The LM10 series are monolithic linear ICs consisting of a precision reference, an adjustable reference buffer and an independent, high quality op amp.

The unit can operate from a total supply voltage as low as 1.1V or as high as 40V, drawing only 270µA. A complementary output stage swings within 15 mV of the supply terminals or will deliver ±20 mA output current with ±0.4V saturation. Reference output can be as low as 200 mV.

The circuit is recommended for portable equipment and is completely specified for operation from a single power cell. In contrast, high output-drive capability, both voltage and current, along with thermal overload protection, suggest it in demanding general-purpose applications.

The device is capable of operating in a floating mode, independent of fixed supplies. It can function as a remote comparator, signal conditioner, SCR controller or transmitter for analog signals, delivering the processed signal on the same line used to supply power. It is also suited for operation in a wide range of voltage- and current-regulator applications, from low voltages to several hundred volts, providing greater precision than existing ICs.

This series is available in the three standard temperature ranges, with the commercial part having relaxed

limits. In addition, a low-voltage specification (suffix "L") is available in the limited temperature ranges at a cost savings.

Features

- input offset voltage: 2.0 mV (max)
- input offset current: 0.7 nA (max)
- input bias current: 20 nA (max)
- reference regulation: 0.1% (max)
- offset voltage drift: 2 μ V/ $^{\circ}$ C
- reference drift: 0.002%/ $^{\circ}$ C

Design Tools

Title	Size in Kbytes	Date	<input type="checkbox"/>	<input type="checkbox"/>	<input type="checkbox"/>
			View Online	Download	Receive via Email
Amplifiers Selection Guide software for Windows	7 Kbytes	12-Jun-2002	View		

If you have trouble printing or viewing PDF file(s), see [Printing Problems](#).

Application Notes

Title	Size in Kbytes	Date	<input type="checkbox"/>	<input type="checkbox"/>	<input type="checkbox"/>
			View Online	Download	Receive via Email
AN-211: New Op Amp Ideas	296 Kbytes	4-Nov-95	View Online	Download	Receive via Email
AN-242: Applying a New Precision Op Amp	267 Kbytes	4-Nov-95	View Online	Download	Receive via Email
AN-247: Using the ADC0808/ADC0809 8-Bit MicroP Compatible A/D Converters with 8-Channel Analog Multiplexer	287 Kbytes	4-Nov-95	View Online	Download	Receive via Email
AN-288: Application Note 288 System-Oriented DC-DC Conversion Techniques	405 Kbytes	1-May-98	View Online	Download	Receive via Email
AN-298: Isolation Techniques for Signal Conditioning	197 Kbytes	4-Nov-95	View Online	Download	Receive via Email
AN-299: Application Note 299 Audio Applications of Linear Integrated Circuits	232 Kbytes	24-Feb-99	View Online	Download	Receive via Email
AN-300: Simple Circuit Detects Loss of 4-20 mA Signal	105 Kbytes	4-Nov-95	View Online	Download	Receive via Email
AN-460: LM34/LM35 Precision Monolithic Temperature Sensors	190 Kbytes	4-Nov-95	View Online	Download	Receive via Email

LM34/LM35 Precision Monolithic Temperature Sensors (JAPANESE)	322 Kbytes		View Online	Download	Receive via
TB-02: Digital Noise Reduction Techniques for COMBO II	69 Kbytes	4-Nov-95	View Online	Download	Receive via Email

If you have trouble printing or viewing PDF file(s), see [Printing Problems](#).

[Information as of 5-Aug-2002]

Search

[Design](#)
 [Purchasing](#)
 [Quality](#)
 [Company](#)
 [Home](#)

[About Languages](#) .
 [Website Guide](#) .
 [About "Cookies"](#) .
 National is [QS 9000 Certified](#) .
 [Privacy/Security Statement](#) .
 [Contact Us](#) .
 [Site Terms & Conditions of Use](#) .
 Copyright 2002 © National Semiconductor Corporation .
 [My Preferences](#) .
 [Feedback](#)