

PART NUMBER	REV	FIRST USED
680749-1	B	122500-1
680749-2	A	565435-5

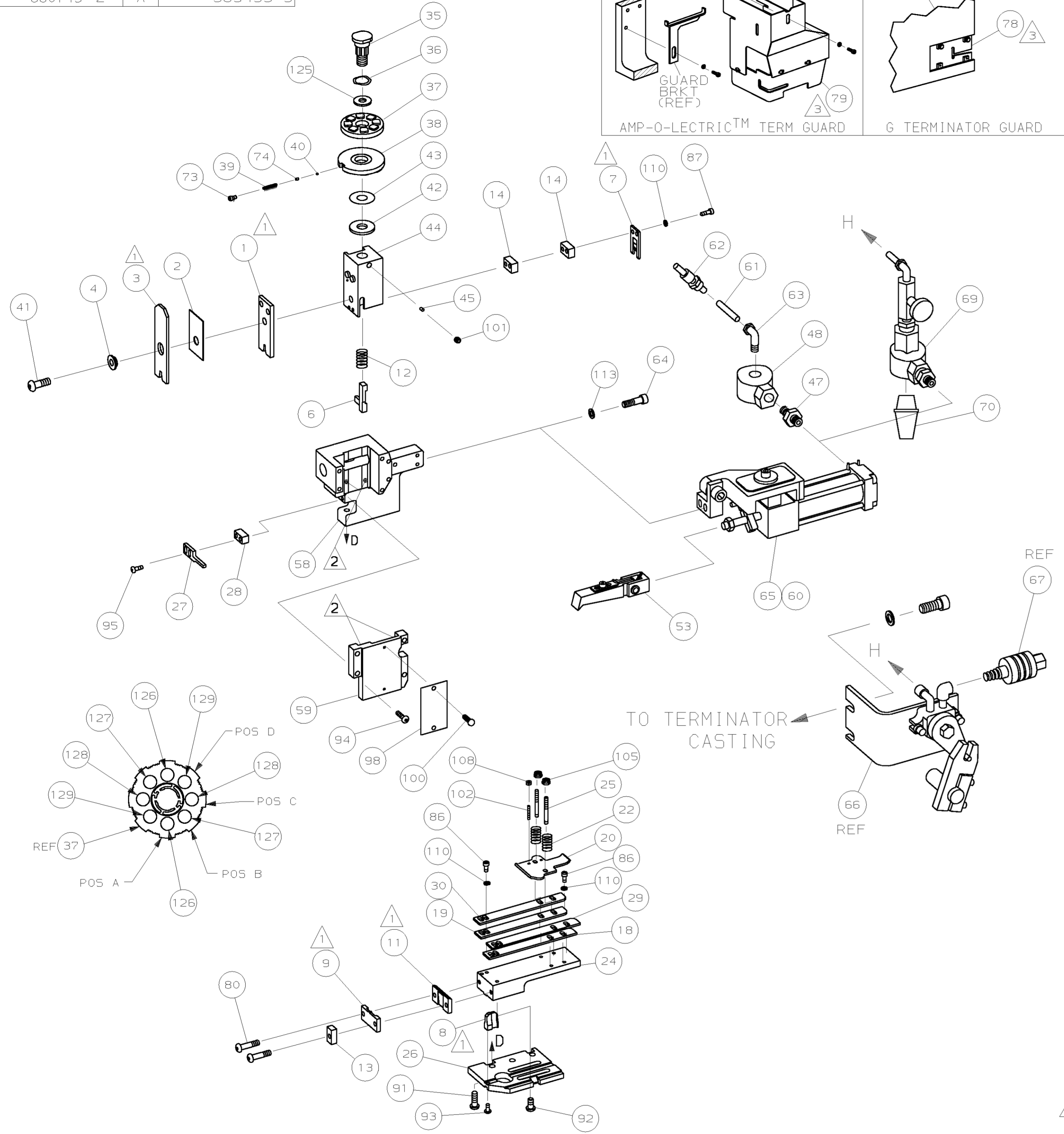
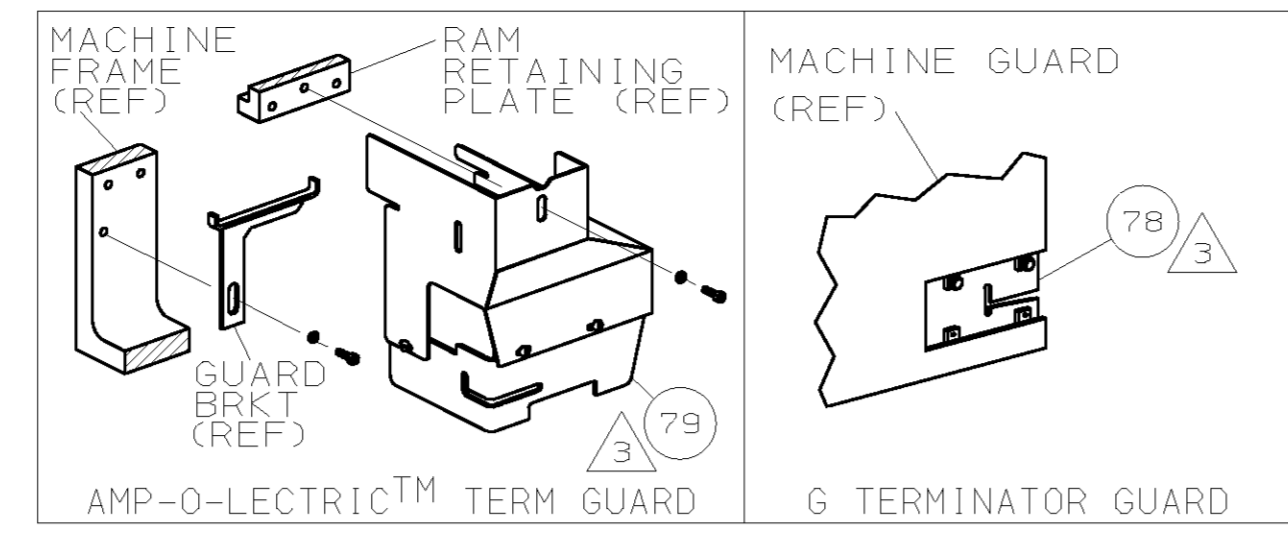

- ① RECOMMENDED SPARE PARTS.
- ② GREASE LIGHTLY.
- ③ GUARD MUST BE IN PLACE WHEN OPERATING APPLICATOR IN A BENCH MACHINE.
- ④ SEE DRAWING FOR COMPONENTS
- ⑤ ITEM 78 USED WITH G TERMINATOR ONLY.

TERMINAL NAME: RINGTONGUE		928911		CRIMP DATA (AMP TERMINAL)		
PAD LTR	CRIMP HEIGHT	WIRE SIZE	CRIMP	SIZE	TYPE	RANGE
A	.137 ±.002 [3.48 ±0.05mm]	6mm ²	WIRE	.180 [4.57mm]	F	4-6mm ²
B	.134 ±.002 [3.40 ±0.05mm]	5.5mm ²	INSUL	.250 [6.35mm]	F	∅4.6-5.3mm
C	.131 ±.002 [3.32 ±0.05mm]	5mm ²				
D	.124 ±.002 [3.16 ±0.05mm]	4mm ²				

QTY	REV	U/M	DWG SIZE	PART NO	DESCRIPTION	ITEM NO
2	2	-	C	2-354779-2	PIN, WIRE DISC (.3100)D	129
2	2	-	C	354779-9	PIN, WIRE DISC (.3035)C	128
2	2	-	C	9-354778-9	PIN, WIRE DISC (.2990)B	127
2	2	-	C	9-354778-1	PIN, WIRE DISC (.2950)A	126
1	1	-	A	986950-1	WASHER, FLAT PRECISION	125
1	1	-	A	217238-1	GENERAL INSTRUCTION PACKAGE	124
1	1	-	-	4088039	EF APPL INST 408-8039	123
						122
						121
						120
						119
						118
						117
						116
						115
						114
2	2	-	A	21024-5	WASHER, LOCK (#10) AIR ASSY	113
						112
						111
4	4	-	A	21024-4	WASHER, LOCK (NO.8) SHEAR BL	110
						109
2	2	-	A	21018-4	NUT, HEX (4-40) DRAG	108
						107
						106
2	2	-	A	21022-2	NUT, HEX SL (8-32) DRAG STUD	105
						104
						103
2	2	-	A	2-21006-6	SCR, SKT SET (4-40x.62) DRAG	102
1	1	-	A	21009-2	SCR, SKT SET (1/4-20x.25) RAM	101
2	2	-	A	21017-2	SCR, DRIVE (#2x.19) ID PLATE	100
						99
1	1	-	B	461264-1	PLATE, IDENTIFICATION	98
						97
						96
2	2	-	A	2-21002-2	SCR, BHC (8-32x.50) STRIPPER	95
4	4	-	A	2-21002-9	SCR, BHC (10-32x.75) CAP	94
1	1	-	A	22733-8	SCR, BHC (8-32x.38 LW) ANVIL	93
4	4	-	A	3-21002-3	SCR, BHC (1/4-20x.50) ST 6D PL	92
3	3	-	A	2-22733-8	SCR, BHC (1/4-20x.62) H5G	91
						90
						89
						88
2	2	-	A	2-21000-9	SCR, 5HC (8-32x.75) SLUG BLADE	87
4	4	-	A	2-21000-7	SCR, 5HC (8-32x.38) STRIP GUIDE	86
						85
						84
						83
						82
						81
2	2	-	A	3-21002-0	SCR, BHC (10-32x.88) SHEAR PL	80
1	-	-	A	455750-7	GUARD ASSY	79
-	REF	-	A	679532-1	INSERT, GUARD	78
						77
						76
						75
1	1	-	A	690603-1	SPRING, ASSIST	74
1	1	-	A	23030-1	SCR, SKT CAP (6-32x.25) CP DSC	73
						72
						71

QTY	REV	U/M	DWG SIZE	PART NO	DESCRIPTION	ITEM NO
-2	-1					

QTY	REV	U/M	DWG SIZE	PART NO	DESCRIPTION	ITEM NO	
-1					LEADMAKER & BENCH MODEL G		
-2					BENCH MODEL K		
					AIR FEED		
					AIR FEED		
④	1	-	-	A	25545-2	MUFFLER	70
④	1	-	-	C	692655-5	AIR FEED VALVE ASSY	69
							68
	REF	-	-	A	24042-2	VALVE, SHUT OFF	67
④	REF	-	-	C	692655-6	AIR FEED VALVE ASSY	66
④	1	-	-	B	1-460277-5	AIR FEED ASSY (2 INCH)	65
2	2	-	-	A	3-21000-9	SCR, 5HC (10-32x2.00) AIR ASSY	64
-	1	-	-	A	980285-2	ELBOW, SWIVEL 1/8 NPT - 1/4 T	63
-	1	-	-	A	23238-1	QUICK DISCONNECT	62
-	12.00	IN	-	A	27319-4	TUBING, POLY-FLO ∅.25	61
④	-	1	-	B	1-460277-9	AIR FEED ASSY (2 INCH)	60
1	1	-	-	C	454220-1	CAP, RAM	59
1	1	-	-	D	453736-1	HOUSING	58
							57
							56
							55
							54
④	1	1	-	B	460680-1	FEED FINGER ASSY	53
							52
							51
							50
							49
-	1	-	-	A	22374-7	VALVE, QUICK EXHAUST	48
-	1	-	-	A	22304-1	NIPPLE, HEX 1/8 NPT	47
							46
1	1	-	-	A	690191-1	PLUG, NYLON	45
1	1	-	-	C	455674-1	RAM	44
1	1	-	-	A	690125-1	WASHER, LAMINATED	43
1	1	-	-	A	690124-5	WASHER, RAM	42
1	1	-	-	A	690686-1	BOLT, CRIMPER (5/16-24x1.00)	41
1	1	-	-	A	23241-6	BALL, STEEL	40
1	1	-	-	A	690170-1	SPRING, COMPRESSION	39
1	1	-	-	C	1-690142-0	DISC, INSULATION	38
1	1	-	-	D	354777-1	WIRE DISC, PLASTIC	37
1	1	-	-	A	22480-5	WASHER, SPRING	36
1	1	-	-	B	690212-1	POST, RAM	35
							34
							33
							32
							31
1	1	-	-	B	458031-2	GUIDE, STRIP	30
1	1	-	-	B	458030-2	GUIDE, STRIP	29
1	1	-	-	B	3-690451-2	SPACER, STRIPPER	28
1	1	-	-	A	240639-1	STRIPPER	27
1	1	-	-	D	455676-1	PLATE, BASE	26
2	2	-	-	A	22354-8	DRAG, STUD	25
1	1	-	-	B	455678-1	PLATE, STRIP GUIDE	24
							23
2	2	-	-	A	4-22281-1	SPRING, DRAG	22
							21
1	1	-	-	A	454177-1	DRAG, STOCK	20
1	1	-	-	B	1-458030-5	GUIDE, STRIP (REAR)	19
1	1	-	-	C	1-458031-5	GUIDE, STRIP (FRONT)	18
							17
							16
							15
2	2	-	-	C	2-240641-9	SPACER, SLUG BLADE	14
1	1	-	-	C	1-690481-0	SPACER, HOLD DOWN	13
1	1	-	-	A	23846-1	SPRING, HOLD DOWN	12
④	1	1	-	B	240644-1	PLATE, REAR SHEAR	11
							10
④	1	1	-	B	690482-4	PLATE, FRONT SHEAR	9
④	1	1	-	D	2-356038-8	ANVIL	8
④	1	1	-	B	1-690474-7	BLADE, SLUG	7
④	1	1	-	D	455892-4	HOLD DOWN, TERMINAL	6
							5
④	1	1	-	B	238009-2	SPACER, BLOCK CRIMPER	4
④	1	1	-	C	1-1213077-6	CRIMPER, INSULATION	3
④	1	1	-	B	1-455888-7	SPACER, CRIMPER	2
④	1	1	-	C	456428-3	CRIMPER, WIRE	1

QTY	REV	U/M	DWG SIZE	PART NO	DESCRIPTION	ITEM NO
-2	-1					

DIMENSIONS IN INCHES. DO NOT SCALE PRINT. TOLERANCES UNLESS OTHERWISE SPECIFIED:

DR 05NOV98 APP 05NOV98
P.Mathias T.ELBIN
CHK 05NOV98 REL -
C.ERISMAN

AMP Incorporated Harrisburg, PA 17105-3608

NAME: END FEED HDM APPLICATOR MACHINE REF: MINI APPL

SCALE: - DWG NO: 680749 SHEET: 1 OF 1 REV: B

THIS DRAWING IS A CONTROLLED DOCUMENT.

THIS DRAWING IS UNCLASSIFIED DATE 05-21-2013 BY 60322/UC/STP/STP

LOC A DIST 66