

THIS DOCUMENT IS THE PROPERTY OF KEYSTONE ELECTRONICS CORP. AND SHALL NOT BE REPRODUCED, DISTRIBUTED OR USED AS A BASIS FOR MANUFACTURE WITHOUT PRIOR WRITTEN PERMISSION FROM KEYSTONE ELECTRONICS CORP.

**ACTUAL SIZE**

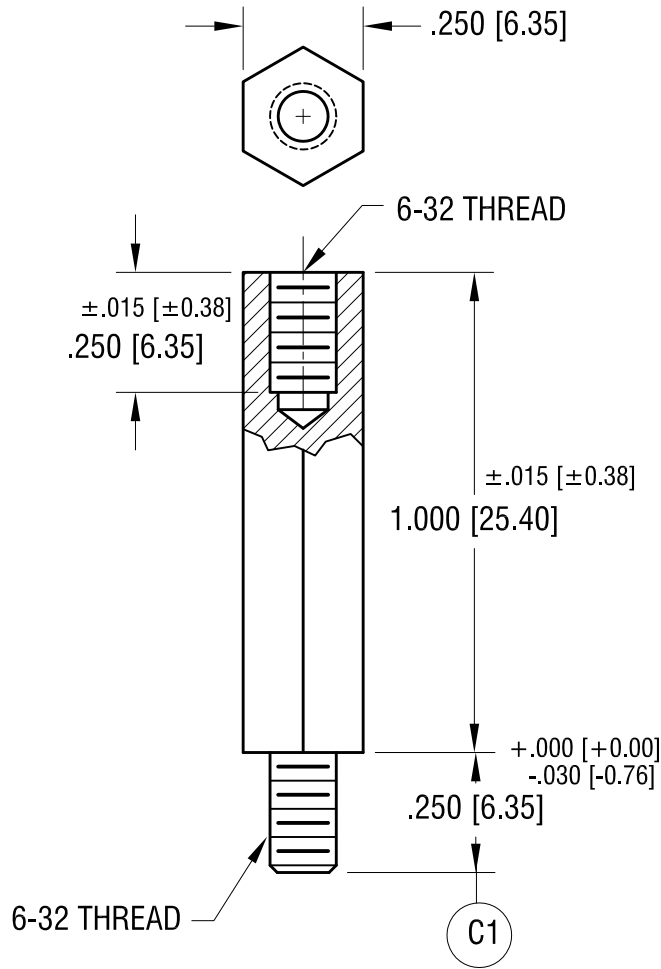

**NOTE:**

1. MAT'L- HIGH TEMPERATURE ,  
HIGH PERFORMANCE NYLON (COLOR- BLACK)
2. TEMPERATURE RANGE: -20°F [-29°C] to +365°F [+185°C]

4.17.23	(C1) WAS .250±.015 CHANGE AS PER ECN23-056	C
1.13.22	TEMP. WAS -20°F to +400°F CHANGE AS PER ECN 22-021	B
6.15.20	GENERAL TOLERANCE WAS ±.005 CHANGE AS PER ECN 20-054	A
DATE	DESCRIPTION	REV.

<b>KEYSTONE ELECTRONICS CORP.</b>			
www.keyelco.com • NEW HYDE PARK, NY 11040 • Tel (516) 328-7500			
PART NAME <b>HIGH TEMPERATURE NYLON STANDOFF</b>			
MATERIAL <b>AS NOTED</b>			
FINISH <b>NONE</b>		DRN BY <b>NT</b>	DATE <b>11.30.17</b>
		APP'D <b>RH</b>	SCALE <b>2.5X</b>
TOLERANCES	INCH [MM]	CODE	DWG NO.
DECIMAL	± .010 [± 0.25]	<b>C</b>	<b>4976</b>
ANGULAR	± 1°		
UNLESS OTHERWISE SPECIFIED			