



Loadmonitors - GAMMA series
 True power monitoring in 1- or 3-phase mains
 Analog output 4...20mA
 Suitable for VFI (10 to 100Hz)
 Zoom voltage 24V to 240V DC and 48V to 240V AC
 Width 22.5mm
 Industrial design



Read and understand these instructions before installing, operating or maintaining the equipment.



Danger!

Never carry out work on live parts! Danger of fatal injury! The product must not be used in case of obvious damage. To be installed by an authorized person.

Technical data

1. Functions

True power monitoring in 1- and 3-phase mains with analog output 4 ... 20mA and the following settings which are selected by means of rotary switch:

Zero	setting of zero point (0%, 25%, 50%, 75% of nominal value)
Zero Fine	fine setting of zero point (0% ... 25% of nominal value)
Span	span (100%, 75%, 50%, 25% of nominal value)
Range	measuring range reversible between 0.75kW, 1.5kW, 3kW, 6kW

2. Indicators

Green LED U ON: indication of supply voltage
 Yellow LED's ON/OFF: indication analog output 4...20mA

3. Mechanical design

Self-extinguishing plastic housing, IP rating IP40
 Mounted on DIN-Rail TS 35 according to EN 60715
 Mounting position: any
 Shockproof terminal connection according to VBG 4 (PZ1 required), IP rating IP20
 Tightening torque: max. 1Nm
 Terminal capacity:
 1 x 0.5 to 2.5mm² with/without multicore cable end
 1 x 4mm² without multicore cable end
 2 x 0.5 to 1.5mm² with/without multicore cable end
 2 x 2.5mm² flexible without multicore cable end

4. Input circuit

Supply voltage: 24V to 240V d.c.
 48V to 240V a.c.
 Terminals: A1-A2 (galvanically separated)
 Tolerance:
 48V to 240V a.c. -15% to +10%
 24V to 240V d.c. -20% to +25%
 Rated frequency:
 48 to 400Hz 48V to 240V a.c.
 Rated consumption: 2.5VA (1.3W)
 Duration of operation: 100%
 Reset time: 500ms
 Ripple and noise: -
 Drop-out voltage: >30% of supply voltage
 Overvoltage category: III (in accordance with IEC 60664-1)
 Rated surge voltage: 4kV

5. Output circuit

1 analog output 4...20mA
 Terminals: X1(+) - X2(-)
 Settling time: <450ms
 Burden: max. 500Ω
 Galvanic isolation: 3kV d.c.

6. Measuring circuit

Measuring range P_N : reversible between
 0.75kW, 1.5kW, 3kW, 6kW
 Wave form
 a.c. Sinus: 10 to 400Hz
 Sinus weighted PWM: 10 to 100Hz
 Measuring input voltage: terminals L1-L2-L3
 1-phase mains 0 to 480V a.c.
 3-phase mains 3~ 0 to 480/277V
 Overload capacity:
 1-phase mains 550V a.c.
 3-phase mains 3~ 550/318V
 Input resistance: 1.25MΩ
 Measuring input current: terminal i-k
 Measuring range 0.75kW, 1.5kW: 0 to 6A
 Measuring range 3kW, 6kW: 0 to 12A (for I>8A distance >5mm)
 Overload capacity: 12A permanent
 Input resistance: <10mΩ
 Overvoltage category: III (in accordance with IEC 60664-1)
 Rated surge voltage: 4kV

7. Accuracy

Base accuracy: ±2% (of maximum scale value)
 Frequency influence: ±0.025% / Hz
 Voltage influence: -
 Temperature influence: ≤0.05% / °C

8. Ambient conditions

Ambient temperature: -25 to +55°C
 (in accordance with IEC 60068-1)
 -25 to +40°C
 (in accordance with UL 508)
 Storage temperature: -25 to +70°C
 Transport temperature: -25 to +70°C
 Relative humidity: 15% to 85%
 (in accordance with IEC 60721-3-3
 class 3K3)
 Pollution degree: 3 (in accordance with IEC 60664-1)
 Vibration resistance: 10 to 55Hz 0.35mm
 (in accordance with IEC 60068-2-6)
 15g 11ms
 (in accordance with IEC 60068-2-27)
 Shock resistance:

Functions

Zero = 0% / Span = 25% ; Zero = 0% / Span = 100%

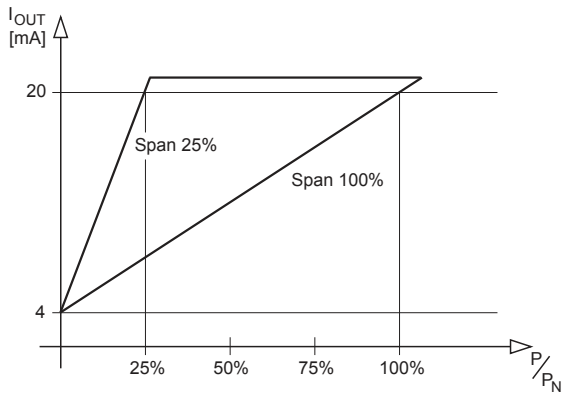

Zero = 25% / Span = 25% ; Zero = 25% / Span = 75%

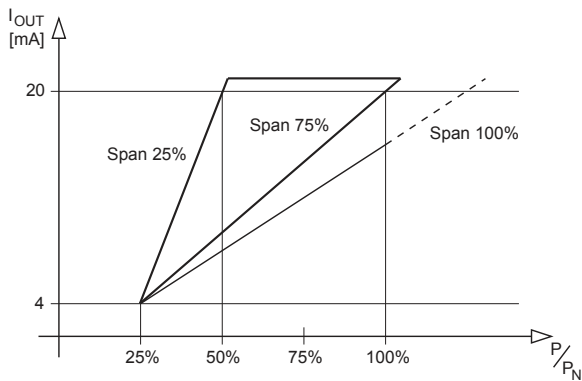

Zero = 37,5% / Span = 50% ; Zero = 37,5% / Span = 100%

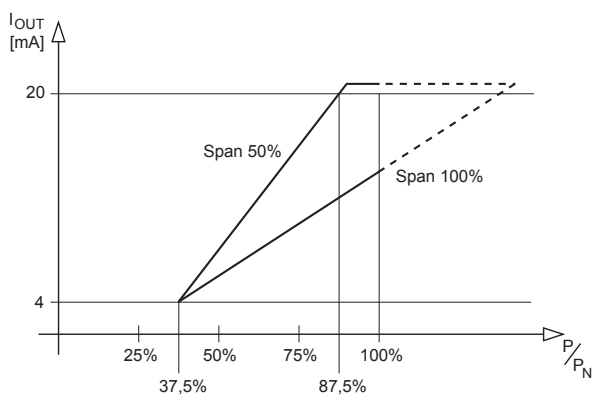

Connections

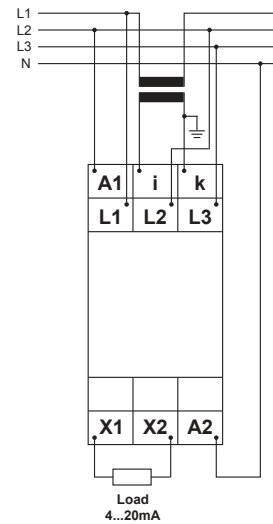
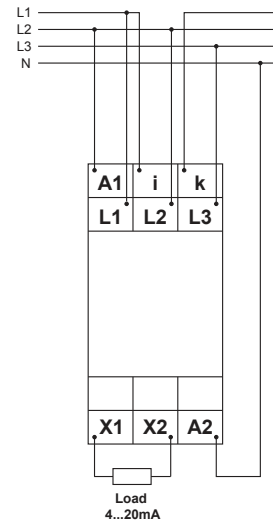

Dimensions

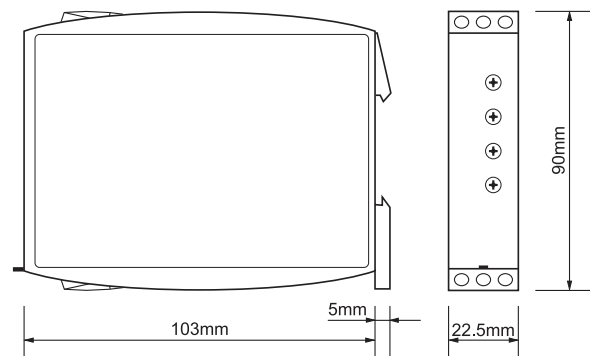

TELE Haase Steuergeräte Ges.m.b.H.
Vorarlberger Allee 38
A-1230 Wien

RELEASE 2012/08

Subject to alterations and errors

tele
Technik Braucht Kontrolle