

PART NUMBER
10145289-XYZLF

SEE TABLE

OCTIS WIDE BODY UNIVERSAL PLUG KIT SUITABLE FOR MPO TO QSFP

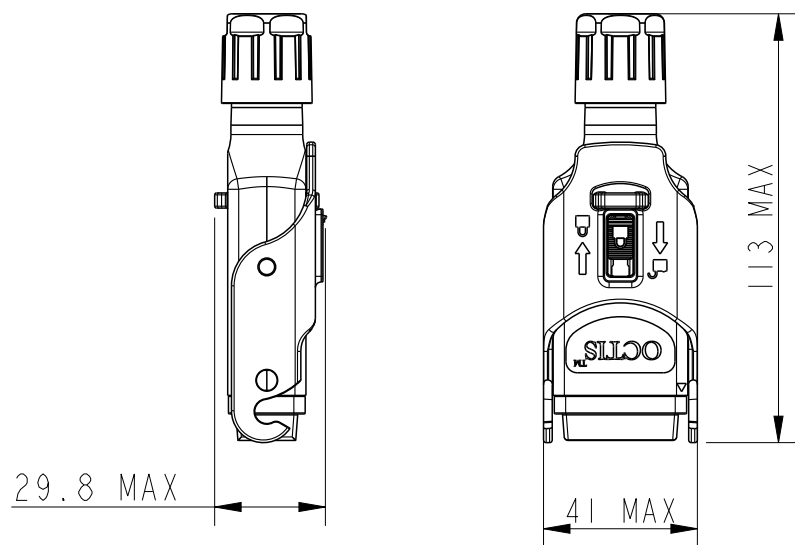
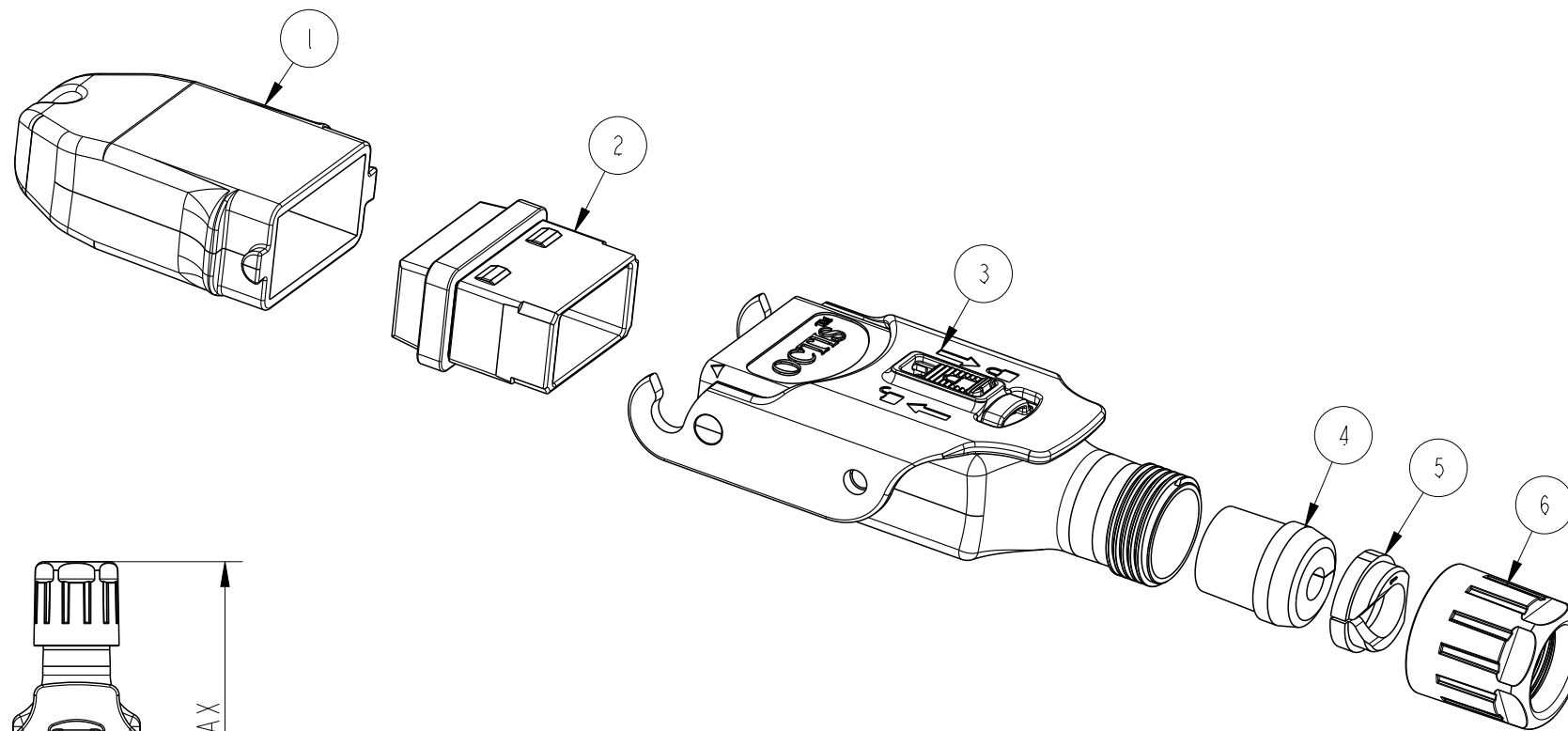

BOM OF PLUG KIT PART NO. 10145289-XYZLF				
SL.NO	COMPONENT	MATERIAL	QTY	REMARKS
1	PLUG CAP	PBT GF	1	-
2	HOLDER SUB KIT	SILICONE+PBT GF	1	-
3	HOUSING SUB KIT	PBT GF+IXEF	1	-
4	SPLIT RUBBER GLAND	SILICONE	1	-
5	TIGHTENING CONE	PA	1	-
6	NUT	PBT GF	1	COLOUR BLUE

AFCI PN	GLAND INNER DIA	CABLE SPEC	QTY
10145289-101LF	6MM	SEE PAGE 2	1
10145289-102LF	8MM		1
10145289-201LF	6MM, 8MM		2
10145289-202LF	10MM, 11.5MM		2

*OPTIONAL RUBBER GLAND INNER DIA OF 7MM AND 9MM AVAILABLE ON REQUEST

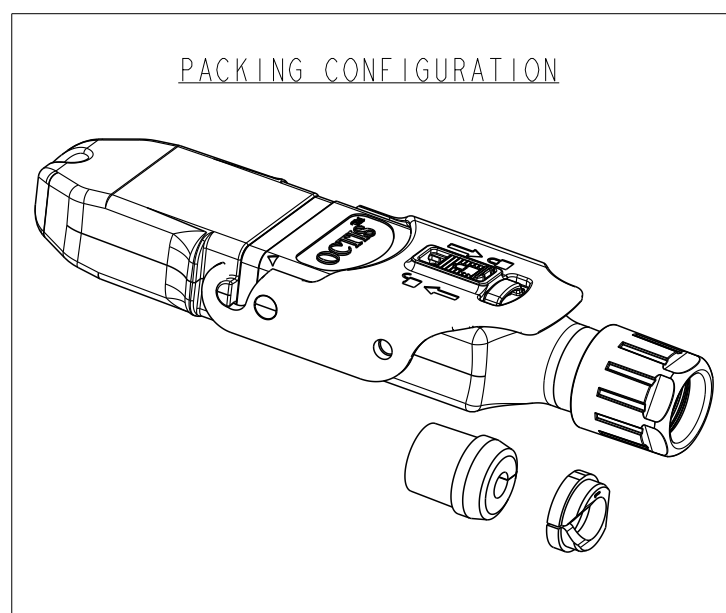

spec ref	dr	Varghese, Bone	2018/01/16	projection	mm	size	A3	scale	3:10
tolerance std	eng	Varghese, Bone	2019/08/13			ecn no	ELX-I-34402-1	rel level	Released
TOLERANCES UNLESS OTHERWISE SPECIFIED									
surface	linear	0.X	±0.3		WIDE BODY UNIVERSAL PLUG KIT FOR MPO TO QSFP OCTIS FIELD TERMINABLE, PITCH 41 MM	dwg no	10145289	rev	E
		0.XX	±.13						
		0.XXX	±.050						
ISO 1302	angular	0°	±2°	cat. no.	Product - Customer Drw	sheet 1 of 2			

Amphenol
FCI

© 2016 AFCI

GENERAL CHARACTERISTICS

Mechanical		
Mating endurance (cycles)	IEC 61300-2-2	100
Axial Tensile load (N min)	IEC 61300-2-4	150
Vibration	IEC 61300-2-1	-
Recom. coupling torque (N.cm)	-	200 min / 250 max
Weight (g)	-	64.87
Environmental		
Protection class (mated condition)	IEC 60529	IP67 (*)
Operating temperature (°C)	IEC 61300-2-22	-40 / +85
Storage temperature (°C)	IEC 61300-2-22	-40 / +85
Humidity (damp heat) (%RH)	IEC 61300-2-19	5 / 95
Salt Mist	IEC 61300-2-26 (ISO21207 method B)	720h (To be tested) (*)
RoHS	-	Compliant
Flammability	UL 94	V0
UVB Resist	ASTM G154	Compliant
Others:		
Cable	-	Diameter Cable TBD ± 0.2 mm For other cable diameter, contact us.
Packaging	-	Unitary in plastic bag. With assembly note

(*) Mated condition

CABLE OUTER DIAMETER (MM)	RECOMMENDED GLAND SIZE
FROM 4.8 MIN TO 5.8 MAX	"6"
FROM 5.8 MIN TO 6.8 MAX	"7"
FROM 6.8 MIN TO 7.8MAX	"8"
FROM 7.8 MIN TO 8.8MAX	"9"
FROM 8.8 MIN TO 9.8MAX	"10"
FROM 10.3 MIN TO 11.3MAX	"11.5"

spec ref	dr	Varghese, Bone	2018/01/16	projection	mm	size	A3	scale	3:10
tolerance std	eng	Varghese, Bone	2019/08/13			ecn no ELX-I-34402-1			
TOLERANCES UNLESS OTHERWISE SPECIFIED						product family	OCTIS	rel level Released	
surface	linear	0.X	±0.3		WIDE BODY UNIVERSAL PLUG KIT FOR MPO TO QSFP OCTIS FIELD TERMINABLE, PITCH 41 MM	dwg no 10145289	rev E		
		0.XX	±.13						
		0.XXX	±.050						
ISO 1302	angular	0°	±2°	cat. no.	Product - Customer Drw	sheet 2 of 2			