

THIS DRAWING IS SUPPLIED FOR INFORMATION ONLY. DESIGN FEATURES, SPECIFICATIONS AND PERFORMANCE DATA SHOWN HEREON ARE THE PROPERTY OF THE AMPHENOL CORPORATION. NO RIGHTS OF REPRODUCTION ARE IMPLIED. ALL DIMENSIONS ARE SUBJECT TO NORMAL MANUFACTURING VARIATIONS.

CUSTOMER DRAWING

REVISIONS				
REV	DESCRIPTION	DATE	BY	APPR
A	INITIAL RELEASE	01/26/14	DH	EC
B	ADD "X"、"K" DIMENSION	03/19/14	DH	EC
C	ADD SIZE 14.0mm	06/12/14	DH	EC
D	CHANGE DIMENSION "H" FOR SIZE 10.0	09/23/14	DH	EC
E	Add a view of 10.0 and 14.0	01/11/18	KW	JG

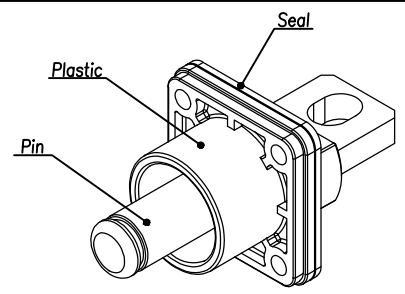

RADLOK 3.6mm,5.7mm,8.0mm,12.00mm

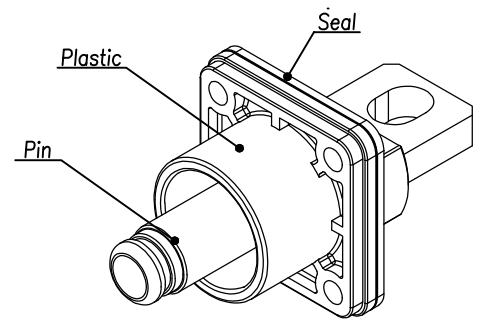

RADLOK 10.0mm and 14.0mm

Ordering Example:

RL 9 080 - 20 X - F1

RadLok _____
 RadLok Pin _____
 RadLok Size: \varnothing 8.0mm _____
 Pin To Lug _____
 Plating: 1 - Silver _____
 2 - Tin _____
 3 - Nickel _____
 Feed Thru _____

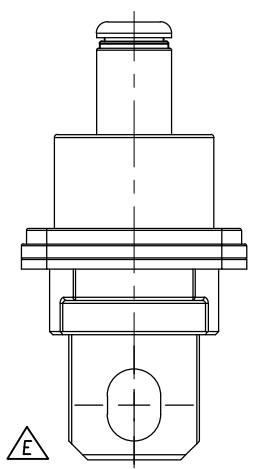

Only for 10.0mm and 14.0mm

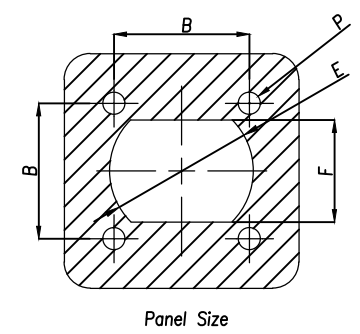
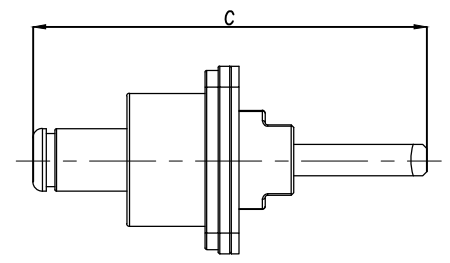
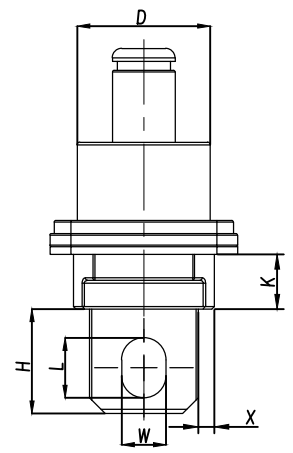
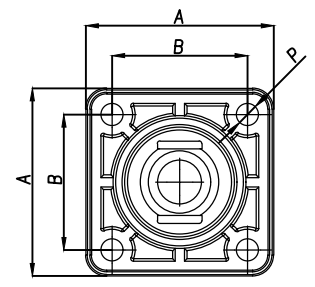

Specification

Size (mm)	A (mm)	B (mm)	C (mm)	D (mm)	E (mm)	F (mm)	H (mm)	L (mm)	W (mm)	X (mm)	K (mm)	P	Current (A)	Ordering Number (XXX-For Plating)	Plating
3.6	21.0	14.0	46.7	11.9	12.5	10.3	13.5	5	4.2	1.9	11.3	M3	70	RL9036-20X-F1	1 Silver 2 Tin 3 Nickel
5.7	25.0	17.0	53.6	15.2	14.5	12.4	16.0	7	6.3	2.0	12.0	M4	120	RL9057-20X-F1	
8.0	30.0	21.0	62.5	19.6	22.1	15.6	22.5	10.0	8.5	2.7	8.0		200	RL9080-20X-F1	
10.0	33.0	24.0	70.0	23.0	25.6	17.6	22.5	12.5	10.5	3.55	9.5		300	RL9100-20X-F1	
12.0	36.0	26.0	77.5	25.5	27.6	19.6	27.5	14.0	13.0	3.0	10.5		400	RL9120-20X-F1	
14.0	37.0	27.0	90.0	28.0	26.2	21.7	29.0	15.5	14.5	2.3	13.0		500	RL9140-20X-F1	



	Amphenol Technical Products International GZ				PART NAME: RADLOK® Feed Thru Pin To Lug	
	第三角投影 THIRD ANGLE PROJECTION	页面 SHEET 1 OF 2	幅面 SIZE A3	版次 REV. E	比例 SCALE	DWG NO: See Table
签名 SIGNATURE 制图 DRAWN: KW 审核 CHECKED: SAM 批准 APPROVAL: JG	日期 DATE 01/11/2018	UNLESS OTHERWISE SPECIFIED 1) All dimensions are in metric(mm). 2) Tolerances are as follows: 0 PL DEC ±1.00 1 PL DEC ±0.50 2 PL DEC ±0.20			CUST PART #: N/A	
				Angles ±1°	CUST REV. E	

THIS DRAWING IS SUPPLIED FOR INFORMATION ONLY. DESIGN FEATURES, SPECIFICATIONS AND PERFORMANCE DATA SHOWN HEREON ARE THE PROPERTY OF THE AMPHENOL CORPORATION. NO RIGHTS OF REPRODUCTION ARE IMPLIED. ALL DIMENSIONS ARE SUBJECT TO NORMAL MANUFACTURING VARIATIONS.

CUSTOMER DRAWING

REVISIONS				
REV	DESCRIPTION	DATE	BY	APPR
A	INITIAL RELEASE	01/26/14	DH	EC
B	ADD "X"、"K" DIMENSION	03/19/14	DH	EC
C	ADD SIZE 14.0mm	06/12/14	DH	EC
D	CHANGE DIMENSION "H" FOR SIZE 10.0	09/23/14	DH	EC
E	Add a view of 10.0 and 14.0	01/11/18	KW	JG

Table				
Plating Type	Description	FG P/N(BK)	FG P/N(OR)	FG P/N(RE)
Silver 镀银	RL9036-201-F1 M4	AC-HA000385	AC-HA001623	AC-HA001713
	RL9048-201-F1 M5	AC-HA000386	AC-HA001624	AC-HA001714
	RL9057-201-F1 M6	AC-HA000387	AC-HA001625	AC-HA001715
	RL9080-201-F1 M8	AC-HA000388	AC-HA001626	AC-HA001716
	RL9091-201-F1 M9	AC-HA000389	AC-HA001627	AC-HA001717
	RL9100-201-F1 M10	AC-HA000390	AC-HA001628	AC-HA001718
	RL9120-201-F1 M12	AC-HA000391	AC-HA001629	AC-HA001719
Tin 镀锡	RL9140-201-F1 M14	AC-HA000392	AC-HA001630	AC-HA001720
	RL9036-202-F1 M4	AC-HA001024	AC-HA001653	AC-HA001743
	RL9048-202-F1 M5	AC-HA001025	AC-HA001654	AC-HA001744
	RL9057-202-F1 M6	AC-HA001026	AC-HA001655	AC-HA001745
	RL9080-202-F1 M8	AC-HA001027	AC-HA001656	AC-HA001746
	RL9091-202-F1 M9	AC-HA001028	AC-HA001657	AC-HA001747
	RL9100-202-F1 M10	AC-HA001029	AC-HA001658	AC-HA001748
Nickel 镀镍	RL9120-202-F1 M12	AC-HA001030	AC-HA001659	AC-HA001749
	RL9140-202-F1 M14	AC-HA001031	AC-HA001660	AC-HA001750
	RL9036-203-F1 M4	AC-HA000334	AC-HA001683	AC-HA001773
	RL9048-203-F1 M5	AC-HA000335	AC-HA001684	AC-HA001774
	RL9057-203-F1 M6	AC-HA000336	AC-HA001685	AC-HA001775
	RL9080-203-F1 M8	AC-HA000337	AC-HA001686	AC-HA001776
	RL9091-203-F1 M9	AC-HA000338	AC-HA001687	AC-HA001777
RL9100-203-F1 M10	AC-HA000339	AC-HA001688	AC-HA001778	
RL9120-203-F1 M12	AC-HA000340	AC-HA001689	AC-HA001779	
RL9140-203-F1 M14	AC-HA000341	AC-HA001690	AC-HA001780	

	Amphenol Technical Products International GZ					
	第三角投影 THIRD ANGLE PROJECTION 	页面 SHEET 2 OF 2	幅面 SIZE A3	版次 REV. E	比例 SCALE	PART NAME: RADLOK® Feed Thru Pin To Lug
签名 SIGNATURE 制图 DRAWN 审核 CHECKED 批准 APPROVAL	日期 DATE KW SAM JG	01/11/2018 01/11/2018 01/11/2018	UNLESS OTHERWISE SPECIFIED 1) All dimensions are in metric(mm). 2) Tolerances are as follows: 0 PL DEC ±1.00 1 PL DEC ±0.50 2 PL DEC ±0.20			DWG NO: See Table
				Angles ±1°	CUST PART #: N/A	

1 2 3 4 5 6 7 8

A B C D E F

1 2 3 4 5 6 7 8