

PRODUCT NUMBER (SEE NOTE 2)	CONTACT PLATING		ROHS COMPATIBILITY
	SEPARABLE INTERFACE	PRESS-FIT TAIL	
10028917-001	0.76um MIN GXT OVER NICKEL	0.5um MIN TIN-LEAD OVER NICKEL	N/A
10028917-001LF		0.5um MIN MATTE TIN OVER NICKEL	SEE NOTE 8

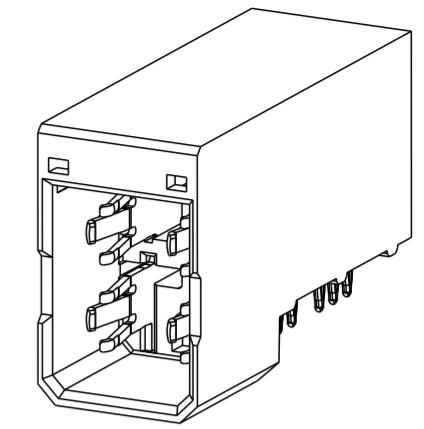

SCALE 2:1

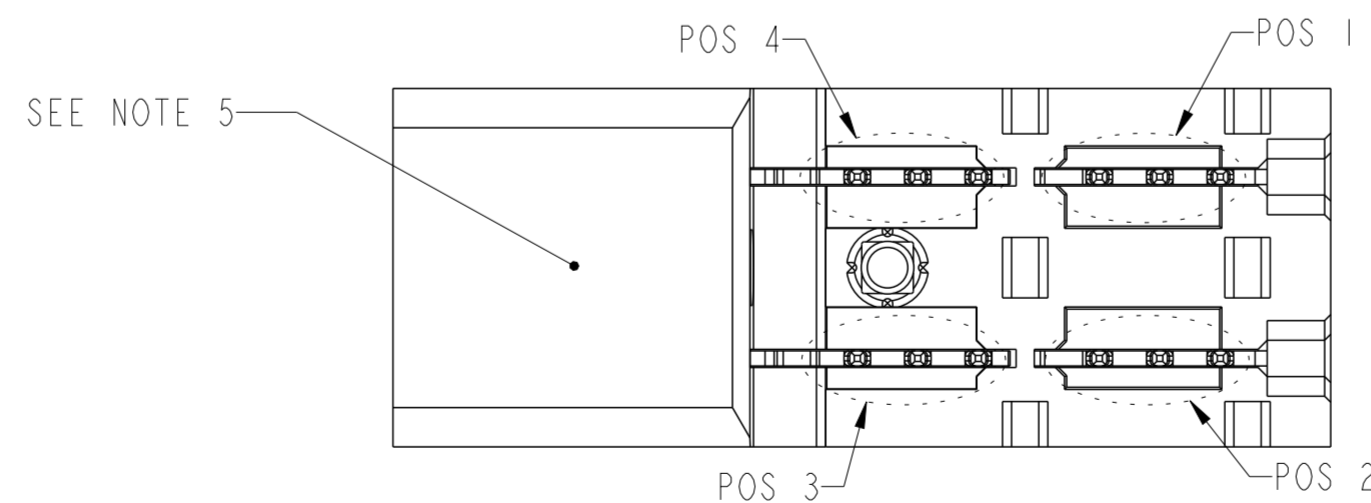
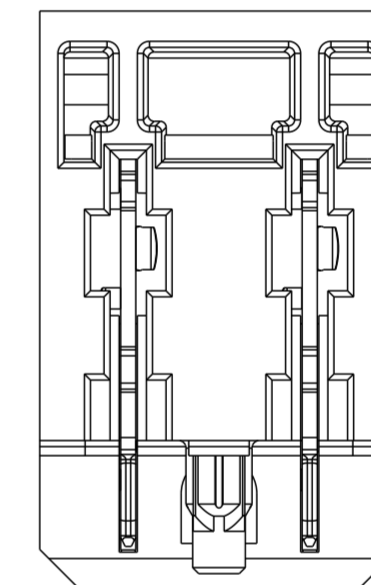
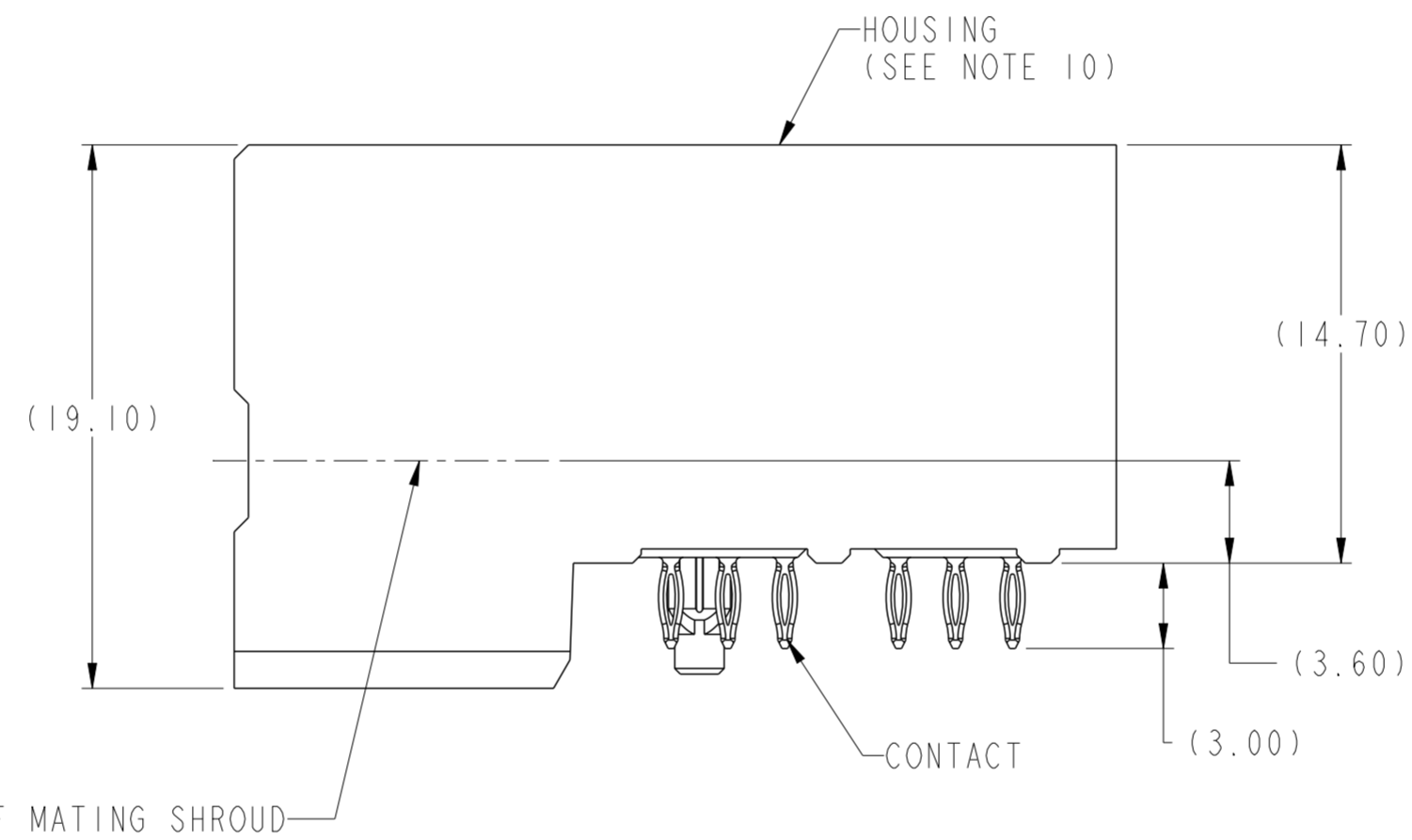
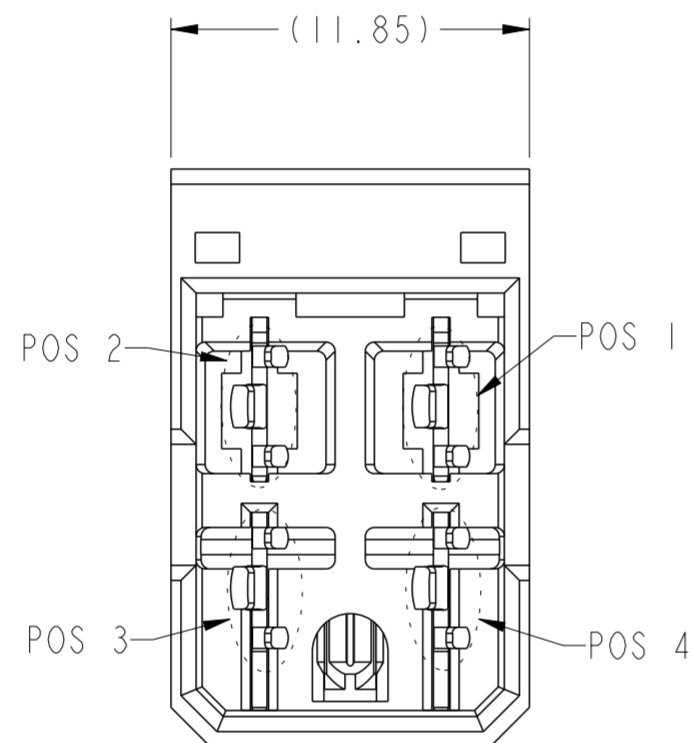
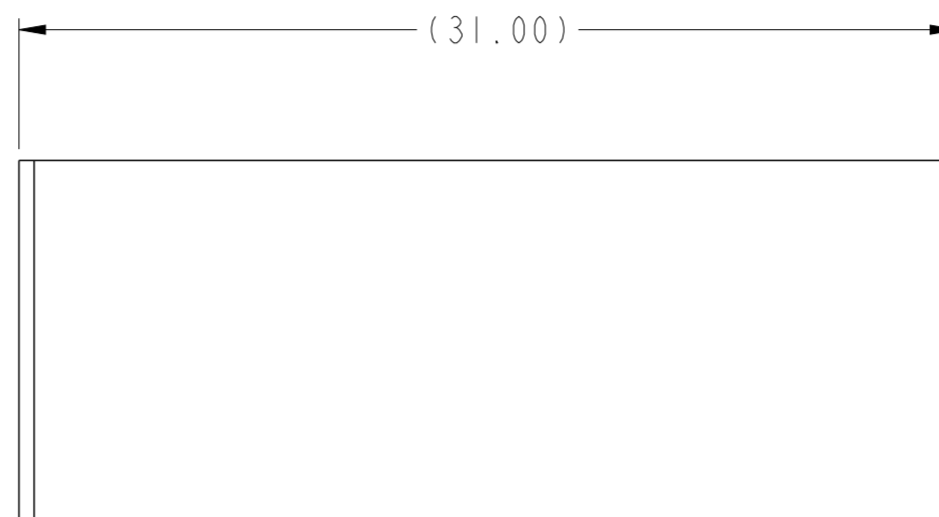

spec ref	GS-12-220	dr	Chen-Hong Yan	2005/08/04	projection	MM	size	A2	scale	4:1
tolerance std	ASME Y14.5	eng	Terry Luo	2019/04/23			ecn no	ELX-DG-33324-1		
TOLERANCES UNLESS OTHERWISE SPECIFIED		chr	-					rel level	Released	
surface	linear	0.X	±.3		product family	2mm High Power		title R/A HEADER ASSY 2X2 AIRMAX POWER cat. no.	dwg no 10028917	rev H
		0.XX	±.1							
		0.XXX	±.050							
ASME Y14.5	angular	0°	±2°							
					Product - Customer Drw		sheet 1 of 2			

PDS: Rev :H

STATUS:Released

Printed: Apr 25, 2019

Amphenol
FCi

© 2016 AFci

