

Evaluation Board for a Quad Channel, 16-Bit, Serial Input, 4 mA to 20 mA, Voltage Output DAC with Dynamic Power Control and HART Connectivity

FEATURES

Full-featured evaluation board for the [AD5755](#), [AD5755-1](#), and [AD5757](#)

Link options

PC control in conjunction with Analog Devices, Inc., system demonstration platform (SDP)

PC software for control

GENERAL DESCRIPTION

This user guide describes a full-featured evaluation board that is designed to allow the user to easily evaluate all features of the [AD5755](#), [AD5755-1](#), or [AD5757](#), quad channel, 16-bit current source and voltage output DAC with dynamic power control and HART connectivity. The board can be controlled by two means: via the on-board connector (J11) or via the SDP connector (J9). The SDP board allows the evaluation board to be controlled through the USB port of a Windows® XP (SP2 or later), Windows Vista (32-bit or 64-bit), or Windows 7 (32-bit or 64-bit) based PC using the AD575X evaluation software.

DEVICE DESCRIPTION

The [AD5755](#) is a quad, voltage and current output DAC that operates with a power supply range from -26.4 V to $+33\text{ V}$. On-chip dynamic power control minimizes package power dissipation in current mode. This is achieved by regulating the voltage on the output driver from 7.4 V to 29.5 V .

The part uses a versatile 3-wire serial interface that operates at clock rates up to 30 MHz and is compatible with standard SPI, QSPI™, MICROWIRE™, DSP, and microcontroller interface standards. The interface also features optional CRC-8 packet error checking, as well as a watchdog timer that monitors activity on the interface.

The [AD5757](#) is a current output-only version of the [AD5755](#) and is HART compatible. The [AD5755-1](#) is identical to the [AD5755](#) except the $-V_{\text{SENSE}_x}$ functionality has been removed and, instead, the device is HART compatible. For both the [AD5757](#) and [AD5755-1](#), each channel has a corresponding CHART pin so that HART signals can be coupled onto the current output.

EVALUATION BOARD PHOTOGRAPH

Figure 1.

EVALUATION BOARD HARDWARE

POWER SUPPLIES

The following power supplies are required.

Table 1. Power Supply Connections

Connector	Nominal	Comment
AV _{DD}	15 V	Positive analog supply voltage. 10.8 V to 33 V range. (Green LED D2 lights up when power is supplied to AV _{DD} .)
AV _{SS}	-15 V/ +0 V	Negative analog supply voltage. -10.8 V to -26.4 V range, or 0 V for the AD5757 or AD5755-1 in unipolar supply mode.
AV _{CC}	5 V	DC-to-dc supply voltage. 4.5 V to 5.5 V range. The AV _{CC} input supplies all four on-board dc-to-dc blocks and may draw as much as 0.8 A peak current per channel, depending on the configuration (see the device data sheet for more information).
DV _{DD}	3.3 V	Supplied from the SDP connector. 2.7 V to 5.5 V range.
REFIN	5 V	See Table 4 for selecting the reference source: the DAC internal reference, the on-board ADR02 reference, or externally provided via the REFIN input.

Both analog AGND and PGND inputs are provided on the board. The PGND input is for the ground of the dc-to-dc converter circuitry, and a ground connection for the AV_{CC} supply should be made at this point. The AGND and PGND planes are connected at one location on the evaluation board. The AGND and DGND planes are connected at one location close to the [AD5755](#), [AD5755-1](#), or [AD5757](#) device. Each supply is decoupled to the relevant ground plane with 10 μF and 0.1 μF capacitors. Each device supply pin is also decoupled with a 10 μF and 0.1 μF capacitor pair to the relevant ground plane.

LINK OPTIONS

The link options on the evaluation board should be set for the required operating setup before using the board. The functions of the link options are described in Table 4.

Default Link Option Setup

The default link options are listed in Table 2.

Table 2. Default Link Options

Link No.	AD5755 Link Setup	AD5755-1 Link Setup	AD5757 Link Setup
LK0	Removed	Removed	Removed
LK1	Removed	Removed	Removed
LK2	Inserted	Inserted	Inserted
LK3	Inserted	Inserted	Inserted
LK4	Inserted	Inserted	Removed
LK5	Inserted	Removed	Removed
LK6	Inserted	Inserted	Removed
LK7	Inserted	Removed	Removed
LK8	Inserted	Inserted	Removed
LK9	Inserted	Removed	Removed
LK10	Inserted	Inserted	Removed
LK11	Inserted	Removed	Removed
LK12	Removed	Removed	Removed
LK13	Removed	Removed	Removed
LK14	Removed	Removed	Removed
LK15	Removed	Removed	Removed

Connector J11 Pin Descriptions

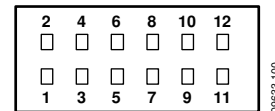

Figure 2. Connector J11 Pin Configuration

Table 3. Connector J11 Pin Descriptions¹

Pin No.	Description
1	DV _{DD}
2	DGND
3	SYNC
4	SCLK
5	SDIN
6	SDO (output)
7	LDAC
8	CLEAR
9	POC (AD5755 and AD5755-1)
10	RESET
11	FAULT (output)
12	ALERT (output)

¹ The SDP board must be disconnected when using the J11 connector.

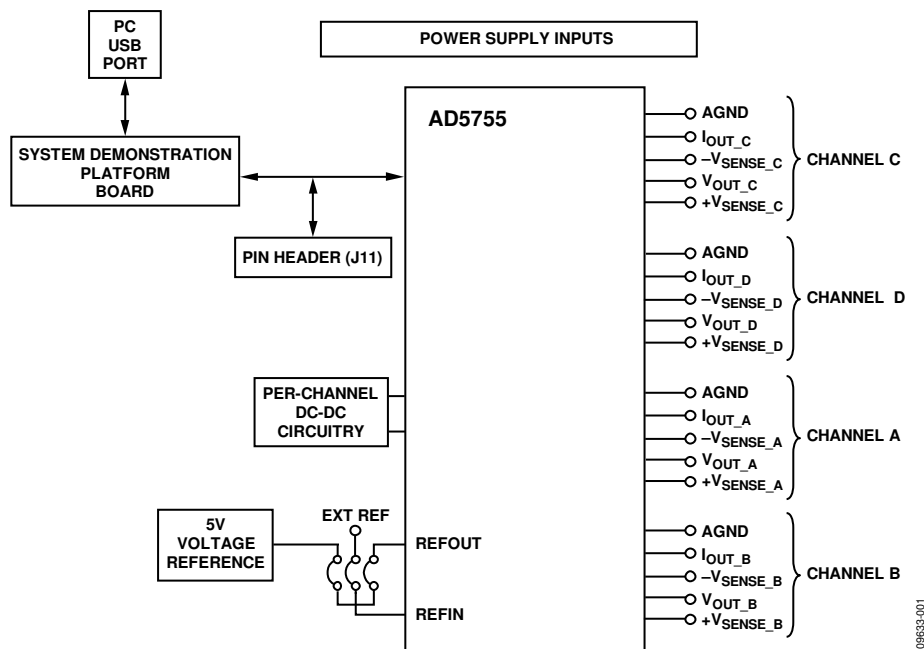

Figure 3. Evaluation Board Connection Diagram

Table 4. Link Options

Link No.	Device	Description
LK0, LK1, LK2	All models	These links select the voltage reference source (only one of these should be inserted at any one time). LK0 selects the internal voltage reference of the DAC as the voltage reference source. LK1 selects an external voltage reference source that can be applied at Connector J7. LK2 selects the on-board ADR02 as the voltage reference source. The ADR02 is supplied by the AV _{DD} supply and operates under the same input voltage range as the AV _{DD} input of the DAC, that is 9 V to 33 V.
LK3	All models	Powers the on-board ADR02 5 V reference by connecting the AV _{DD} supply to the ADR02 supply pin.
LK4, LK6 LK10, LK8	AD5755, AD5755-1	These links connect the +V _{SENSE} input to V _{OUT} for Channel A, Channel B, Channel C, and Channel D, respectively. When this link is inserted, the +V _{SENSE} input is connected directly to the V _{OUTx} pin. When this link is removed, the +V _{SENSE} input is left floating and should be connected to the high-side of the load resistance external to the evaluation board.
LK5, LK7 LK9, LK11	AD5755	These links connect the -V _{SENSE} input to V _{OUT} for Channel A, Channel B, Channel C, and Channel D, respectively. When this link is inserted, the -V _{SENSE} input is connected directly to the V _{OUT} pin. When this link is removed, the -V _{SENSE} input is left floating and should be connected to the high-side of the load resistance external to the evaluation board.
LK12, LK13, LK14, LK15	All models	These links allow connection of an external V _{BOOST} supply. (Remove Resistors R43, R44, R17, and R20 to use this feature.) When inserted, these connect the V _{BOOST} pin of Channel A, Channel B, Channel C, and Channel D, respectively, to the AV _{DD} supply. When removed, the V _{BOOST} supplies are controlled by the dc-to-dc converter circuitry.

EVALUATION BOARD SOFTWARE

SOFTWARE INSTALLATION

The evaluation kit includes self-installing software on a CD. The software is compatible with Windows XP (SP2), Windows Vista (32-bit or 64-bit), and Windows 7 (32-bit or 64-bit). If the setup file does not run automatically, you can run **setup.exe** from the CD.

Install the evaluation software before connecting the evaluation board and SDP board to the USB port of the PC to ensure that the evaluation system is correctly recognized when connected to the PC.

1. After installation from the CD is complete, power up the evaluation board as described in the Power Supplies section.
2. Next, connect the SDP board to the evaluation board and then to the USB port of your PC using the supplied cable.
3. When the evaluation system is detected, proceed through any dialog boxes that appear. This finishes the installation.

SOFTWARE OPERATION

To launch the software, complete the following steps:

1. From the **Start** menu, select **Analog Devices –AD575X Evaluation Software**, and then select **AD575X Evaluation Software**. The main window of the software opens (see Figure 6).

2. If the evaluation system is not connected to the USB port when the software is launched, a connectivity error is displayed (see Figure 5). Simply connect the evaluation board to the USB port of the PC, wait a number of seconds, and click **Rescan**. Follow the instructions. If you click **Cancel**, the software enters **Demonstration Mode**.

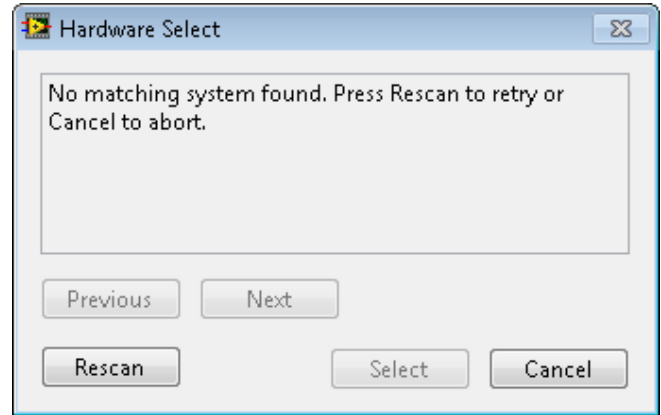

Figure 5. Connectivity Error Alert

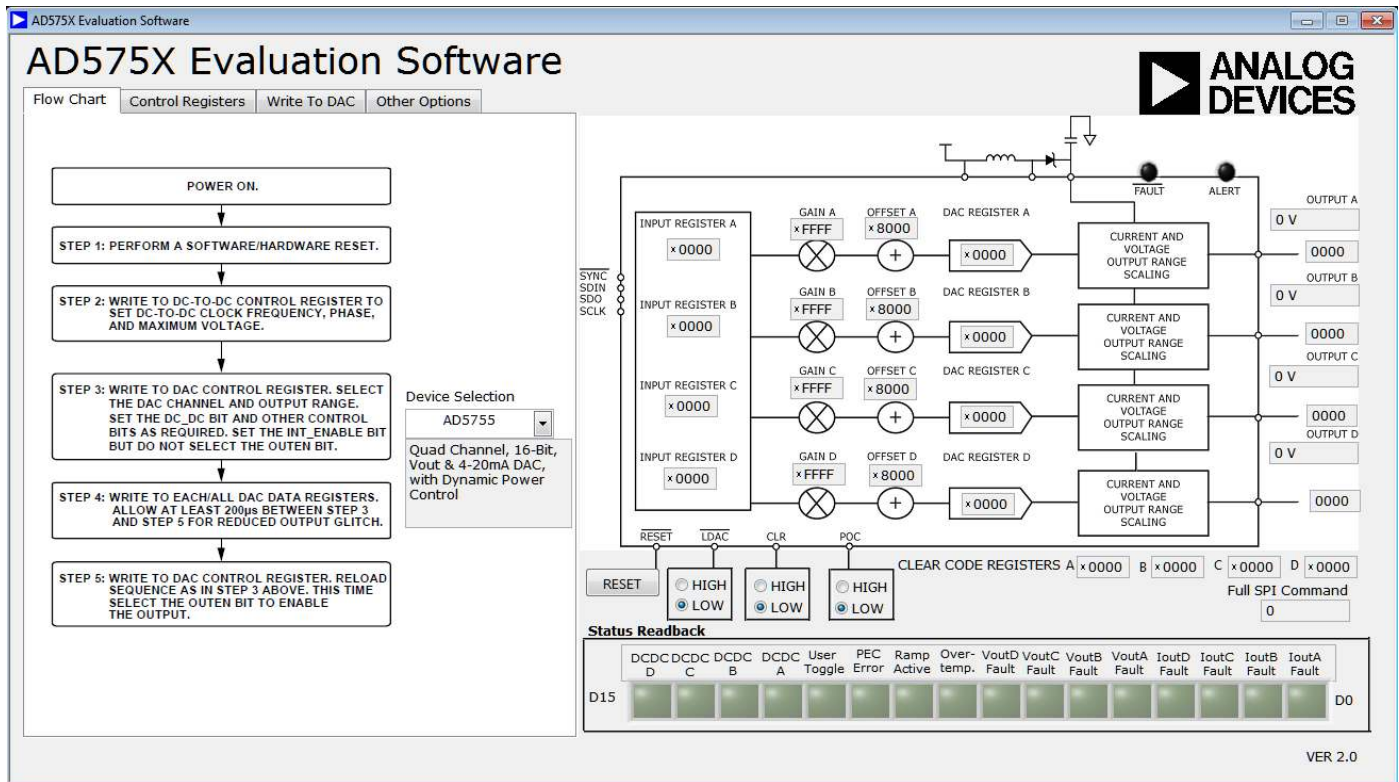

Figure 6. Main Window

DEMONSTRATION MODE

Demonstration mode is accessible when the evaluation board is not connected to the PC. It allows the user to operate the software without the evaluation board. The user will have access to the majority of the software's features and the GUI will simulate the evaluation board. In demonstration mode, all communication to the SDP is disabled. Exit and restart the software to connect to the evaluation board.

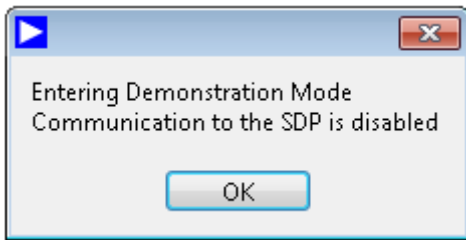

Figure 7. Evaluation Mode

SELECTING THE DEVICE

In the flow chart tab, select the main device on the board, either [AD5755](#), [AD5755-1](#), or [AD5757](#), from the drop-down list (see Figure 8) to adjust the available controls accordingly.

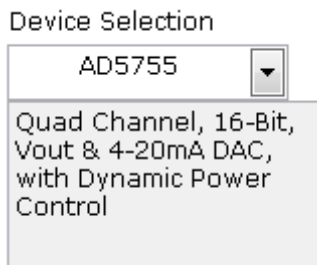

Figure 8. Device Selection

ENABLING THE OUTPUT CORRECTLY

To correctly write to and set up the part from a power-on condition, use the following sequence.

1. Perform a hardware or software reset after initial power-on.
2. The dc-to-dc converter supply block must be configured. Set the dc-to-dc switching frequency, maximum output voltage allowed, and the phase that the four dc-to-dc channels clock at.
3. Configure the DAC control register on a per channel basis. The output range is selected, and the dc-to-dc converter block is enabled (DC_DC bit). Other control bits can be configured at this point. Set the INT_ENABLE bit; however, the output enable bit (OUTEN) should not be set.
4. Write the required code to the DAC data register. This implements a full DAC calibration internally. Allow at least 200 μs before Step 5 for reduced output glitch.
5. Write to the DAC control register again to enable the output (set the OUTEN bit).

A flowchart of enabling the output correctly is shown in Figure 9.

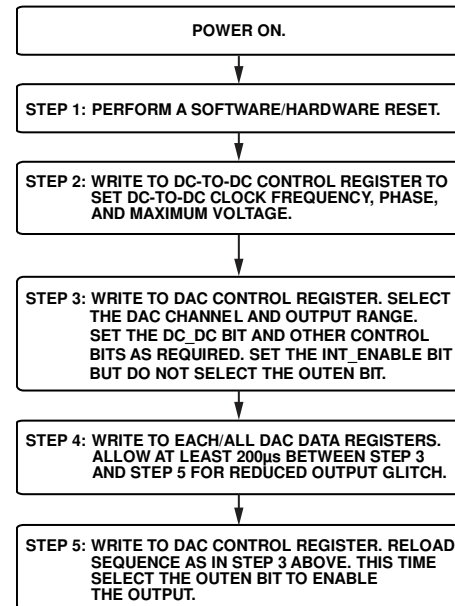

Figure 9. Programming Sequence for Enabling the Output Correctly

CHANGING AND REPROGRAMMING THE RANGE

When changing between ranges, the same sequence as described in the Enabling the Output Correctly section should be used. It is recommended to set the range to its zero point (can be midscale or zero scale) prior to disabling the output. Because the dc-to-dc converter switching frequency, maximum voltage, and phase have already been selected, there is no need to reprogram these.

A flowchart of changing and reprogramming the range is shown in Figure 10.

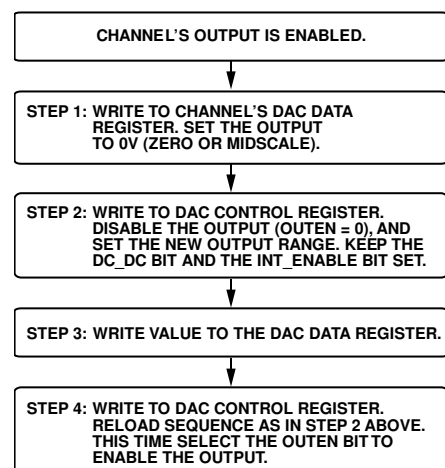

Figure 10. Steps for Changing the Output Range

CLEAR COMMAND

To clear an output, each relevant channel must have its clear code set in the relevant data register (default of 0x0000) and be enabled for clear operation via the DAC control registers. After these are set, assert the CLEAR pin to clear the selected channels.

CONTROL OF DIGITAL PINS

The RESET, LDAC, POC, and CLR pins can all be controlled by selecting HIGH/LOW in the relevant boxes shown in Figure 11. The FAULT and ALERT lights display the status of their respective pins. The FAULT and ALERT pins of the device are polled by the evaluation software every ~100 ms. The FAULT pin is also connected to the reference LED, D1, on the evaluation board, and ALERT is connected to the orange LED, D14.

WRITING TO DATA REGISTERS

This function allows you to write to all the data registers. Select the register to write to from the pull-down menu, enter the 16-bit data-word to be written (in hexadecimal) and click WRITE to load data to the register (see Figure 12). Note that the effect of the gain and offset register values on the output is only seen once the data register is written to.

READING FROM REGISTERS

This function allows you to read from all the data registers, control registers, and the status register. Select the register to read from the pull-down menu and click READ (see Figure 12). The 16 bits of LSB data appear in the number box in hexadecimal format. This function is unavailable in demonstration mode.

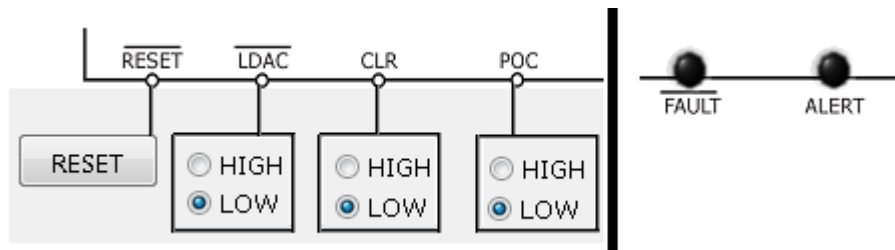

Figure 11. Digital Pin Controls and Indicators in the Evaluation Software

Select Channel To Write

- DAC A
- DAC B
- DAC C
- DAC D
- All DAC's

Select Register

Write to Data Register

Write To Register 0000 WRITE

Select Channel To Read

- DAC A
- DAC B
- DAC C
- DAC D

Select Register Read

Read from Data Register

READ 0000

Figure 12. Write to/Read From Data Register in the Evaluation Software

WRITING TO THE DAC CONTROL REGISTERS

This function allows you to write to and configure the DAC control register for a selected channel. Select the required DAC channel to be configured from the tab menu. After configuring the settings you require, click **WRITE TO CH A CTRL REG** to write to the device. The menu selection is shown in Figure 13.

Table 9. DAC Control Register Functions

Option	Description
INT_ENABLE	Powers up internal amplifiers. This should be done when enabling the output.
EN Clear	Selects if the channel clears when the CLEAR pin is activated.
EN Output (OUTEN)	Enables/disables the selected output channel.
Rset	Selects whether internal or external sense resistor is used when using a current range.
EN DC-DC	Powers up/down the dc-to-dc converter on a selected channel. To correctly power down the dc-to-dc converter, EN Output (OUTEN) and INT_ENABLE must also be disabled.
Over-Range	Enables/disables 20% overrange. This is available on V_{OUT} ranges only.
Output Range	Selects the output range for the specified channel.

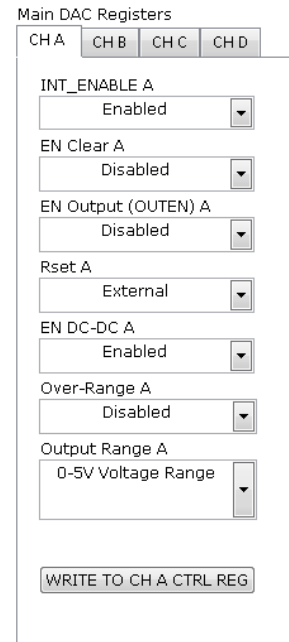

Figure 13. Write to the DAC Control Registers in the Evaluation Software

WRITING TO THE DC-TO-DC CONTROL REGISTER

The dc-to-dc control register function is located in the **Control Registers** tab (Figure 14). This function allows you to write to and configure the dc-to-dc control register. Select the required clamp voltage, switching frequency, and phase from the pull-down menu and click the **WRITE TO DC-DC CONTROL REGISTER** button to write the selected data to the device. On the evaluation board, the dc-to-dc converter perform best at a 410 kHz switching frequency (see the DC-to-DC Boost section). See the device data sheet for information on the DC-DC Comp bit. If selecting an external compensation resistor, this can be placed at R12, R13, R14, and R15.

WRITING TO THE MAIN CONTROL REGISTER

This function allows you to write to and configure the main control register. After configuring the settings you require, click

the **WRITE TO MAIN CONTROL REGISTER** button to write to the device. See Table 11 for main control register functions.

WRITING TO THE SLEW RATE CONTROL REGISTER

The slew rate control register can be accessed from the other options tab (see Figure 15). The slew rate control functions (**Slew Rate Clock** and **Slew Rate Step**) allow you to configure the slew rate on a per-channel basis. After configuring the setting you require, click **WRITE** to write to the device.

Table 10. Slew Rate Register Functions

Option	Description
Slew Rate EN	Enable/disable the slew rate control feature.
Slew Rate Clock	Set the slew clock rate.
Slew Rate Step	Set the step size when slewing.

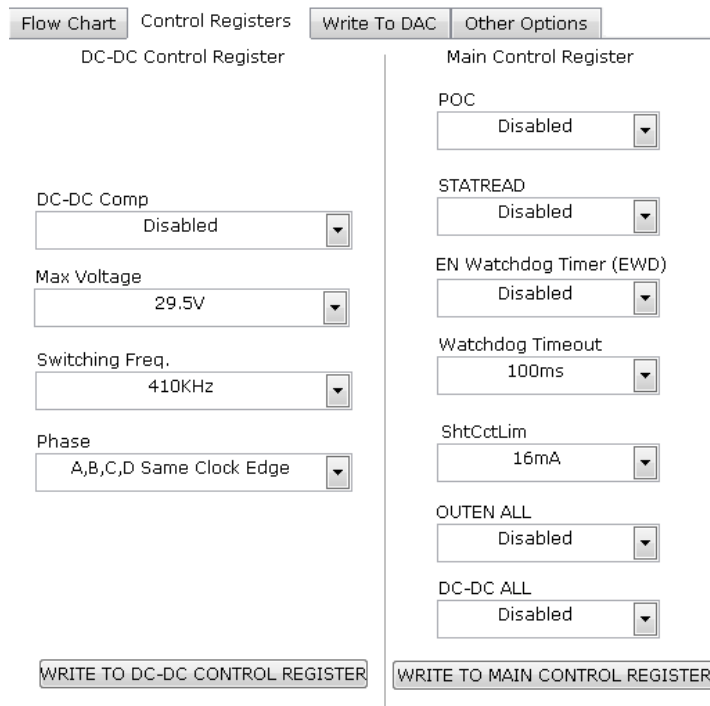

Figure 14. Write to the DC-to-DC Control Register and Main Control Register in the Evaluation Software

Table 11. Main Control Register Functions

Option	Description
POC	Determines the state of the V_{OUT} channel when the voltage output channel is disabled during normal operation. Disabled: disabled V_{OUT} channels goes to the function set by the POC pin. Enabled: disabled V_{OUT} channels goes to the opposite function of the POC pin.
STATREAD	Enable/disable status readback during a write (see the Status Readback section for details about using this feature).
EN Watchdog Timer (EWD)	Enable/disable the watchdog timer (see the Writing to the Main Control Register section for details about using this feature).
Watchdog Timeout	Select timeout period for watchdog timer (using 100 ms or 200 ms with the evaluation software recommended).
ShtCctLim	Selects short-circuit current limit on the V_{OUT} channels.
OUTEN ALL	Enables the output on all four DACs simultaneously. Do not use OUTEN ALL when enabling channels via the DAC control registers.
DC-DC ALL	When set, powers up the dc-to-dc converter on all four channels simultaneously. To power down the dc-to-dc converters, all channels outputs must first be disabled. Do not use the DC-DC ALL option when enabling the dc-to-dc converters via the DAC control registers.

OTHER OPTIONS

Click the **Other Options** tab shown in Figure 15 to access this feature. From this tab, the user can set the slew rate register, PEC, and user toggle bit ([AD5755/AD5757](#) only) that is contained in the status register. A software reset can also be performed.

This tab contains a feature for using the watchdog timer. By entering a value for **Delay (ms)**, the evaluation software attempts to send the SPI code required to the software register (0x195) in approximately the time specified. Note that, because the latency of the USB connection is not strictly defined, this time delay is only a rough estimate but can be far exceeded. It is recommended to use the 100 ms or 200 ms watchdog timeouts when using this feature.

PEC

In packet error checking mode, only 32-bit commands are accepted. This consists of the 24 data bits and an 8-bit frame check calculated using the polynomial:

$$C(x) = x_8 + x_2 + x_1 + 1$$

[AD5755](#) and [AD5757](#)

The [AD5755](#) and [AD5757](#) PEC function is activated by writing 32-bits to the device. The frame check must match the 24 data bits or the command will be ignored.

To activate this feature in the software, ensure that the correct product is selected from the device selection menu (see Figure 8) then click **ENABLE PEC** (see Figure 15).

The software will now perform 32-bit writes to the device.

Clicking **ENABLE PEC** once again will return the software to 24-bit write mode. In this mode, the [AD5755](#) and [AD5757](#) will accept 24-bit writes once again.

[AD5755-1](#)

The [AD5755-1](#) PEC function is activated by enabling the PEC enable bit (Bit 12 in the software register). Once enabled, each command must be 32 bits long.

To activate this feature in the software, ensure that the correct product is selected from the device selection menu (see Figure 8) then click **ENABLE PEC** (see Figure 15).

The PEC enable bit is enabled and software will now perform 32-bit writes to the device. The status of the PEC enable bit can be checked by reading the status register (Bit D11) or utilizing the STATREAD function (see the Status Readback section).

Clicking the PEC enable bit once again will return the software to 24-bit write mode. The PEC enable bit will also be disabled. In this mode, the [AD5755-1](#) will accept 24-bit writes once again.

For more information, refer to the Packet Error Checking section of the respective device data sheets.

STATUS READBACK

When **STATREAD** is enabled (see Figure 14), the status register is displayed shown in Figure 16. Note that the status register readback on a write operation reports any errors present immediately before the current write command.

CLOSING THE SOFTWARE

If the software is closed but the [AD5755/AD5755-1/AD5757](#) and SDP remain powered, the evaluation board will retain the last state set by the software, with the exception of the PEC, which is disabled.

Flow Chart | Control Registers | Write To DAC | **Other Options**

Slew Rate Control Register

Write to Slew Rate Control Register

DACA Slew Rate EN

Slew Rate Step Slew Rate Clock

1 LSB 64KHz

PEC

Data Written Data Read

PEC Written PEC Read

PEC ERROR On Recieve

Watchdog Timer Interval

Delay (ms)

Software Reset

User Toggle Bit

0

Figure 15. Other Options in the Evaluation Software (AD5755/AD5757 Device Selected)

Status Readback

D15	DCDC D	DCDC C	DCDC B	DCDC A	User Toggle	PEC Error	Ramp Active	Over-temp.	VoutD Fault	VoutC Fault	VoutB Fault	VoutA Fault	IoutD Fault	IoutC Fault	IoutB Fault	IoutA Fault	D0
	<input type="checkbox"/>	<input type="checkbox"/>	<input type="checkbox"/>	<input type="checkbox"/>	<input type="checkbox"/>	<input type="checkbox"/>	<input type="checkbox"/>	<input type="checkbox"/>	<input type="checkbox"/>	<input type="checkbox"/>	<input type="checkbox"/>	<input type="checkbox"/>	<input type="checkbox"/>	<input type="checkbox"/>	<input type="checkbox"/>	<input type="checkbox"/>	

Figure 16. Status Readback Indicator (AD5755/AD5757 Device Selected)

EVALUATION BOARD SCHEMATICS AND ARTWORK

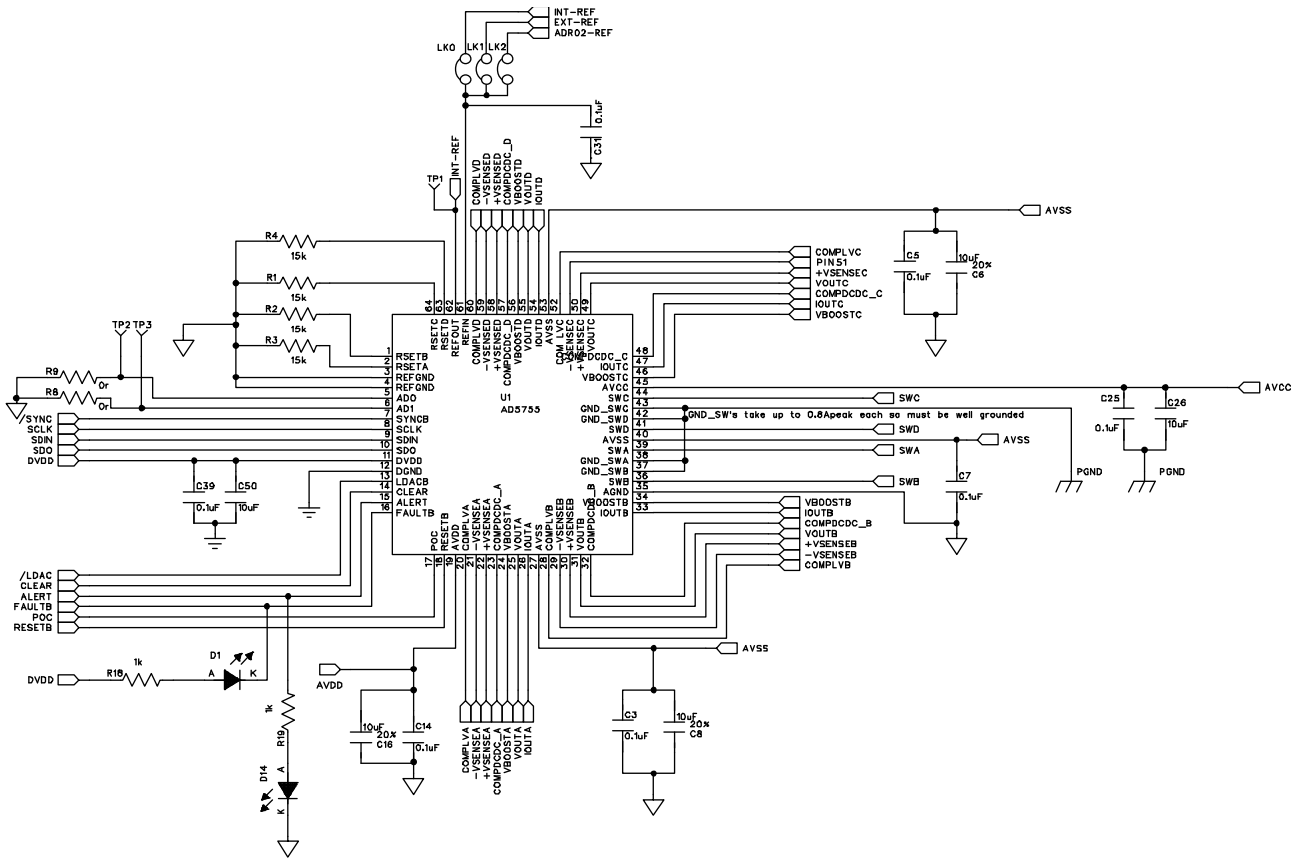

Figure 17. Main Device Circuitry

09633-015

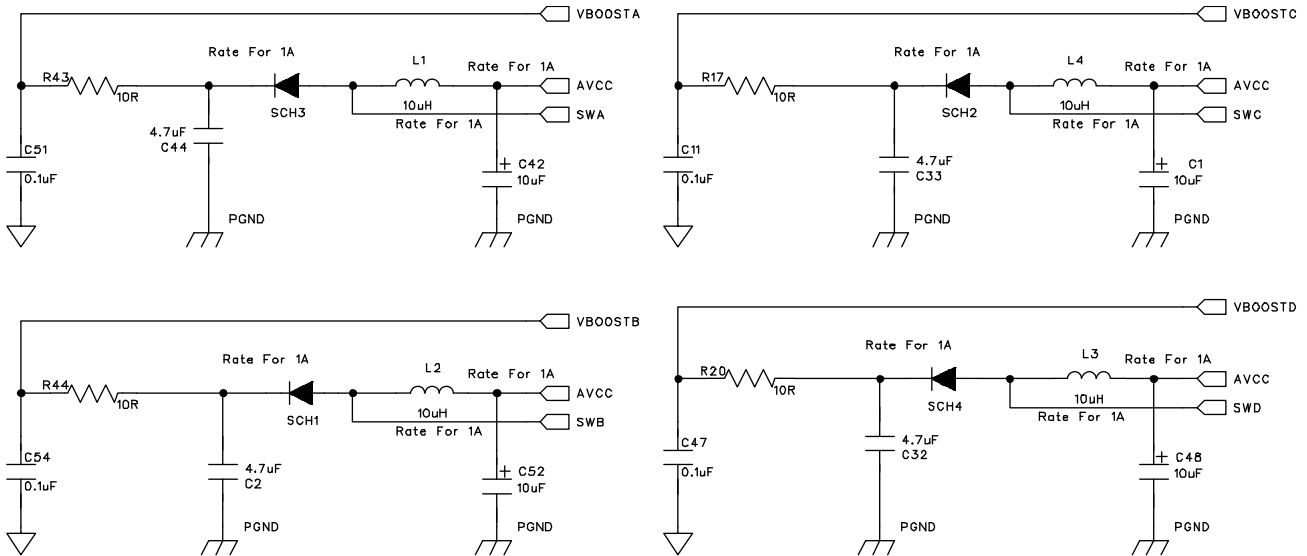

Figure 18. DC-to-DC Circuitry

09633-016

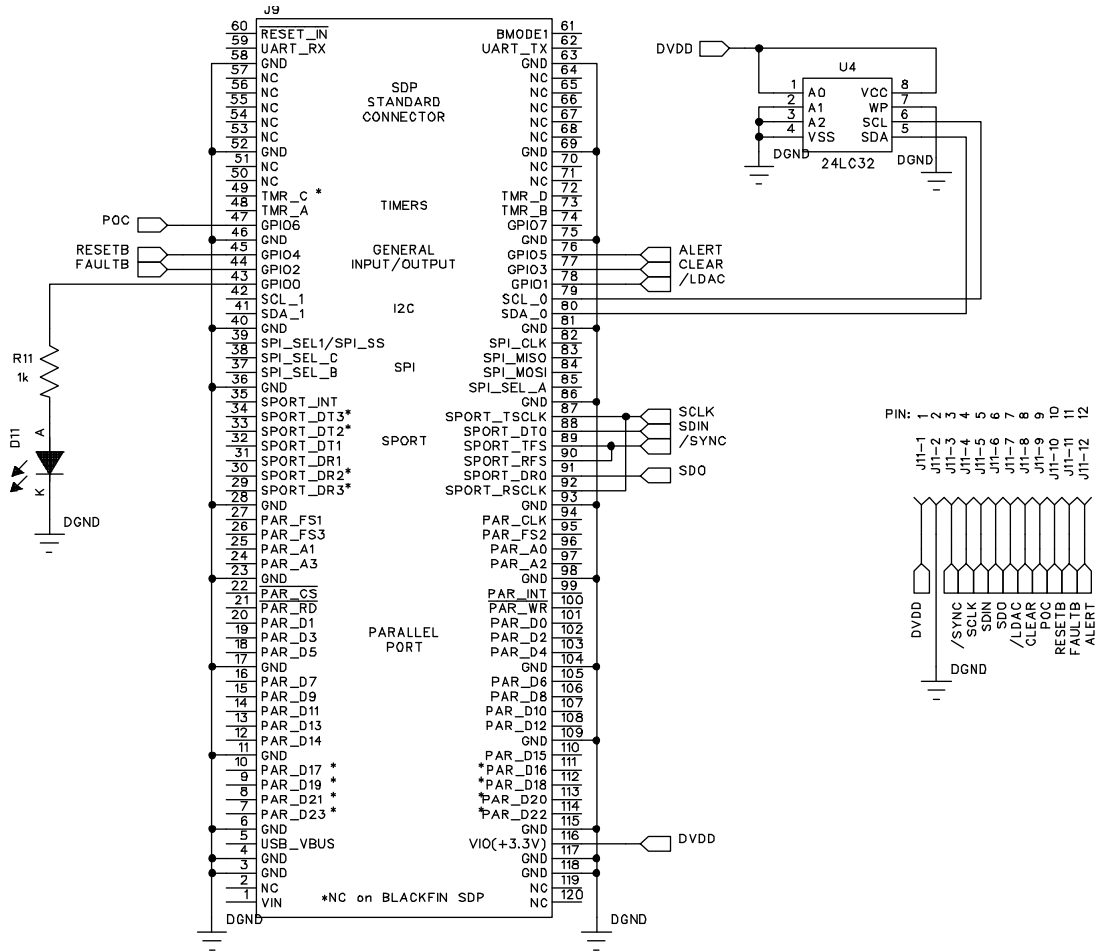

Figure 21. SDP Board Connector

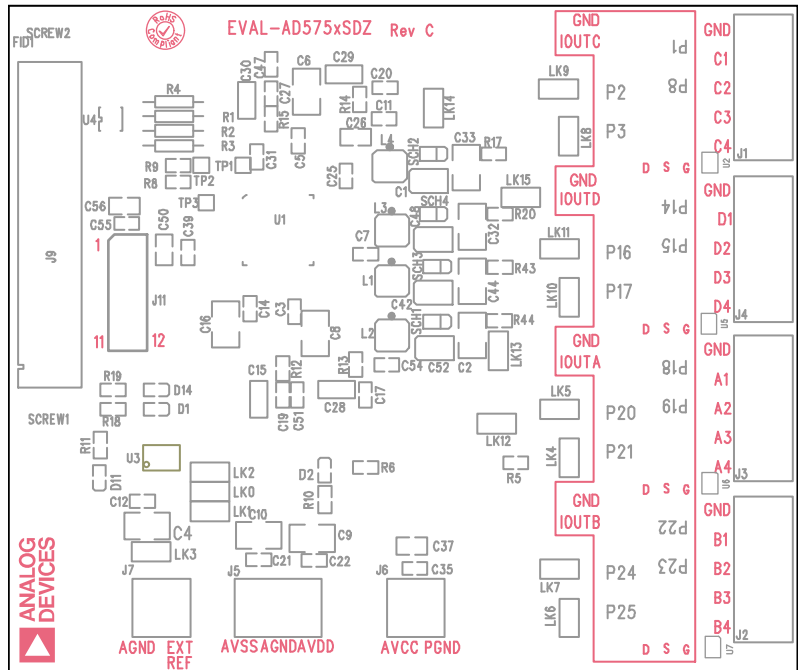
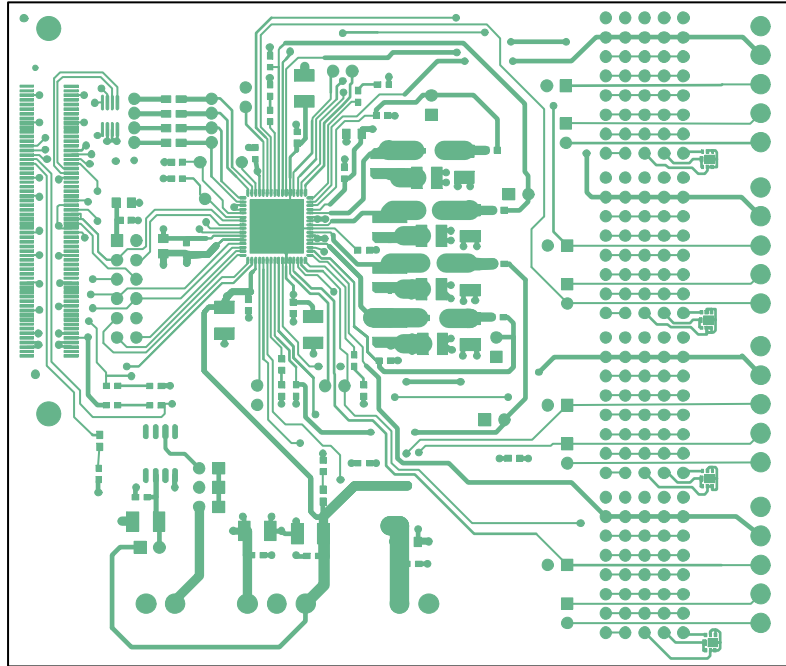
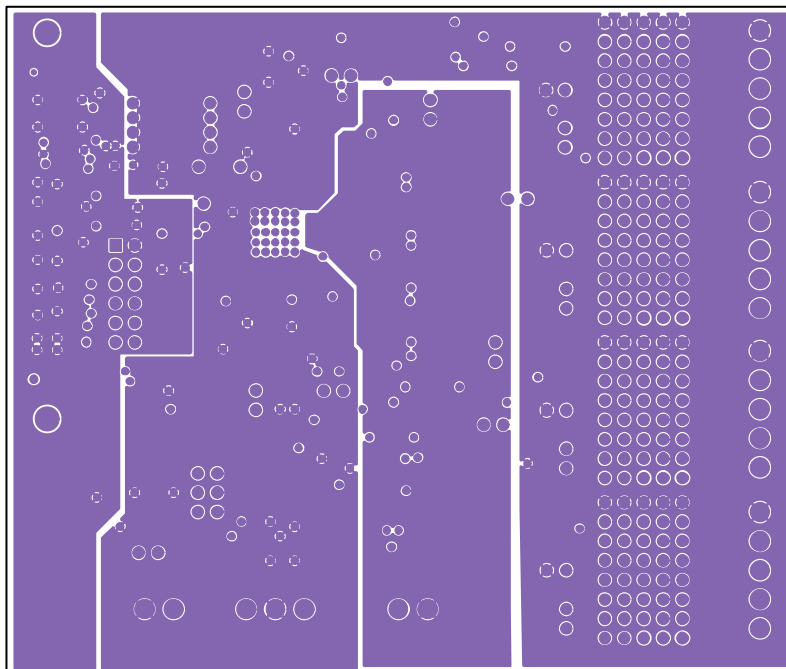

Figure 22. Component Placement



09633-021

Figure 23. Top PCB Layer



09633-022

Figure 24. Inner First PCB Layer

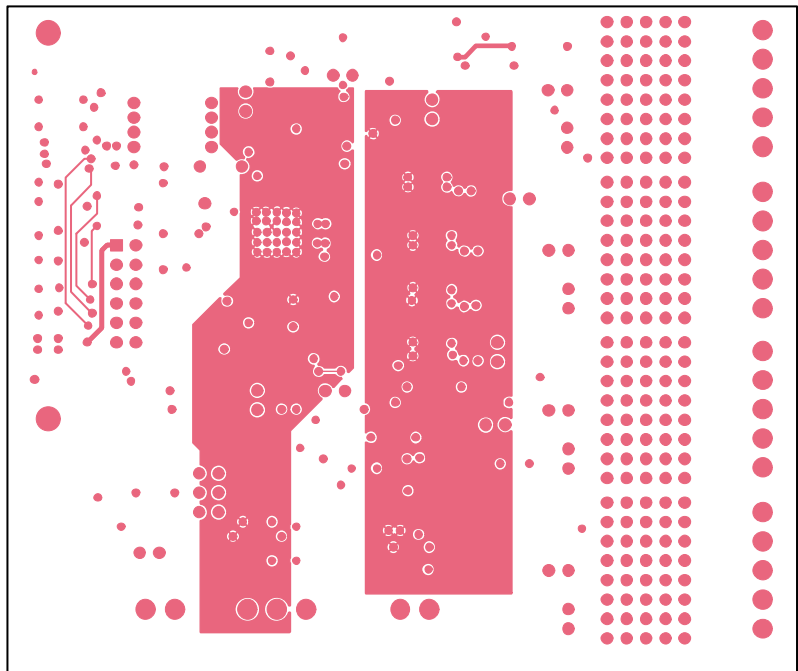

Figure 25. Inner Second PCB Layer

09633-023

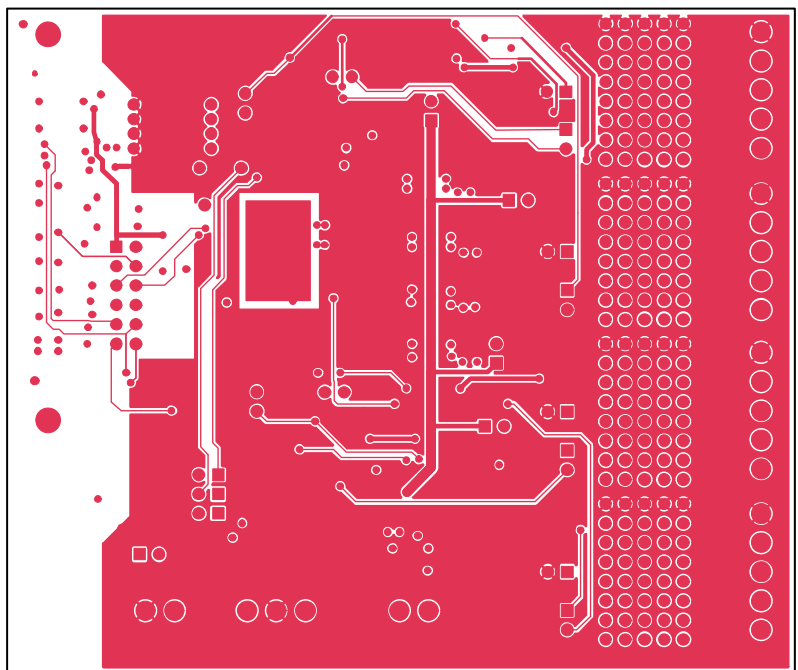

Figure 26. Bottom PCB Layer

09633-024

ORDERING INFORMATION

BILL OF MATERIALS

Table 12.

Qty	Reference Designator	Part Description	Part Number	Stock Code
4	C1, C42, C48, C52	10 μ F, 10 V, SMD tantalum capacitor, Case A	TCJA106M010R0300	FEC 1135234
4	C2, C32, C33, C44	4.7 μ F, 50 V, X7R ceramic capacitor, 1210	GRM32ER71H475KA88L	FEC 1404215
5	C4, C6, C8, C10, C16	10 μ F, 50 V, X5R ceramic capacitor, 1210	UMK325BJ106MM-T	FEC 1683595
17	C3, C5, C7, C9, C11, C12, C14, C21, C22, C25, C31, C35, C39, C47, C51, C54, C55	0.1 μ F, 50 V, X7R ceramic capacitor, 0603	MCRR25101COGJ0100	FEC 1288255
4	C15, C28 to C30	100 pF, 100 V, C0G ceramic capacitor, radial	B37979G1101J	FEC 1216416
4	C17, C19, C20, C27	10 nF, 50 V, X7R ceramic capacitor, 0603	B37931K5103K60	FEC 753622
4	C26, C37, C50, C56	10 μ F, 16 V, X5R ceramic capacitor, 0805	GRM21BR61C106KE15L	FEC 1762635
1	D1	Red, SMD LED, 0603	SML-D12U8WT86	FEC 1685094
3	D2, D11, D14	Green, SMD LED, 0603	SML-512MWT86R	FEC 1685076
4	J1 to J4	5-pin terminal block (3.81 mm pitch)	3704609	FEC 3704609
1	J5	3-pin terminal block (3.81 mm pitch)	1727023	FEC 3704580
2	J6, J7	2-pin terminal block (3.81 mm pitch)	1727010	FEC 3704579
1	J9	120-way connector, 0.6 mm pitch	FX8-120S-SV(21)	FEC 1324660
1	J11	12-pin (2 \times 6) 0.1" pitch header	M20-9980646	FEC 1022238
4	L1 to L4	Inductor	XAL4040-103	Coilcraft XAL4040-103
16	LK0 to L15	2-pin (0.1" pitch) header and jumper socket	M20-9990246	FEC 1022247 and FEC 150411
4	R1, R2, R3, R4	15 k Ω , low drift, SMD resistor, 0805	PCF0805-13-15K-B-T1	FEC 1108896
1	R5	0 Ω , SMD resistor, 0603	CRCW06030000Z0EA	DNP
7	R6, R8, R9, R12, R13, R14, R15	0 Ω , SMD resistor, 0603	CRCW06030000Z0EA	FEC 1469739
1	R10	2.2 k Ω , SMD resistor, 0603	CRCW06032K20JNEA	FEC 1652868
3	R11, R18, R19	1 k Ω , SMD resistor, 0603	CRCW06031K00JNEA	FEC 1652851
4	R17, R20, R43, R44	10 Ω , SMD resistor, 0603	CRCW060310R0FKEA	FEC 1469751
4	SCH1 to SCH4	1 A, 60 V, Schottky diode, POWERDI323	PD3S160-7	FEC 1843697
3	TP1 to TP3	Test point		DNP
1	U1	Quad 16-bit DAC with dynamic power control	AD5755 AD5755-1 AD5757	AD5755BCPZ AD5755-1ACPZ AD5757ACPZ
1	U3	5 V precision reference, 8-lead SOIC	ADR02BRZ	ADR02BRZ
1	U4	32 kB I ² C serial EEPROM, 8-lead MSOP	24LC32A-I/MS	FEC 1331330
4	U2, U5, U6, U7	MOSFET P-channel, 30 V (only populate on EVAL-AD5757 boards)	FDMA530PZ	Digi-Key FDMA530PZCT-ND

RELATED LINKS

Resource	Description
AD5755	Product Page, Quad Channel, 16-Bit, Serial Input, 4 mA to 20 mA and Voltage Output DAC, Dynamic Power Control
AD5757	Product Page, Quad Channel, 16-Bit, Serial Input, 4 mA to 20 mA Output DAC, Dynamic Power Control, HART Connectivity
AD5755-1	Product Page, Quad Channel, 16-Bit, Serial Input, 4 mA to 20 mA and Voltage Output DAC, Dynamic Power Control, HART Connectivity
ADR02	Product Page, Ultracompact, Precision 5.0 V Voltage Reference

