

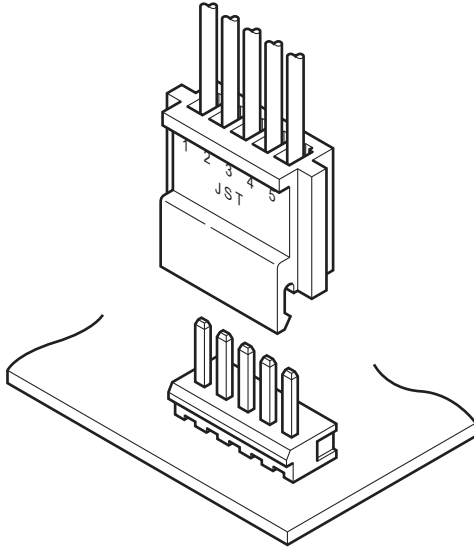

NH CONNECTOR

2.5 mm pitch/Wire-to-Board connectors/Crimp style and Mating style



This is a 2.5 mm pitch connector for connecting PC boards and wires, and consists of a contact, housing and header. There are three types of Header: top, side and bottom entry types, which allow wires to be drawn up, down, or parallel to the PC board by combining them.

■ Features

• Highly reliable leaf spring structure

1. Excellent insertion/extraction performance due to low plastic deformation caused by repeated insertion/extraction.
2. The spring elasticity range is wide and not significantly affected by differences in contact pressure, resulting in stable contact performance.
3. Deformation due to prying hardly occurs.

• Double-sided contact

1. The contact area with the post is contained within the box and there is no risk of damage.
2. The high contact pressure and structure that is not subject to irregular external forces such as prying always maintain good contact with post.
3. Double-sided contact ensures excellent contact reliability and stability.

• Wide, and hard-to-deform post

The mating side of the post is wider and has a larger cross-sectional area, which improves deformation resistance to irregular external forces such as prying.

• Insert molding

The header is an insert molded product to completely prevent the post shifting from the wafer or flux creeping up along the post.

■ Standards

Ⓡ : Recognized E 60389

Ⓢ : Certified LR 20812

△ : J50168090

■ Specifications

- Current rating: 3 A AC/DC (AWG #22)
 - Voltage rating: 250 V AC/DC
 - Temperature range: -25°C to +85°C
(including temperature rise in applying electrical current)
 - Contact resistance:
Initial value/ 15 mΩ max.
After environmental tests/ 20 mΩ max.
 - Insulation resistance: 500 MΩ min.
 - Withstanding voltage:
There shall be no breakdown or flashover while applying 1,500 VAC for one minute.
 - Applicable wire range:
Conductor size/ AWG #30 to AWG #22
Insulation O.D. / ϕ 0.9 mm to ϕ 1.7 mm
 - Applicable PC board thickness: 1.6 mm
- * In using the products, refer to "Handling Precautions for Terminals and Connectors" described on our website (Technical documents of Product information page).
- * RoHS2 compliance
- * Dimensional unit: mm
- * Contact JST for details.

NH CONNECTOR

Contact

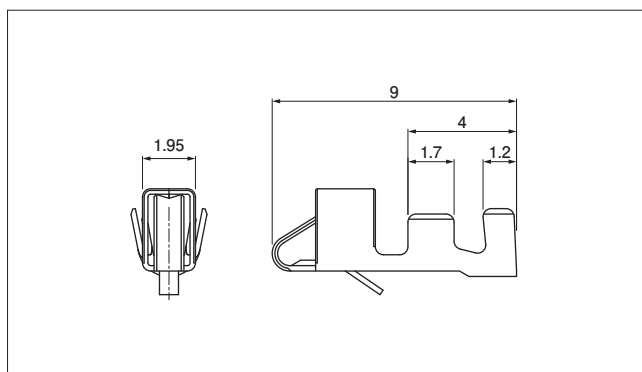

Model No.	Applicable wire range		Q'ty/ reel
	Conductor size AWG (mm ²)	Insulation O.D. (mm)	
SHF-002T-0.8BS	#30 to #28 (0.05 to 0.08)	0.9 to 1.2	5,000
SHF-001T-0.8BS	#28 to #22 (0.08 to 0.33)	1.2 to 1.7	

Material and Surface finish, etc.

Phosphor bronze, tin-plated

- Note: 1. Contact JST for gold-plated products.
 2. Also contact JST if you require shielded wires, thin wires or other special wires.

Housing

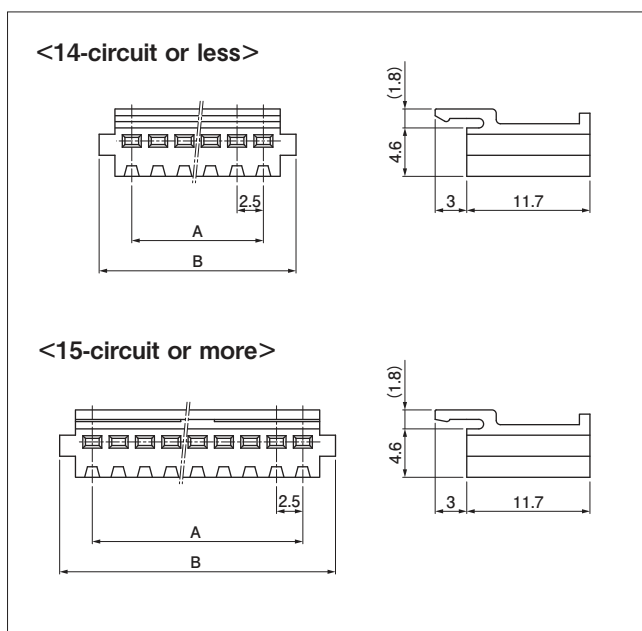

No. of circuits	Model No.	Dimensions (mm)		Q'ty/bag
		A	B	
2	H2P-SHF-AA	2.5	8.7	1,000
3	H3P-SHF-AA	5.0	11.2	1,000
4	H4P-SHF-AA	7.5	13.7	1,000
5	H5P-SHF-AA	10.0	16.2	1,000
6	H6P-SHF-AA	12.5	18.7	1,000
7	H7P-SHF-AA	15.0	21.2	500
8	H8P-SHF-AA	17.5	23.7	500
9	H9P-SHF-AA	20.0	26.2	500
10	H10P-SHF-AA	22.5	28.7	500
11	H11P-SHF-AA	25.0	31.2	500
12	H12P-SHF-AA	27.5	33.7	500
13	H13P-SHF-AA	30.0	36.2	500
14	H14P-SHF-AA	32.5	38.7	500
15	H15P-SHF-AA	35.0	41.2	200
16	H16P-SHF-AA	37.5	43.7	200
18	H18P-SHF-AA	42.5	48.7	200
20	H20P-SHF-AA	47.5	53.7	200
21	H21P-SHF-AA	50.0	56.2	200
22	H22P-SHF-AA	52.5	58.7	200
24	H24P-SHF-AA	57.5	63.7	200
25	H25P-SHF-AA	60.0	66.2	200

Material and Surface finish, etc.

PA 6, UL94V-0, natural

Header

Top entry type

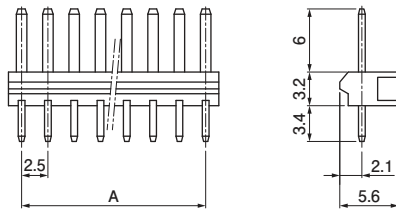

Side entry type

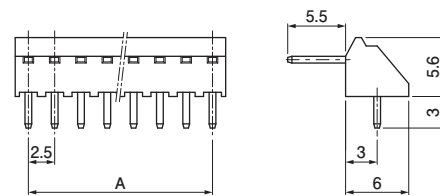

Bottom entry type

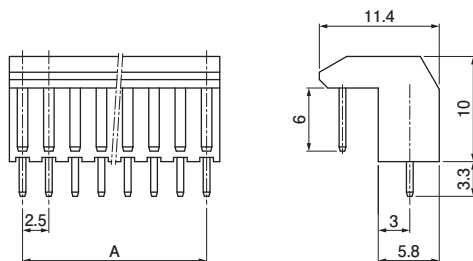

No. of circuits	Model No.			Dimension A (mm)	Q'ty/box		
	Top entry type	Side entry type	Bottom entry type		Top entry type	Side entry type	Bottom entry type
2	B2P-SHF-1AA	BS2P-SHF-1AA	BE2P-SHF-1AA	2.5	1,000	1,000	250
3	B3P-SHF-1AA	BS3P-SHF-1AA	BE3P-SHF-1AA	5.0	1,000	1,000	250
4	B4P-SHF-1AA	BS4P-SHF-1AA	BE4P-SHF-1AA	7.5	1,000	500	250
5	B5P-SHF-1AA	BS5P-SHF-1AA	BE5P-SHF-1AA	10.0	1,000	500	250
6	B6P-SHF-1AA	BS6P-SHF-1AA	BE6P-SHF-1AA	12.5	500	500	150
7	B7P-SHF-1AA	BS7P-SHF-1AA	BE7P-SHF-1AA	15.0	500	500	150
8	B8P-SHF-1AA	BS8P-SHF-1AA	BE8P-SHF-1AA	17.5	500	500	150
9	B9P-SHF-1AA	BS9P-SHF-1AA	BE9P-SHF-1AA	20.0	500	500	150
10	B10P-SHF-1AA	BS10P-SHF-1AA	BE10P-SHF-1AA	22.5	250	250	100
11	B11P-SHF-1AA	BS11P-SHF-1AA	BE11P-SHF-1AA	25.0	250	250	100
12	B12P-SHF-1AA	BS12P-SHF-1AA	BE12P-SHF-1AA	27.5	250	200	100
13	B13P-SHF-1AA	BS13P-SHF-1AA	—	30.0	250	200	—
14	B14P-SHF-1AA	BS14P-SHF-1AA	—	32.5	250	200	—
15	B15P-SHF-1AA	BS15P-SHF-1AA	—	35.0	250	200	—
16	B16P-SHF-1AA	BS16P-SHF-1AA	—	37.5	250	200	—
17	B17P-SHF-1AA	BS17P-SHF-1AA	—	40.0	200	200	—
18	B18P-SHF-1AA	BS18P-SHF-1AA	—	42.5	200	200	—
19	—	BS19P-SHF-1AA	—	45.0	—	200	—
20	B20P-SHF-1AA	BS20P-SHF-1AA	—	47.5	250	200	—
21	B21P-SHF-1AA	BS21P-SHF-1AA	—	50.0	250	200	—
22	B22P-SHF-1AA	BS22P-SHF-1AA	—	52.5	250	200	—
23	—	BS23P-SHF-1AA	—	55.0	—	200	—
24	B24P-SHF-1AA	BS24P-SHF-1AA	—	57.5	250	200	—
25	B25P-SHF-1AA	BS25P-SHF-1AA	—	60.0	250	200	—

Material and Surface finish, etc.

Post: Brass, copper-undercoated, tin-plated
 Wafer: Top and side entry types/ PA 66, UL94V-0, natural
 Bottom entry type/ PA 6, UL94V-0, natural

Note: This product displays (LF)(SN) on a label.

PC board layout and Assembly layout

Top entry type

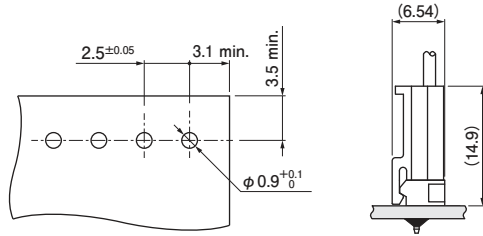

Side entry type

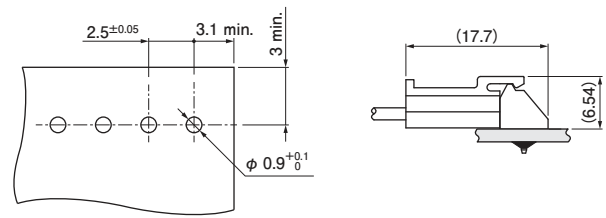

Bottom entry type

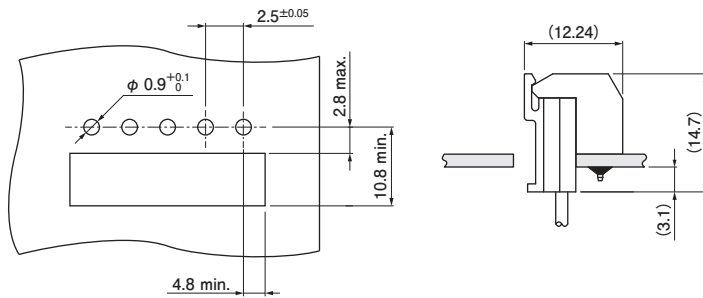

- Note: 1. The figure of PC board layout is the figure viewed from the connector mounting side.
 2. Tolerance for the PCB hole pitch shall be ± 0.05 , and shall not accumulate.
 3. Hole dimensions differ according to the type of PC board and piercing method.
 The above dimensions are reference values. Please contact JST for details.

Model number allocation

Contact

	S HF - 001 T - 0.8 BS
Supply form: Strip form	
Series name	
Applicable wire range:	
002...AWG #30 to AWG #28	
001...AWG #28 to AWG #22	
Surface finish: Tin-plated	
Applicable post size	
Material: Phosphor bronze	

Housing

	H 2 P - SHF - AA -
Pitch: 2.5 mm	
No. of circuits	
Type: Plug	
Series name	
Flammability: UL94V-0	
Color: Blank...Natural, K...Black, R...Red, E...Blue, M...Green, Y...Yellow, H...Gray	

Header

	B 3P - SHF - 1AA -
Header type:	
B...Top entry type	
BS...Side entry type	
BE...Bottom entry type	
No. of circuits	
Series name	
Flammability: UL94V-0	
Clinched (Kinked) / Not clinched: Blank...Straight K...Clinched	
Color: Blank...Natural, BK...Black, R...Red, E...Blue, Y...Yellow	

Crimping machine, Applicator

Contact	Crimping machine	Applicator	Crimp applicator with dies
SHF-002T-0.8BS	AP-K2N	MKS-L	APLMK SHF002-08S
SHF-001T-0.8BS			APLMK SHF001-08S

Note: Contact JST for fully automatic crimping applicator.