

EL Shield

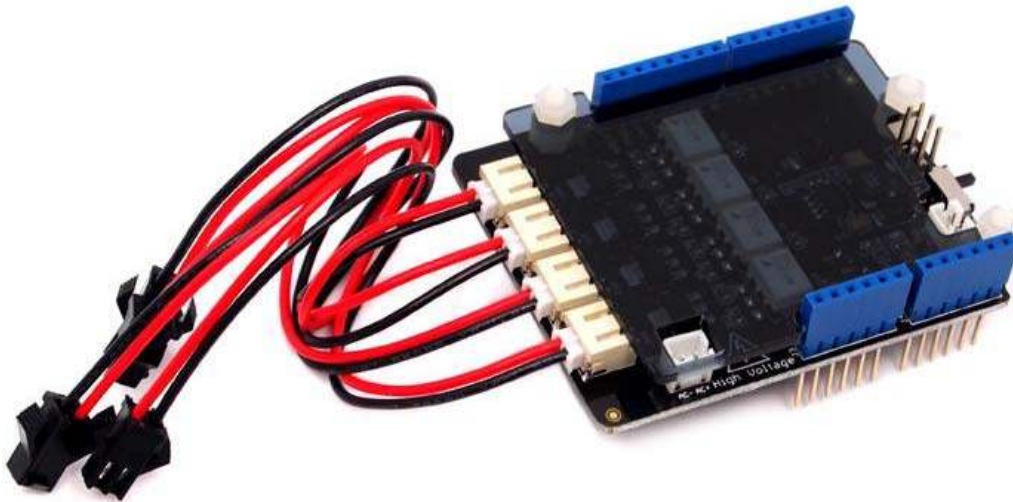

This shield is used to control EL devices. It can control 4 EL devices simultaneously. The controlling method is as simple as controlling an LED. Driven by PWM, it can create a colorful and florid effect by controlling each EL wire with a simple program. Combined with our EL Inverter, it can drive an EL wire as long as 15m, which provides infinite possibility for your design. Besides, the Shield is covered by Acrylic board, which enhances user's safety.

Specifications

- Operating Voltage: 5V
- Inverter interface: JST 2.0
- Control channel interface: 2P - 2.5SM socket

Compatibility

We have produced a lot of extension board that can make your platform board more powerful, however not every extension board is compatible with all the platform board, here we use a table to illustrate how are those boards compatible with platform board.

Note

Please note that "Not recommended" means that it might have chance to work with the platform board however requires extra work such as jump wires or rewriting the code. If you are interested in digging more, welcome to contact with techsupport@seeed.cc.

	Arduino Uno Seeeduno v4.2	Arduino Mega Seeeduno Mega	Zero(m0) LoraWAN	Arduino Leonardo Seeeduno Lite	Arduino 101	Arduino Due 3.3v	Intel Edison 5v	Linkit One
2.8" TFT Touch Shield V2.0	not support	not support	Not recommended	not support	Not recommended	Not recommended	Not recommended	Not recommended
Base Shield V2	Yes	Yes	Yes	Yes	Yes	Yes	Yes	Yes
Camera Shield	Only Pin234567	Hardware Serial OK	Not recommended	Not recommended	Yes	Hardware Serial OK	No	No
EL Shield	Yes	Yes	No	Yes	No	No	No	No
Energy Shield	Yes	Yes	Yes	Yes	Yes	Yes	Yes	No
GPS Shield	Not recommended	Not recommended	Yes	Yes	Yes	Not recommended	Yes	No need
Motor Shield V2.0	Yes	Stepper motor only	No	Yes	Stepper motor only	Stepper motor only	No	No
Music Shield V2.0	Yes	Yes	Not recommended	Yes	Yes	Yes	Yes	Yes
NFC Shield V2.0	Yes	Yes	Yes	Yes	Yes	Yes	No	Yes
Protoshield Kit for Arduino	Yes	Yes	Yes	Yes	Yes	Yes	Yes	Yes
RS232 Shield	Yes	Yes	No	Yes	No	No	No	No
Relay Shield V3.0	Yes	Yes	Yes	Yes	Yes	Yes	Yes	Yes
SD Card Shield V4.0	Yes	Yes	Not recommended	Yes	Yes	Yes	No	No
Seed BLE Shield V1	Yes	Not recommended	Not recommended	Yes	No need	Not recommended	Not recommended	No need
W5500 Ethernet Shield	Yes	Yes	Yes	Yes	Yes	Yes	Yes	Yes
Wifi Shield(Fi250) V1.1	Not recommended	Not recommended	Not recommended	Yes	Yes	Not recommended	No need	No need
Wifi Shield V2	Yes	Not recommended	Not recommended	Yes	Yes	Not recommended	No need	No need
XBee Shield V2	Yes	Not recommended	Not recommended	Yes	Yes	Not recommended	Not recommended	Not recommended

Hardware Overview

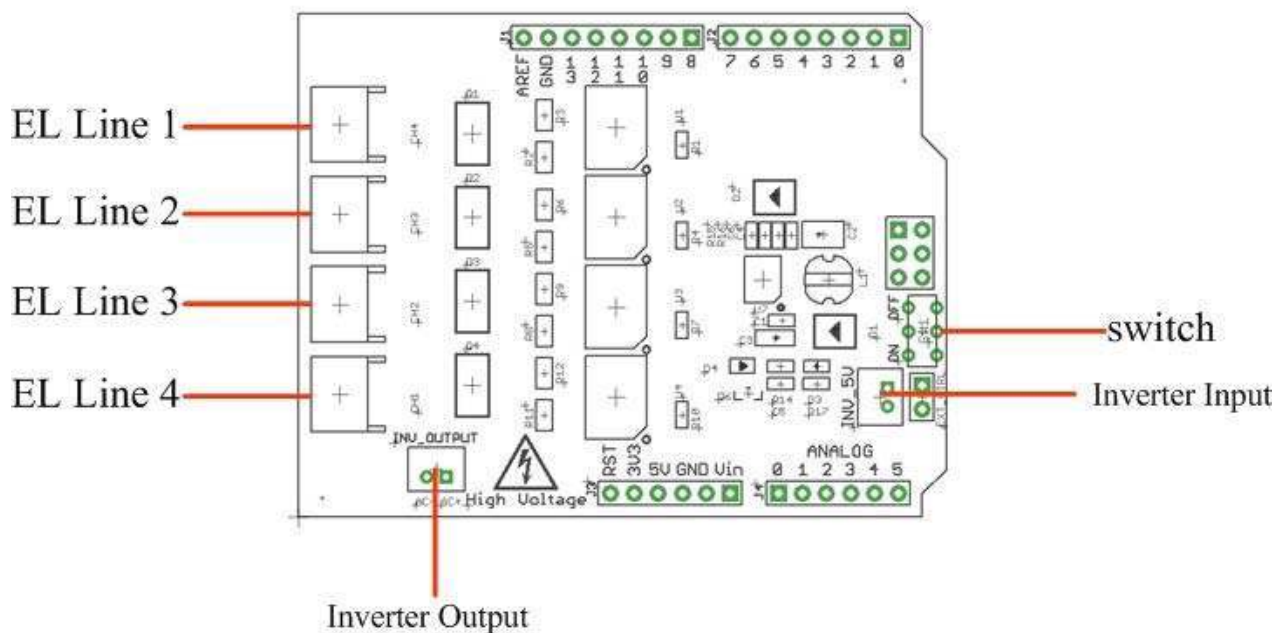

Demonstration

Here is a simple demo involving EL shield, 4 EL tapes and the custom inverter that accompanies EL shield. Hook all things up as in the picture below.

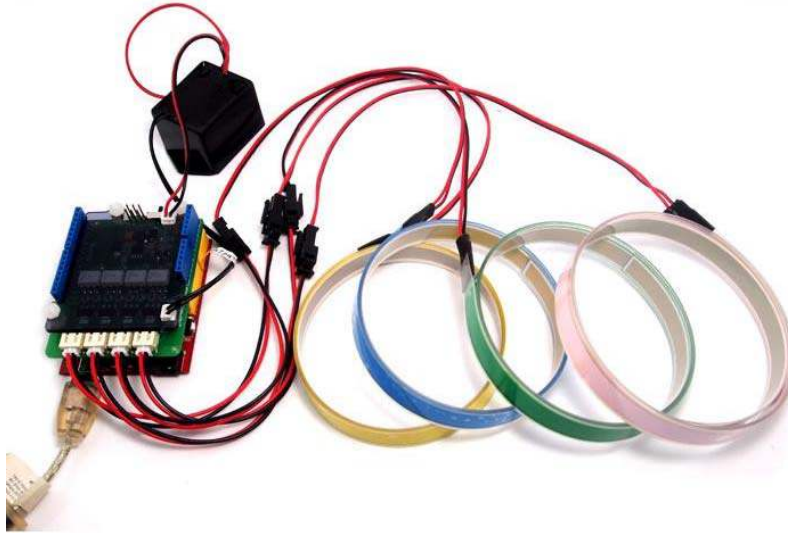

Upload the code below to your microcontroller.

```
1 // EL test code
2
3 void setup(){
4   for(int i = 4; i<8; i++)
5   {
6     pinMode(i, OUTPUT);
7   }
8 }
9
10 void setEL(int ch) // set a certain EL on
11 {
12   for(int i = 4; i<8; i++) // all off
13     digitalWrite(i, LOW);
14   digitalWrite(ch+3, HIGH); // ch on
15 }
16
17 int count = 0;
18
19 void loop()
20 {
21   setEL(count%4 + 1);
22   delay(200);
23   if(count++ == 1000)
24   {
25     count = 0;
26   }
27 }
```

Tech Support

Please submit any technical issue into our forum or drop mail to techsupport@seeed.cc.