

PART NUMBER	LENGTH (METERS)	TOLERANCE (METERS)	PART NUMBER	LENGTH (METERS)	TOLERANCE (METERS)
106410-1001	1*	+0.1/-0.0	106410-1023	23	+0.5/-0.0
106410-1201	15*	+0.1/-0.0	106410-1024	24	+0.5/-0.0
106410-1002	2*	+0.2/-0.0	106410-1025	25	+0.5/-0.0
106410-1202	2.5*	+0.2/-0.0	106410-1026	26	+0.5/-0.0
106410-1003	3*	+0.3/-0.0	106410-1027	27	+0.5/-0.0
106410-1004	4	+0.4/-0.0	106410-1028	28	+0.5/-0.0
106410-1005	5	+0.5/-0.0	106410-1029	29	+0.5/-0.0
106410-1006	6	+0.5/-0.0	106410-1030	30	+0.5/-0.0
106410-1007	7	+0.5/-0.0	106410-1031	31	+1.0/-0.0
106410-1008	8	+0.5/-0.0	106410-1034	34	+1.0/-0.0
106410-1009	9	+0.5/-0.0	106410-1040	40	+1.0/-0.0
106410-1010	10	+0.5/-0.0	106410-1050	50	+1.0/-0.0
106410-1011	11	+0.5/-0.0	106410-1055	55	+1.0/-0.0
106410-1012	12	+0.5/-0.0	106410-1070	70	+1.0/-0.0
106410-1013	13	+0.5/-0.0	106410-1075	75	+1.0/-0.0
106410-1014	14	+0.5/-0.0	106410-1100	100	+1.0/-0.0
106410-1015	15	+0.5/-0.0	106410-1150	150	+1.0/-0.0
106410-1016	16	+0.5/-0.0	106410-1180	180	+1.0/-0.0
106410-1017	17	+0.5/-0.0	106410-1200	200	+1.0/-0.0
106410-1018	18	+0.5/-0.0	106410-1250	250	+1.0/-0.0
106410-1019	19	+0.5/-0.0	106410-1300	300	+1.0/-0.0
106410-1020	20	+0.5/-0.0	106410-1500	500	+1.0/-0.0
106410-1021	21	+0.5/-0.0	106410-2500	1500	+1.0/-0.0
106410-1022	22	+0.5/-0.0	106410-3000	2000	+1.0/-0.0

* FOR CABLES 3 METERS OR LESS, ONE SPLICE PROTECTOR LOCATED APPROXIMATELY IN THE MIDDLE OF CABLE MAY BE USED.

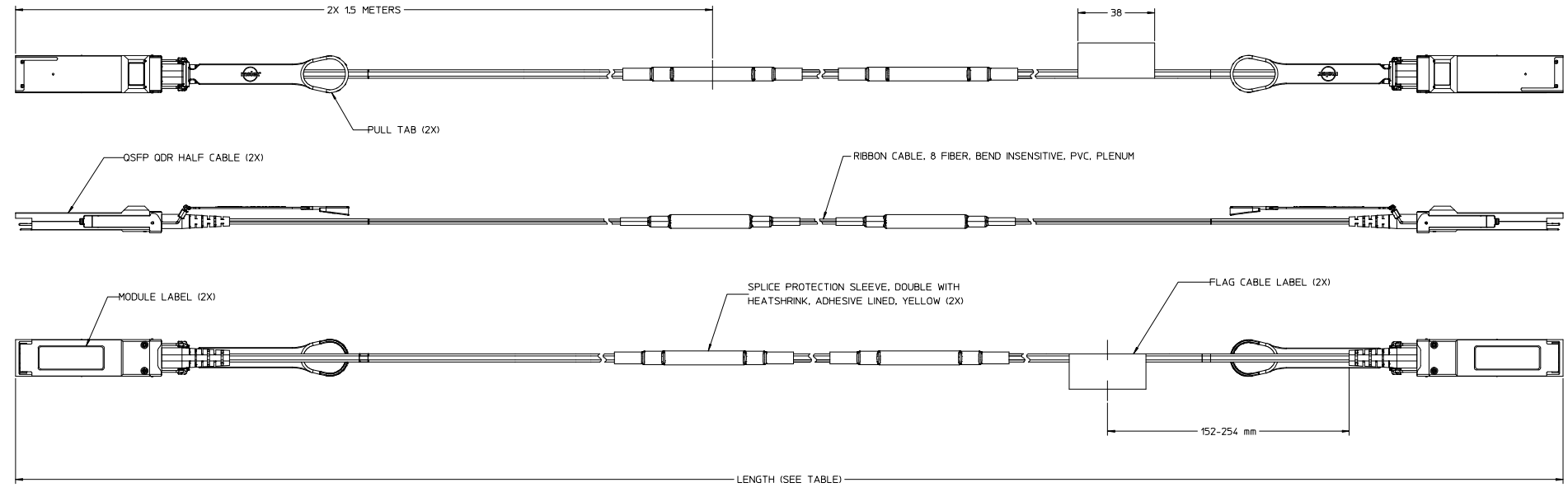

- NOTE:
1. MODULES MEET SFF-8436 SPECIFICATION
 2. ACTIVE OPTICAL CABLE USER INFORMATION IS INCLUDED IN EACH SHIPPING BOX.

ENTER DESCRIPTION IEC NO: NF-2015-0576 DRAWN BY: DRWNAGHARE CHKD: APPR: VEENYAK 2015/03/20	QUALITY SYMBOLS	GENERAL TOLERANCES (UNLESS SPECIFIED)	DIMENSION STYLE	SCALE	DESIGN UNITS	THIRD ANGLE PROJECTION
	▽=0	4 PLACES # --- # ---	MM ONLY	1:1	METRIC	
	▽=0	3 PLACES # --- # ---				
	▽=0	2 PLACES # --- # ---				
		ANGULAR ±1/2°	DRAWN BY	DATE	TITLE	
		DRAFT WHERE APPLICABLE MUST REMAIN WITHIN DIMENSIONS	EEFUNG	2011/09/21	QSFP ODR CABLE	
			CHECKED BY	DATE		
			APPROVED BY	DATE		
			MATERIAL NO.	DOCUMENT NO.		
			SEE TABLE	SD-106410-1001		
			SIZE			
			THIS DRAWING CONTAINS INFORMATION THAT IS PROPRIETARY TO MOLEX INCORPORATED AND SHOULD NOT BE USED WITHOUT WRITTEN PERMISSION			
						SHEET NO. 1 OF 2

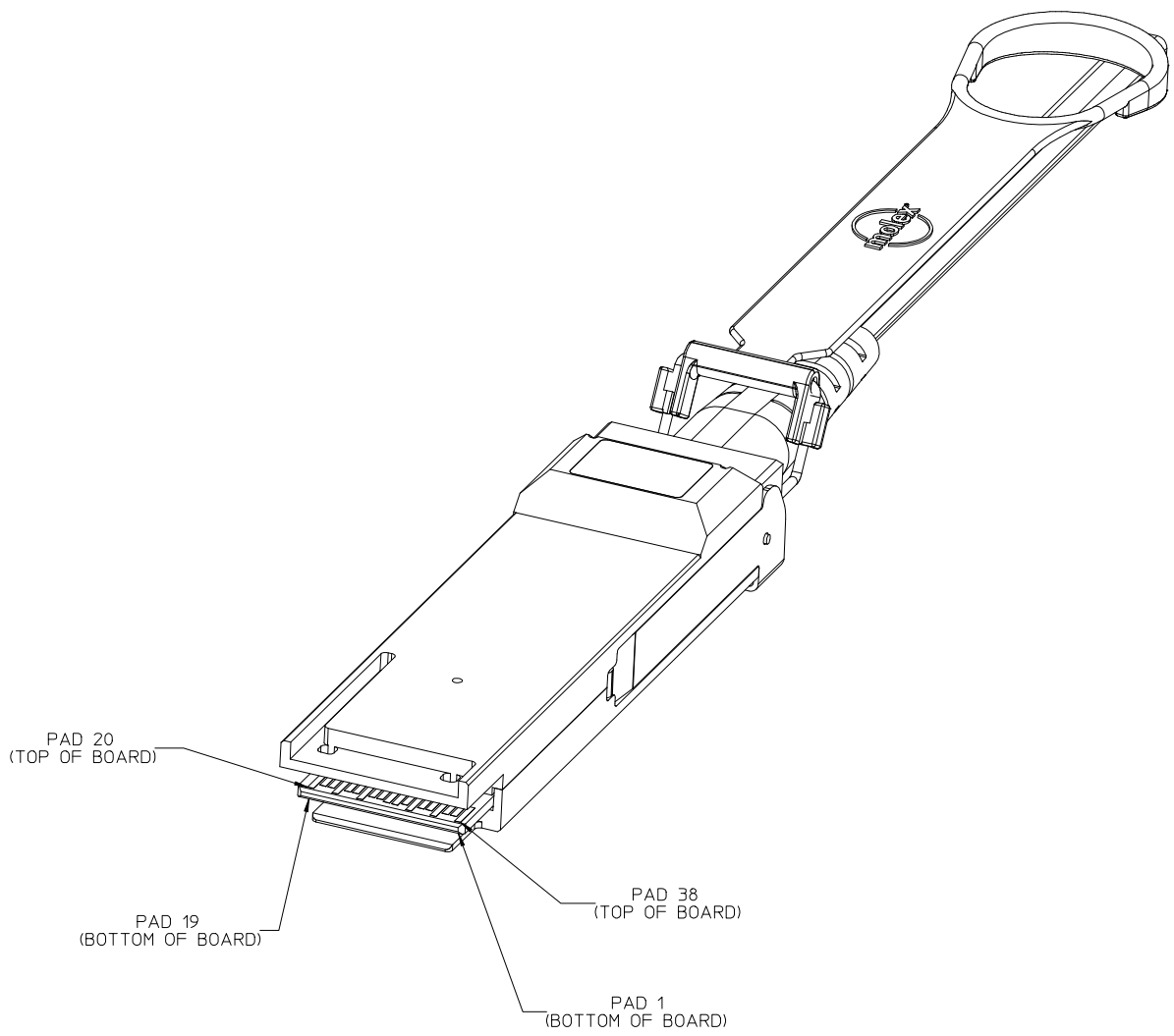

BOTTOM CONTACTS		TOP CONTACTS	
PCB PAD NO.	FUNCTION	PCB PAD NO.	FUNCTION
1	GND	20	GND
2	Tx2n	21	Rx2n
3	Tx2p	22	Rx2p
4	GND	23	GND
5	Tx4n	24	Rx4n
6	Tx4p	25	Rx4p
7	GND	26	GND
8	ModSell	27	ModPrsL
9	ResetL	28	IniL
10	Vcc Rx	29	Vcc Tx
11	SCL	30	Vcc1
12	SDA	31	LPMode
13	GND	32	GND
14	Rx3p	33	Tx3p
15	Rx3n	34	Tx3n
16	GND	35	GND
17	Rx1p	36	Tx1p
18	Rx1n	37	Tx1n
19	GND	38	GND

ENTER DESCRIPTION EC NO: MF2015-0576 DRW: MAGHAYERE 2015/03/25 CHKD: APPR: YBEDNYAK 2015/03/30	QUALITY SYMBOLS ▽=0 ▽=0 ▽=0	GENERAL TOLERANCES (UNLESS SPECIFIED) <table border="1"> <tr><th></th><th>mm</th><th>INCH</th></tr> <tr><td>4 PLACES</td><td>± ---</td><td>± ---</td></tr> <tr><td>3 PLACES</td><td>± ---</td><td>± ---</td></tr> <tr><td>2 PLACES</td><td>± ---</td><td>± ---</td></tr> <tr><td>1 PLACE</td><td>± ---</td><td>± ---</td></tr> <tr><td>0 PLACE</td><td>± ---</td><td>± ---</td></tr> </table>		mm	INCH	4 PLACES	± ---	± ---	3 PLACES	± ---	± ---	2 PLACES	± ---	± ---	1 PLACE	± ---	± ---	0 PLACE	± ---	± ---	DIMENSION STYLE MM ONLY DRAWN BY DATE EEFUNG 2011/09/21 CHECKED BY DATE APPROVED BY DATE	SCALE 1:1 DESIGN UNITS METRIC THIRD ANGLE PROJECTION	TITLE QSFP QDR CABLE
		mm	INCH																				
	4 PLACES	± ---	± ---																				
	3 PLACES	± ---	± ---																				
	2 PLACES	± ---	± ---																				
1 PLACE	± ---	± ---																					
0 PLACE	± ---	± ---																					
MATERIAL NO. SEE SHEET 1	DOCUMENT NO. SD-106410-1001	SHEET NO. 2 OF 2																					
DRAFT WHERE APPLICABLE MUST REMAIN WITHIN DIMENSIONS			THIS DRAWING CONTAINS INFORMATION THAT IS PROPRIETARY TO MOLEX INCORPORATED AND SHOULD NOT BE USED WITHOUT WRITTEN PERMISSION																				
ANGLAR ±1/2°																							
SIZE C																							