

THIS DRAWING IS UNPUBLISHED. RELEASED FOR PUBLICATION  
 © COPYRIGHT 19 BY TYCO ELECTRONICS CORPORATION. ALL RIGHTS RESERVED.

LOC	DIST	REVISIONS					
CE	00	P	LTR	DESCRIPTION	DATE	DWN	APVD
			K	REVISED PER 0A00-0254-02	03APR2002	TA	BE
			L	REVISE PER 0A00-0327-04	15SEP04	KG	DK
			M	REVISE PER 0A00-0601-04	10FEB05	KG	DK
			N	REVISE PER ECR-05-005983	26JUL2005	BB	DK

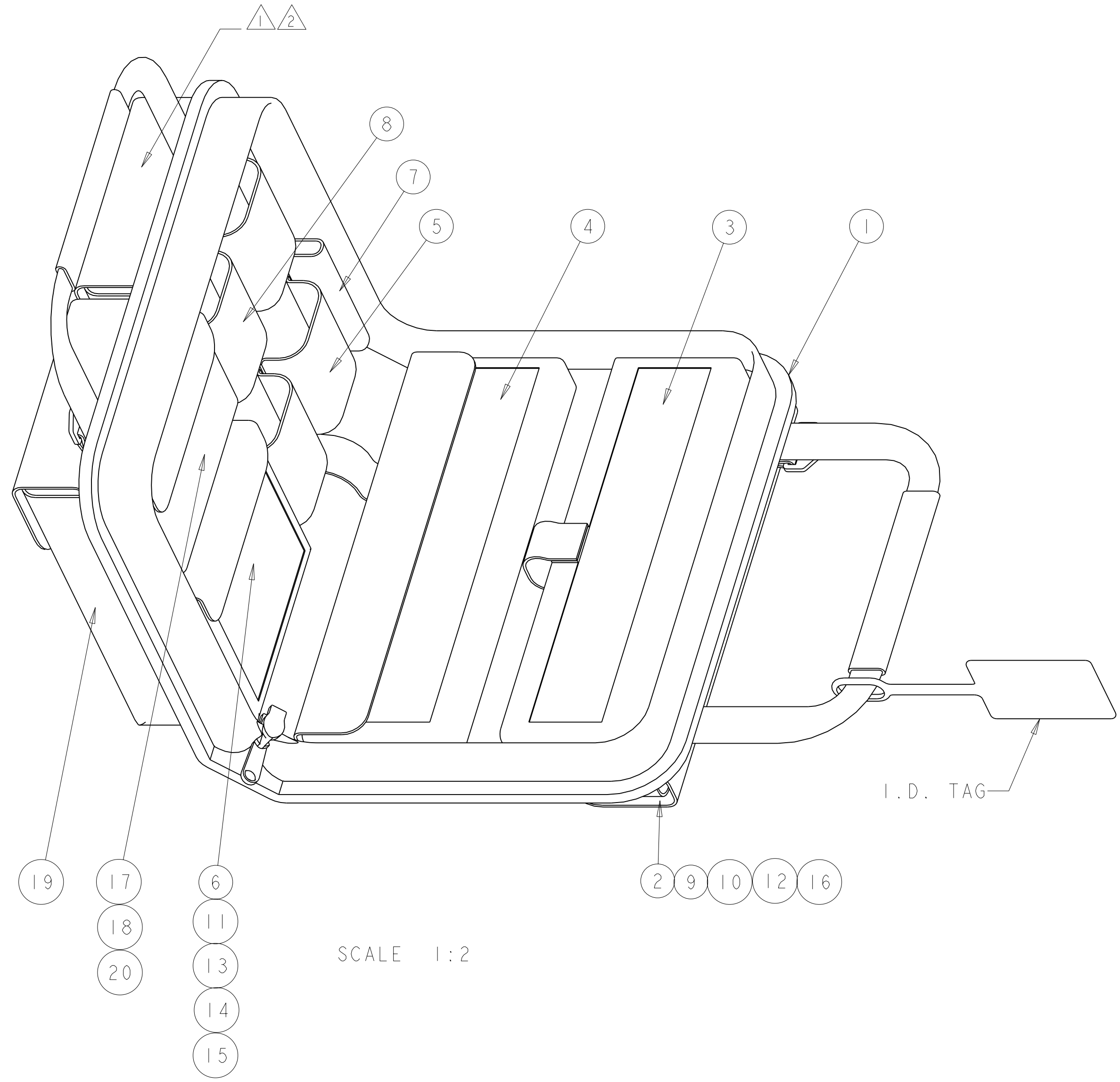

- △ AMP INSTRUCTION SHEETS AND MANUFACTURERS' INSTRUCTION SHEETS
- △ OPTIONAL SHOULDER STRAP.

SUPERCEDED BY:  
503957-3

14	14	14	ALCOHOL FIBER WIPE	501857-2	20
1	1	-	MICROSCOPE W/10X OBJECTIVE	1754767-1	19
1	1	1	CABLE PREP TEMPLATE (XTC/NeXTC)	503574-1	18
1	1	1	CABLE PREP TEMPLATE (AMP LC SC)	503694-1	17
1	1	1	PAD, POLISH (RECTANGULAR)	504584-1	16
1	1	1	BUSHING, POLISHING, METAL SC	503787-1	15
1	1	1	BUSHING, POLISHING, METAL ST	503337-1	14
1	1	1	BUSHING, POLISHING, BLACK PLASTIC	503304-1	13
1	1	1	POLISHING PAD, CIRCULAR	501523-1	12
2	2	2	BUSHING, POLISHING, PLASTIC SC	502631-1	11
10	10	10	LAPPING FILM, 5um	228433-8	10
10	10	10	LAPPING FILM, .3um	228433-5	9
1	1	1	STRIP TOOL, FIBER, COMBO	1754708-1	8
2	2	2	WRENCH, 1/4 OPEN END	1278422-1	7
1	1	1	CLEAVE TOOL, UNIVERSAL	503705-1	6
1	1	1	KEVLAR SHEARS	1278637-1	5
1	1	1	DIESET, ST	492622-1	4
1	1	1	HAND TOOL, W/DIESET (AMP SC)	492782-1	3
1	1	1	PLATE, POLISH	501197-1	2
1	1	1	PREMIUM SOFTCASE	1278540-1	1
-3	-2	-1	DESCRIPTION	PART NUMBER	ITEM

SCALE 1:2

<small>THIS DRAWING IS A CONTROLLED DOCUMENT FOR TYCO ELECTRONICS CORPORATION. IT IS SUBJECT TO CHANGE AND THE CONTROLLING ENGINEERING ORGANIZATION SHOULD BE CONTACTED FOR THE LATEST REVISION.</small>		DWN T.GREEN 05JAN00 CHK J.SABO 05JAN00 APVD J.SABO 05JAN00	<b>AMP</b> AMP Incorporated Harrisburg, PA 17105-3608
DIMENSIONS: INCHES	TOLERANCES UNLESS OTHERWISE SPECIFIED: 0 PLC ± 1 PLC ±0.1 2 PLC ±0.02 3 PLC ±0.005 4 PLC ±0.0005 ANGLES ± FINISH -	NAME <b>TERMINATION KIT, LightCrimp COMBINATION</b>	SIZE A2 CAGE CODE 00779 DRAWING NO C=503957 RESTRICTED TO -
MATERIAL -	FINISH -	WEIGHT -	SCALE 1:2 SHEET 1 OF 1 REV N
CUSTOMER DRAWING			