

## 1. INTRODUCTION

This instruction sheet provides instructions on product application and a Maintenance and Inspection Procedure for Insulation Piercing COPALUM Terminal and Splice Crimping Heads 68080 and 68093-1.

These crimping heads are used to crimp COPALUM Terminals and Splices on 20 to 10 AWG insulated solid aluminum or copper wire or stranded copper wire.

**CAUTION** Do NOT use stranded aluminum wire.



Basic instructions on the use of these heads, wire preparation, etc., are provided in Section 2. Section 3 features a terminal or splice Crimp Inspection procedure. Section 4 contains a Maintenance and Inspection Procedure which will enable you to establish and maintain a tool certification program.

Crimping heads are coated with preservative to prevent rust and corrosion. Wipe this preservative from heads, particularly from crimping surfaces.

## 2. INSTRUCTIONS

**DANGER** Avoid personal injury. Always keep fingers clear of crimping jaws when actuating air tool. Do NOT operate the tool without having head installed, and lock screw tightened.



### 2.1. Crimping Head Installation

1. Disconnect tool from air supply. Select the correct crimping head for the wire size being used. Wire range and the insulation piercing crimp symbol (▲) appear on one jaw as shown in Figure 1.
2. Remove assembly pins from mounting lugs as shown in Figure 1A.
3. Pull toggle arm forward and loosen lock screw in toggle arm. Do NOT remove lock screw. See Figure 1A.
4. Open jaws and insert toggle lever of crimping head all the way into hole in toggle arm.
5. Take up on lock screw enough to hold head in place.
6. Move head so that links align between mounting lugs of tool. See Figure 1B.

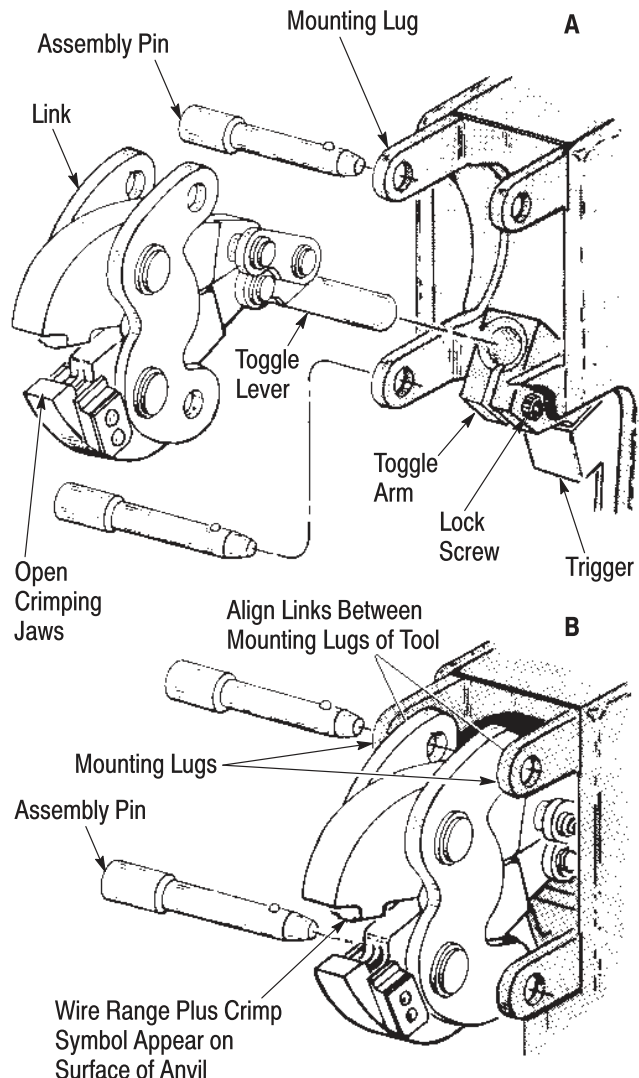

Figure 1

7. After head is aligned, lower it to provide access to lock screw on toggle arm. Tighten lock screw.
8. Move head back between mounting lugs and insert assembly pins.
9. Connect air supply 586-690 kPa [85-100 psi]. Tool is now ready to be used.

### 2.2. Crimping Head Removal

1. Disconnect tool from air supply.
2. Remove assembly pins.
3. Loosen lock screw and pull head out of toggle arm.

### 2.3. Wire Selection and Loading

Solid aluminum or copper (or a combination of both) and stranded copper conductors may be crimped in the same wire barrel under the following conditions:

**NOTE** *Conductors must always be within CMA limits of wire barrel.*

**Condition 1** – See Figure 2, Detail A.  
Maximum CMA fill for copper conductor should not exceed 40% of total CMA.  
Example: Two no. 15 solid aluminum (6,400 Cir. Mil.) plus one no. 14 stranded copper (4,000 Cir. Mil.) equals 10,400 Cir. Mil. The one no. 14 stranded copper conductor is approximately 40% of total CMA (10,400 Cir. Mil.) being crimped.

**Condition 2** – See Figure 2, Detail B.  
A maximum of 10 equal size round conductors may be crimped without removing film insulation.

**Condition 3** – See Figure 2, Detail C.  
A maximum of six equal size square conductors may be crimped without removing film insulation.

**Condition 4** – See Figure 2, Detail D.  
Four identical rectangular conductors, where one conductor thickness is equal to or greater than 1/4 of the width of one conductor, may be crimped without removing film insulation.

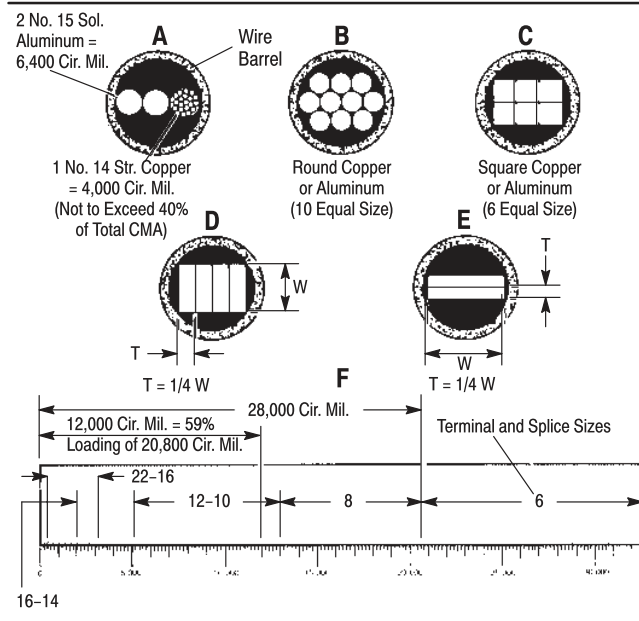

Figure 2

**Condition 5** – See Figure 2, Detail E.  
Two identical rectangular conductors, where thickness of one conductor is equal to or less than 1/4 of the width of one conductor, may be crimped without removing film insulation.

**Condition 6** – See Figure 2, Detail F.  
In some instances it may not be possible to fit a particular CMA loading into the normally recommended terminal or splice. In these cases where seven or more equal round, or a combination of solid aluminum and stranded copper conductors are used, and the total CMA is at least 50% of maximum CMA of the next larger size terminal or splice, the larger size may be used.

Example: Three no 14 solid conductors equal about 12,000 Cir. Mils. This falls within the CMA range of a 12-10 terminal or splice accepting a maximum CMA of 13, 100 Cir. Mils. However, it may not be possible to insert all three conductors into the recommended terminal or splice. It is possible to insert all three conductors into a no. eight size terminal or splice accepting a CMA range of 13,100-20,800 Cir. Mils. amounts to 59% loading of the maximum CMA for no. 8 size terminals or splices. Therefore, no. 8 size terminals or splices may be used.

**Condition 7** – When using a variety of solid conductor sizes, none of the conductors should vary more than one (1) wire gage. (Ideally not more than 1/2 wire gage.)

### 2.4. Wire Preparation

**CAUTION** *Do NOT use stranded aluminum wire.*

1. Select the proper terminal, or splice wire range and crimping head combination for the wire being used. See Figure 3.
2. Determine correct terminal or splice wire loading by referring to Paragraph 2.3, and CMA range listed in Figure 3.
3. Strip stranded copper wire to dimension indicated in Figure 3.

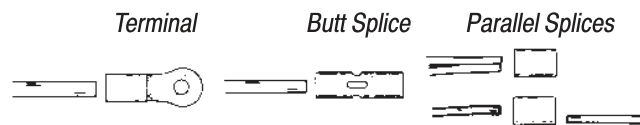

HEAD	WIRE RANGE	CMA RANGE	WIRE STRIP LENGTH (Stranded Copper Wire Only) (mm [in.])	
			Max.	Min.
68093-1	16-14	2,050-5,180	7.14 [.281]	8.74 [.344]
68080	12-10	5,180-13,100	8.74 [.344]	10.31 [.406]

Figure 3

**NOTE**  
 It is not necessary to strip film insulated aluminum or copper wires.

**2.5. Crimping Procedure**

**DANGER**  
 Avoid personal injury. When operating air tool, exercise caution while holding terminals, splices, or wire near crimping area.

**A. Terminals**

1. Ensure that the wire range stamped on the terminal corresponds with the wire range stamped on the crimping head link.
2. Position terminal wire barrel between locators of lower jaw as shown in Figure 4A.
3. Insert wire into terminal wire barrel until end of wire is flush with or extended slightly beyond end of wire barrel. Hold terminal in place, squeeze trigger to complete crimp.
4. Release trigger and remove crimped terminal.
5. Refer to Section 3 and Figure 5 for crimp inspection.

**B. Butt Splices**

**NOTE**  
 Ensure that wire range stamped on splice corresponds with the wire range stamped on the crimping head link.

1. Position butt splice in lower jaw so that end of splice butts against locator and window in splice faces upper jaw. See Figure 4B.
2. Insert wire into splice until it bottoms against splice wire stop. Hold splice in place, squeeze trigger to complete crimp.
3. Release trigger and remove crimped splice.
4. To crimp other half of butt splice, remove it and reposition uncrimped half in crimping jaws and follow same procedure used to crimp first half of splice. If splice cannot be turned, turn tool around.

**NOTE**  
 Butt splices may be slightly bent when crimped as instructed in Step 2.5.B.4. If this bending is objectionable, use the following crimping procedure.

5. To crimp other half of butt splice, remove and rotate splice 180° end over end. Reposition uncrimped half in lower jaw as described in Step 2.5.B.1. If splice cannot be rotated, rotate tool, insert wire, and then crimp the splice.

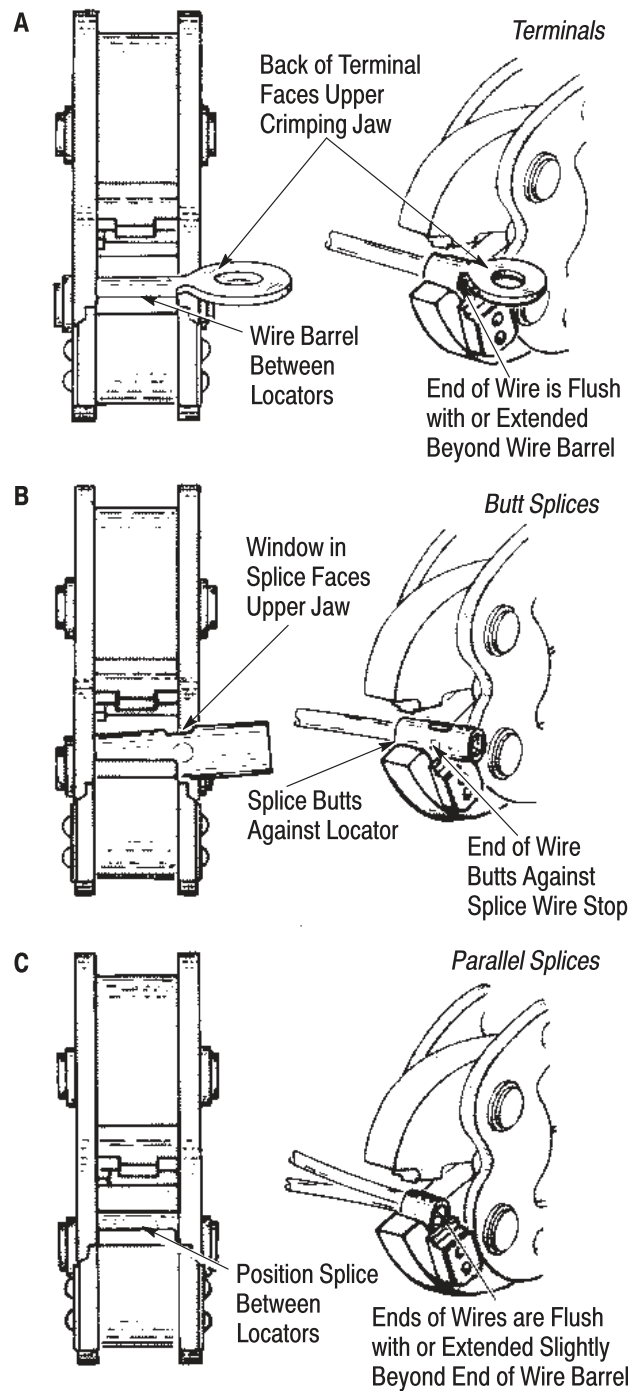



Figure 4

6. Refer to Section 3 and Figure 5 for crimp inspection.

**C. Parallel Splices**

**NOTE**  
 Ensure that wire range stamped on splice corresponds with the wire range stamped on the crimping head link.

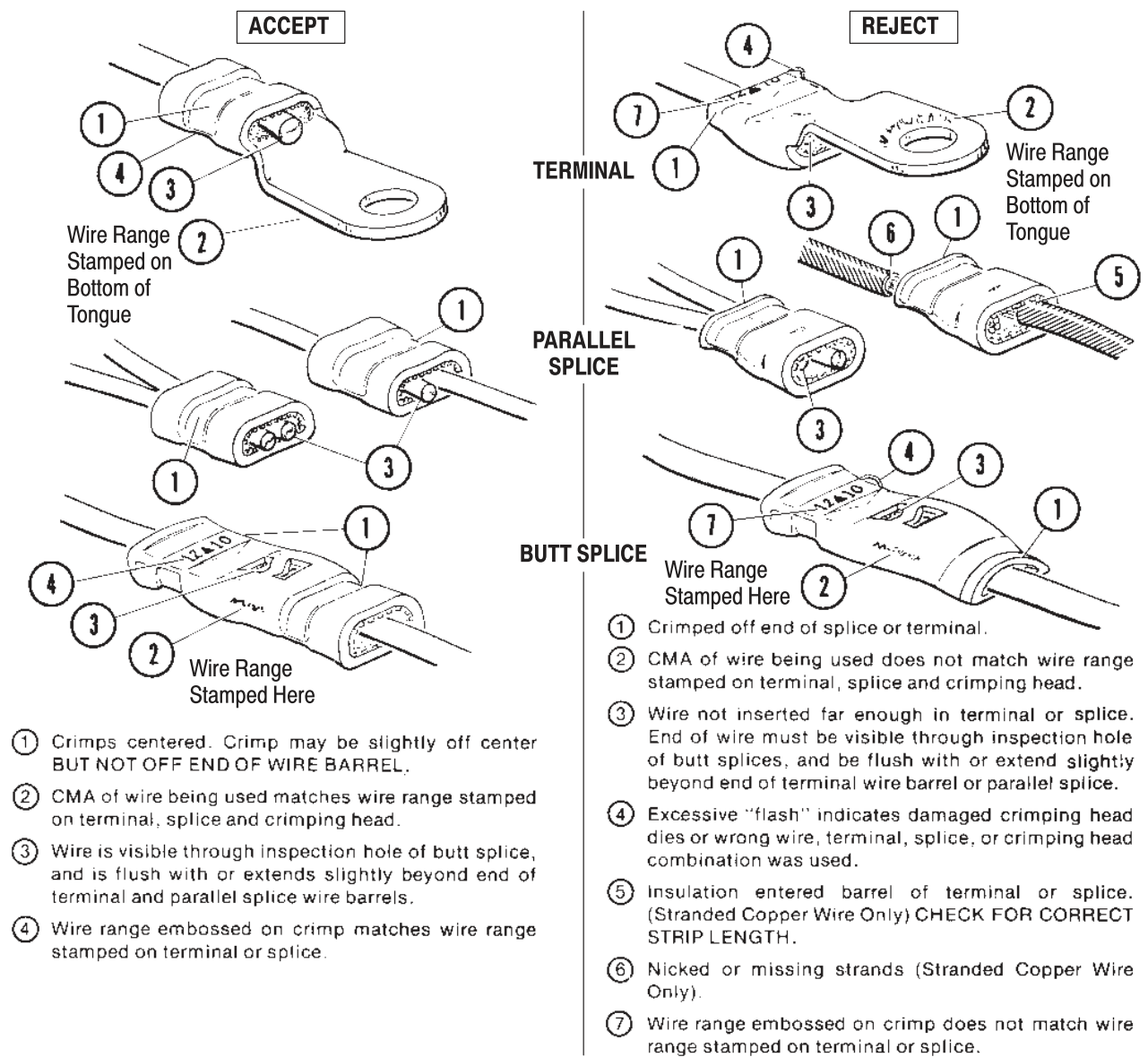

Figure 5

1. Position splice between locators as shown in Figure 4C.
2. Insert wires into splice until ends of wires are flush with or extended slightly beyond end of wire barrel. Hold splice in place, squeeze trigger to complete the crimp.
3. Release trigger and remove crimped splice.
4. Refer to Section 3 and Figure 5 for crimp inspection.

### 3. CRIMP INSPECTION

Inspect crimped terminals and splices by checking the features described in Figure 5. Use only the terminals and splices that meet the conditions shown in the "ACCEPT" column. "REJECT" terminals and splices can be avoided through careful use of instructions in Section 2, and by performing regular crimping head maintenance as instructed in Section 4.

### 4. MAINTENANCE/INSPECTION PROCEDURE

Tyco Electronics recommends that a maintenance/inspection program be performed periodically to ensure dependable and uniform terminations. Crimping heads should be inspected at least once a month. Frequency of inspection is dependent upon:

**NOTE**



*If COPALUM terminal or splice sticks in die after crimping, apply a rocking action to remove from die.*

- The care, amount of use, and handling of the head.
- The type and size of the products crimped.
- The degree of operator skill.
- The presence of abnormal amounts of dust and dirt.
- Your own established standards.

All crimping heads are thoroughly inspected before packaging. Since there is a possibility of damage in shipment, new heads should be inspected in accordance with the following instructions when received in your plant.

#### 4.1. Cleaning



*Do NOT allow deposits of dirt, grease, and foreign matter to accumulate on the jaw bottoming surfaces and die closure surfaces. These deposits may cause excessive wear, thereby affecting the quality of the crimp.*

The crimping head should be immersed in a reliable commercial de-greasing compound to remove accumulated dirt, grease, and foreign matter. Remove remaining de-greasing compound with a lint-free cloth. When de-greasing compounds are not available, head may be wiped clean with a lint-free cloth. Re-lubricate head as instructed in Paragraph 4.3, before placing it back in service.

#### 4.2. Visual Inspection

**A.** Visually inspect the crimping head for missing pins or retaining rings. If parts are missing or defective, refer to Figure 10 for customer replaceable parts.

**B.** Inspect the die closure surfaces of the head for broken, pitted, or chipped conditions. Although dies may gage within permissible limits, worn or damaged die closure surfaces are objectionable and can affect the quality of the crimp. Examples of possible damaged die closure surfaces are shown in Figure 6.

#### 4.3. Lubrication

Lubricate all pins, pivot points, and bearing surfaces with a good grade S.A.E. no. 20 motor oil as follows:

Heads used in daily production – Lubricate daily  
 Heads used daily (occasional) – Lubricate weekly  
 Heads used weekly – Lubricate monthly

Wipe excess oil from head, particularly from crimping area. Oil transferred from the crimping area onto certain terminations may affect the electrical characteristics of an application.

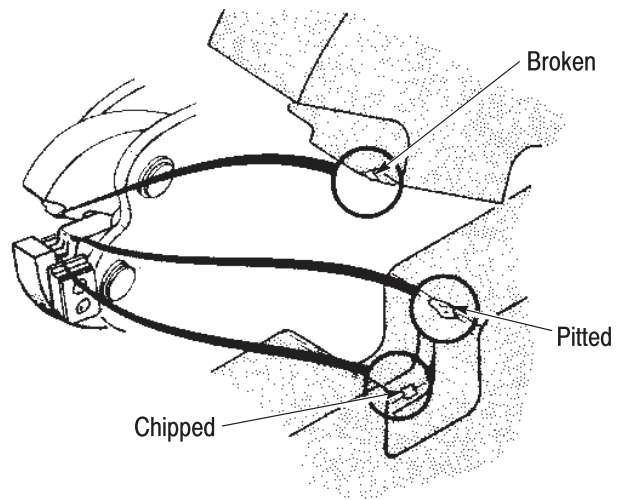

Figure 6

#### 4.4. Die Closure Inspection

Every crimping head is inspected for proper die closure before packaging. An inspection should be performed periodically to check the die closure for excessive wear. The die closure inspection is accomplished using GO/NO-GO plug gages. Tyco Electronics neither manufactures nor sells plug gages. A suggested plug gage design and the GO/NO-GO dimensions of the plug gage members are listed in Figures 7 and 8. The following procedure is recommended for inspecting the die closures.

1. Clean oil or dirt from die closure surfaces, bottoming surfaces, and plug gage members.
2. Select the proper GO gage. Position gage member in lower jaw inner crimp closure so that locator is in notch of gage member. See Figure 9, Detail A.
3. Close the crimping jaws until they are bottomed but not under pressure.
4. To meet the GO gage conditions, the plug gage must be able to be rotated freely in either direction as shown in Figure 9, Detail A.
5. Select the proper NO-GO gage. Position gage member in lower jaw inner crimp closure so that locator is in notch of gage member. See Figure 9, Detail B.
6. Close the crimping jaws so that inner crimp surfaces are seated on the NO-GO gage member.
7. To meet the NO-GO gage conditions, jaw bottoming surfaces will NOT bottom, and NO-GO gage member will be held stationary (will not rotate) by the dies. See Figure 9, Detail B.
8. Inspect the right and left outer crimp closures in the same manner as steps 4.4.2 thru 4.4.7. See Figure 9, Details C and D.

9. If both the inner crimp and the outer crimp closures meet the GO/NO-GO gage conditions, the die closures may be considered dimensionally

correct. If you find that the die closures do not conform with the GO/NO-GO gage conditions, contact your local Tyco Electronics Representative.

**SUGGESTED PLUG GAGE DESIGN - INNER CRIMP**

**INNER CRIMP DIE CLOSURE CONFIGURATION**

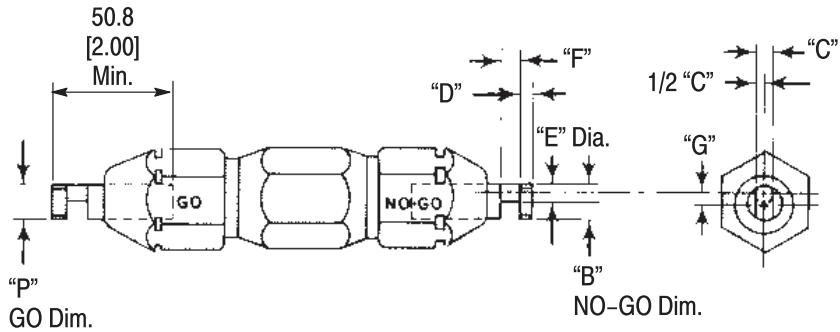
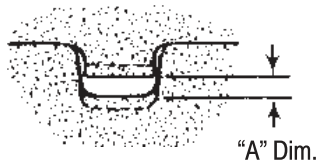

HEAD	DIE CLOSURE DIM's "A"		GAGE MEMBER• DIM's "B" DIA		"C"	"D"	"E" DIA	"F"	"G"
	GO‡	NO-GO	GO	NO-GO					
68080	2.362 [.0930]	2.616 [.1030]	2.362-2.370 [.0930-.0933]	2.614-2.616 [.1029-.1030]	1.02 [.040]	5.84 [.230]	1.02 [.040]	7.87 [.310]	0.69 [.027]
68093-1	1.550 [.0610]	1.803 [.0710]	1.549-1.557 [.0610-.0613]	1.801-1.803 [.0709-.0710]	0.76 [.030]	4.32 [.170]	0.76 [.030]	8.64 [.340]	0.38 [.015]

Figure 7

**SUGGESTED PLUG GAGE DESIGN - OUTER CRIMP**

**OUTER CRIMP DIE CLOSURE CONFIGURATION**

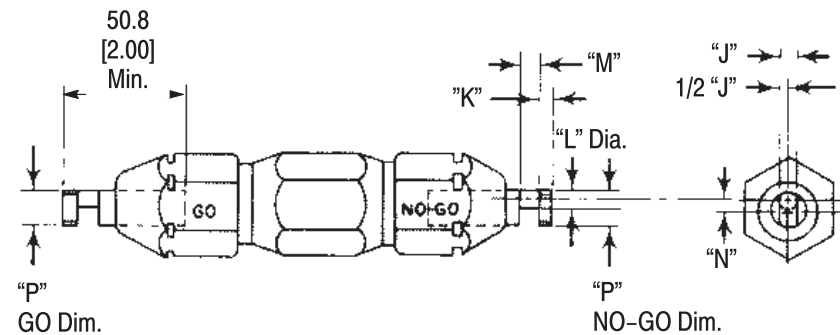
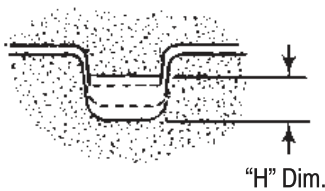

HEAD	DIE CLOSURE DIM's "H"		GAGE MEMBER• DIM's "P" DIA		"J"	"K"	"L" DIA	"M"	"N"
	GO‡	NO-GO	GO	NO-GO					
68080	3.429 [.1350]	3.785 [.1490]	3.429-3.437 [.1350-.1353]	3.782-3.785 [.1489-.1490]	1.78 [.070]	2.54 [.100]	1.78 [.070]	7.87 [.310]	0.89 [.035]
68093-1	2.235 [.0880]	2.591 [.1020]	2.235-2.243 [.0880-.0883]	2.588-2.591 [.1019-.1020]	1.02 [.040]	1.75 [.069]	1.02 [.040]	7.87 [.310]	0.58 [.023]

Figure 8

• Material – Tool Steel ‡ "GO" dimensions apply when jaws are bottomed but not under pressure.

**INSPECTION OF INNER CRIMP CLOSURE**

**INSPECTION OF OUTER CRIMP CLOSURES**

**DETAIL A  
GO GAGE**

**DETAIL C  
GO GAGE**

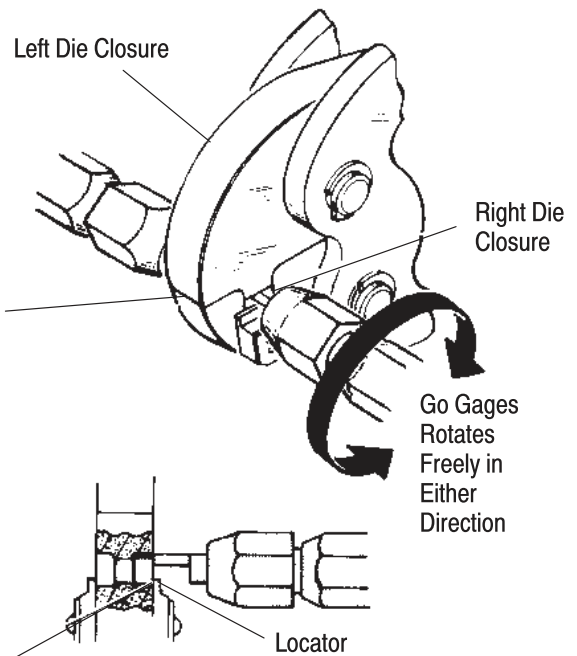
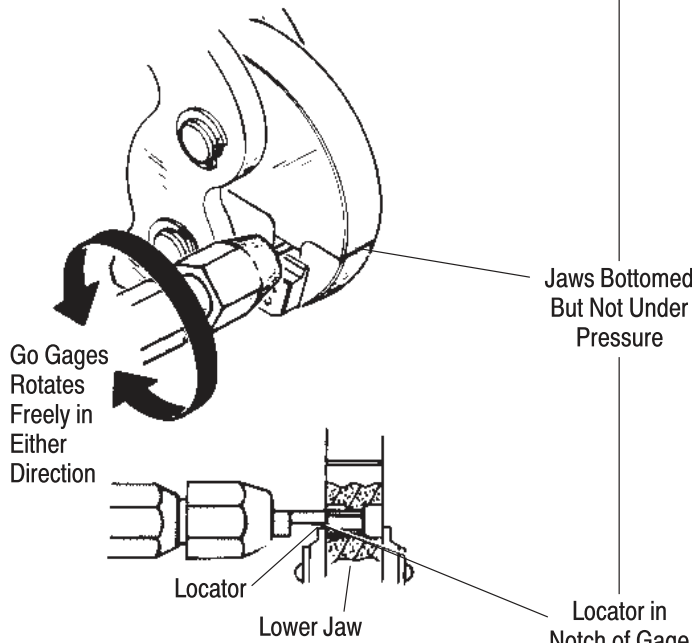

**DETAIL B  
NO-GO GAGE**

**DETAIL D  
NO-GO GAGE**

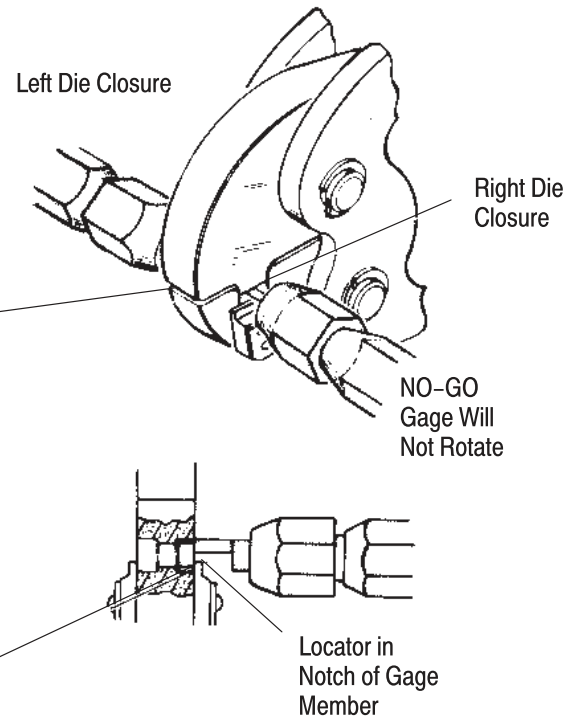
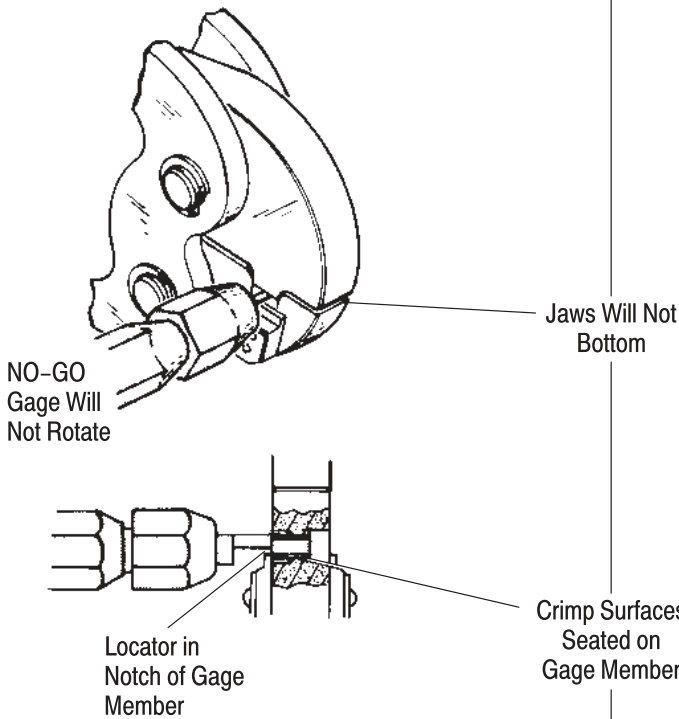

Figure 9

**4.5. Replacement Parts**

It may be advantageous to stock certain replaceable parts to prevent loss of production time. Figure 10 lists the customer replaceable parts that can be purchased from Tyco Electronics. Order replacements through your Tyco Electronics Representative, or call 1-800-526-5142, or send a facsimile of your purchase order to 717-986-7605, or write to:

CUSTOMER SERVICE (038-035)  
 TYCO ELECTRONICS CORPORATION  
 P.O. BOX 3608  
 HARRISBURG, PA 17105-3608

**5. REVISION SUMMARY**

- Updated document to corporate requirements
- Deleted obsolete part number 68134 and related information in all instances
- New format and logo

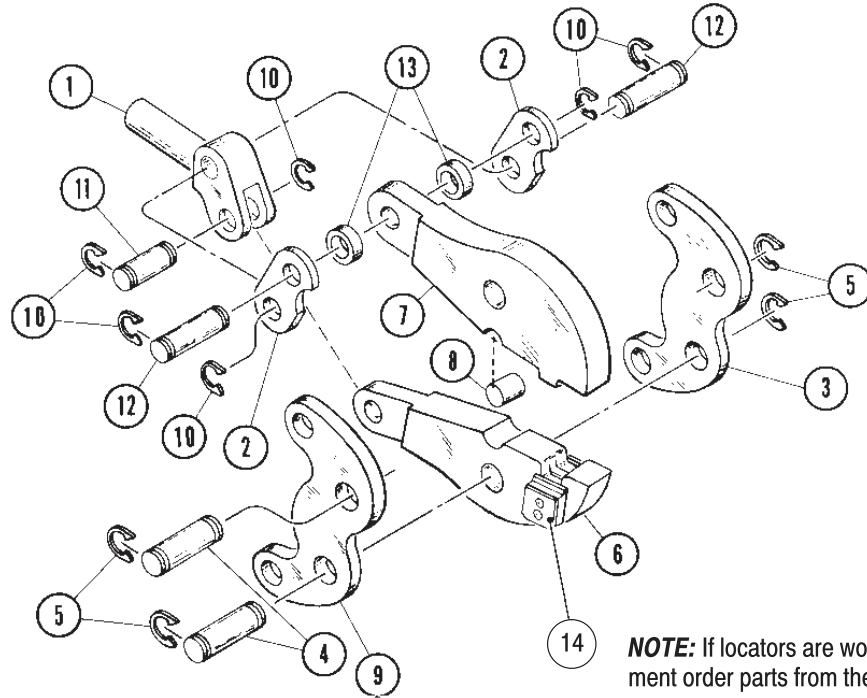

**NOTE:** If locators are worn and need replacement order parts from the table below.

ITEM NO.	DESCRIPTION	QTY PER HEAD	TOOL NUMBERS	
			68080	68093-1
1	LEVER, Toggle	1	38379	38379
2	LINK, Toggle	2	38380	38380
3	LINK	1	4-306322-9	5-306322-1
4	PIN, Retaining	2	38384	39384
5	RING, Retaining	4	21045-8	21045-8
6	LOWER JAW, with Locators	1	307828-1	307828-2
7	UPPER JAW	1	307796-1	307794-2
8	PIN, Pivot	1	38385	38385
9	LINK	1	306322-4	306322-4
10	RING, Retaining	6	21045-6	21045-6
11	PIN, Retaining	1	300448	300448
12	PIN, Retaining	2	2-23620-9	2-23620-9
13	SPACER	2	38716	38716
14	RIVET	2	1-59573-8	1-59573-9
	PLATE, Locator	2	308173-1	308173-1
	LOCATOR	2	308172-1	308172-1

Figure 10