

CARRIER VIEW

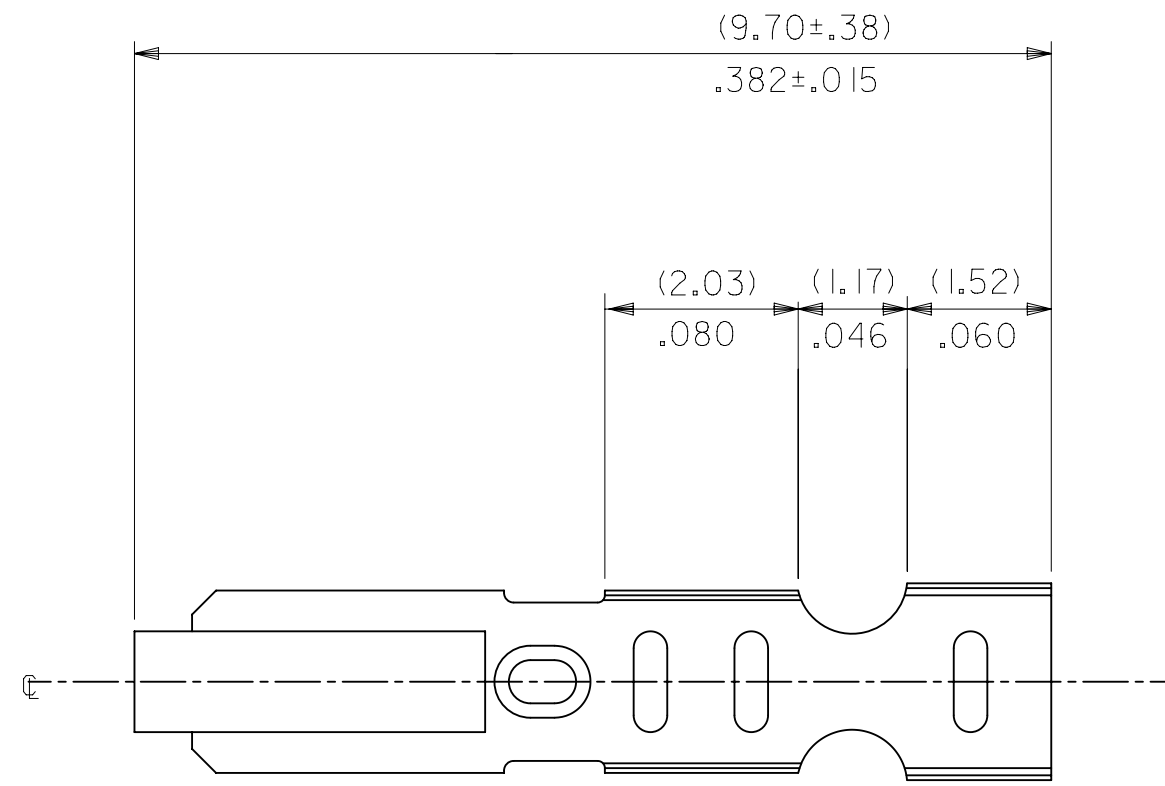
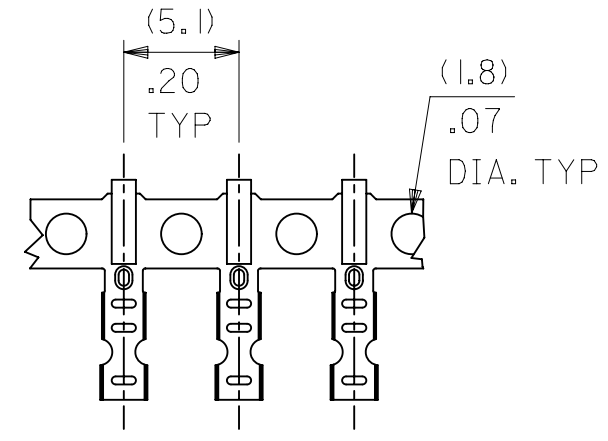

NOTES:

- MATERIAL:
(0.20)/.008 THICK BRASS
- FINISH:
122 - OVERALL TIN: (0.00381)/.000150 MIN. TIN OVER
(0.00076)/.000030 MIN NICKEL
154 - OVERALL TIN: (0.00254)/.000100 MIN. TIN OVER
(0.00127)/.000050 MIN NICKEL
P909 - OVERALL HOT TIN DIP: (0.00254)/.000100 MIN.
550 - SELECT GOLD: (0.00038)/.000015 MIN.
OVERALL GOLD FLASH: (0.00005)/.000002 MIN.
OVERALL NICKEL UNDERPLATE: (0.00076)/.000030 MIN.
555- SELECT GOLD (0.00038)/.000015 MIN.
OVERALL NICKEL UNDERPLATE: (0.00076)/.000030
558 - SELECT GOLD: (0.00076)/.000030 MIN.
OVERALL GOLD FLASH: (0.00005)/.000002 MIN.
OVERALL NICKEL UNDERPLATE: (0.00127)/.000050 MIN.
- PRODUCT SPEC: PS-10-07
- PACKAGING SPECIFICATION: LOOSE TERMINALS: PER PK-2759-001
CHAIN FORM TERMINALS: PER PK-2759-002
- CRIMP IS FOR 22-30 GA WIRE WITH (1.57)/.062 DIA INSULATION MAX.
- INSERTION FORCE OF TERMINAL INTO (2.54)/.100 CENTERLINE CONNECTOR IS 2.5 LBS. MAX
- TERMINAL RETENTION IN HOUSING IS 26.7N / 6LBS MIN. WHEN PULLED AT THE RATE OF (25.4MM) / 1 INCH PER MINUTE.
- DIMENSIONS GIVEN ACROSS CENTERLINES ARE SYMMETRICAL ABOUT THOSE CENTERLINES WITHIN HALF THE TOTAL TOLERANCE.
- THIS PART CONFORMS TO CLASS B REQUIREMENTS OF COSMETIC SPECIFICATION PS-45499-002.

SELECT GOLD LOCATION

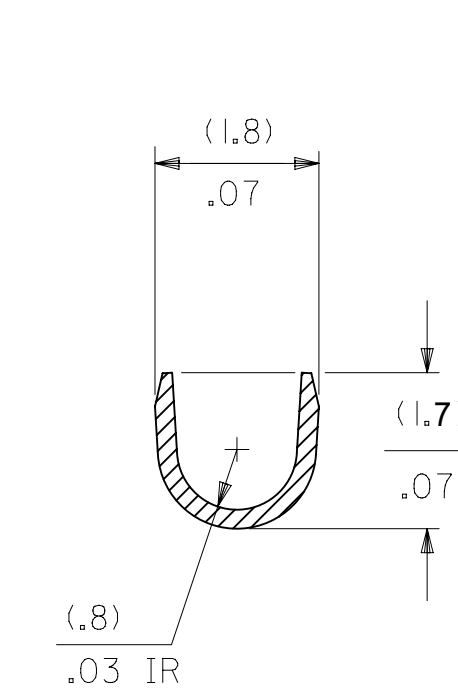
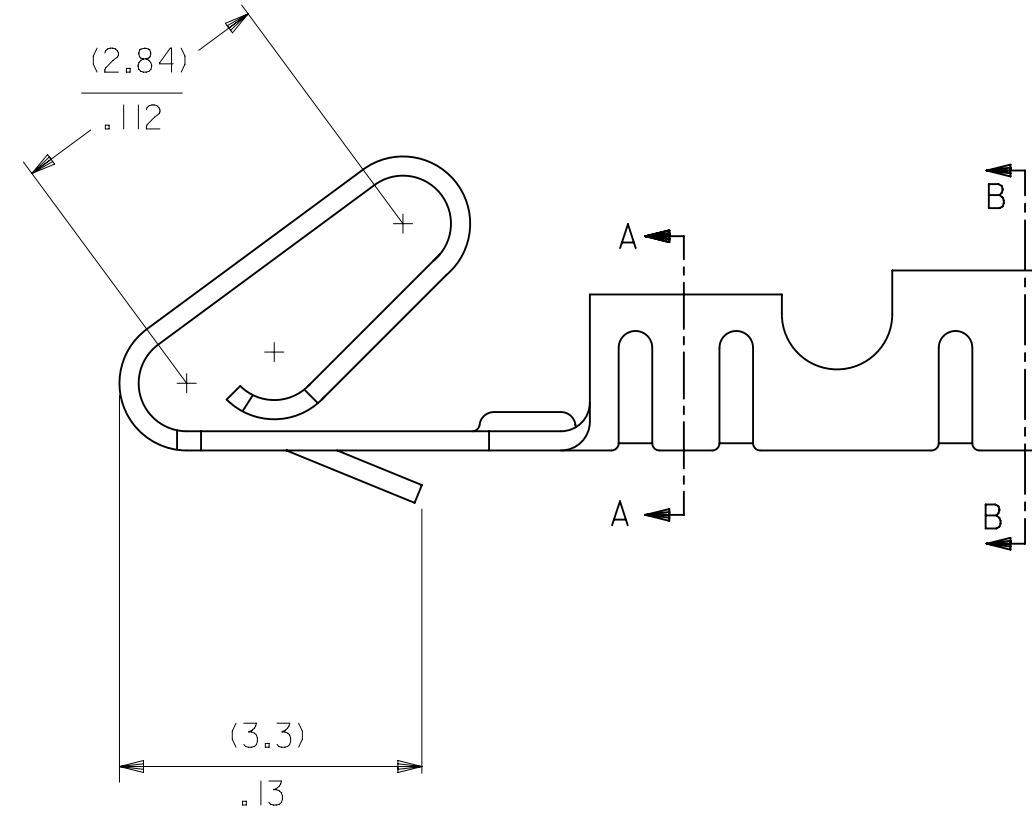
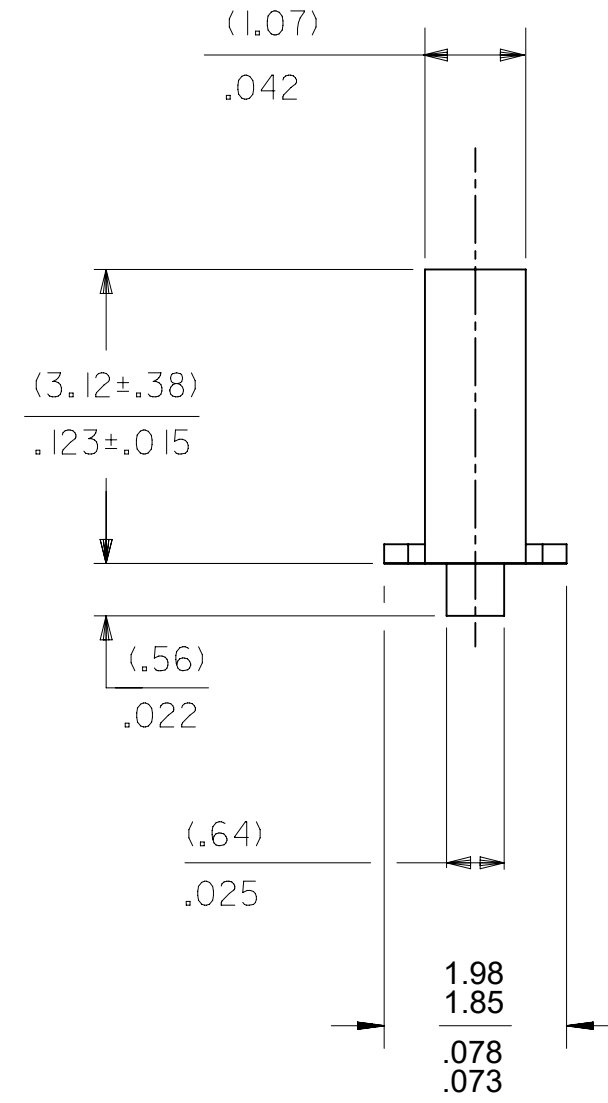
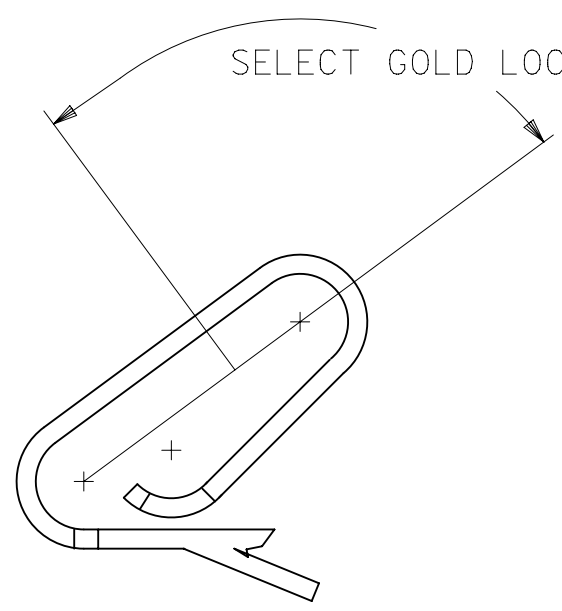

SECTION A-A
BACKGROUND OMITTED

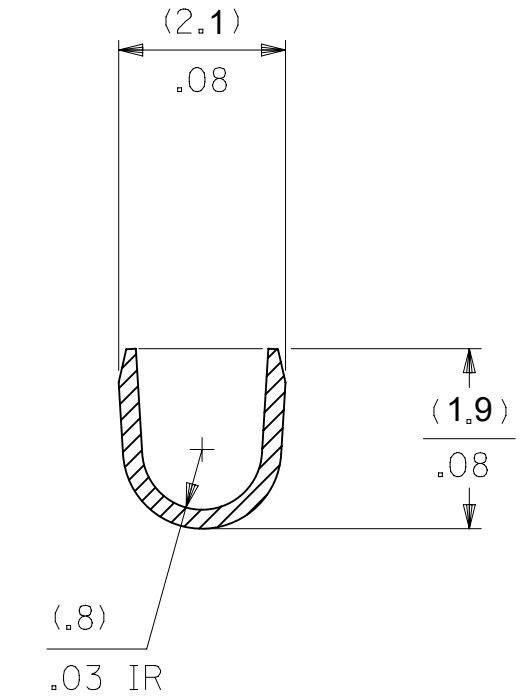

SECTION B-B
BACKGROUND OMITTED

CRIMP DETAIL

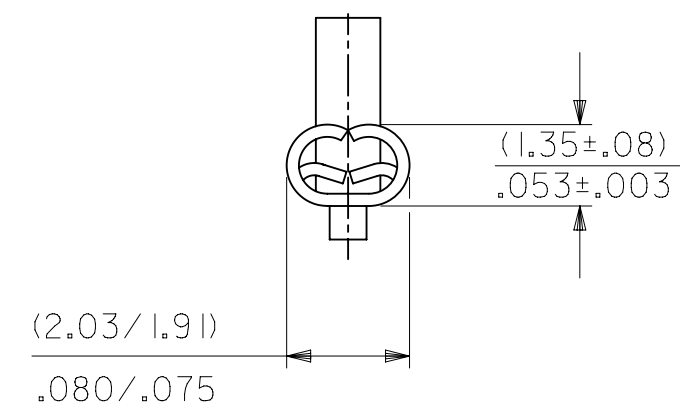

CRIMPED TERMINAL 2759-(P909)C IS USED WITHOUT WIRE AND IS INSERTED INTO HOUSING TO PROVIDE TENSION WHEN ASSEMBLED TO HEADERS DURING SHIPMENT.

2759-(***)*

FORM

L=LOOSE

C=LOOSE CRIMPED

A=CHAIN, PER WINDING DETAIL "A"

B=CHAIN, PER WINDING DETAIL "B"

PLATING

SEE NOTE 2

THIS DRAWING CONTAINS INFORMATION THAT IS PROPRIETARY TO MOLEX ELECTRONIC TECHNOLOGIES, LLC AND SHOULD NOT BE USED WITHOUT WRITTEN PERMISSION

DIMENSION UNITS: MM/IN
SCALE: 1:1

CURRENT REV DESC: OBSOLETE PART NUMBER AS PER PCN#509451

GENERAL TOLERANCES (UNLESS SPECIFIED)

	MM	INCH
4 PLACES ±	±	±
3 PLACES ±	± 0.01	± 0.01
2 PLACES ±	0.25 ± 0.014	± 0.014
1 PLACE ±	0.36 ±	±
0 PLACES ±	±	±
ANGULAR TOL	± 0.5 °	± 0.5 °

EC NO: 686785
DRWN: SUGEEB 2021/08/31
CHK'D: GGA 2022/02/28
APPR: GGA 2022/02/28
INITIAL REVISION:
DRWN: SAMIEC 1987/07/28
APPR: FSMITH 2012/03/20

molex

CRIMP TERMINAL
22-30 GA WIRE

PRODUCT CUSTOMER DRAWING

DOCUMENT NUMBER	DOC TYPE	DOC PART	REVISION
SD-2759	PSD	001	AW3

DRAFT WHERE APPLICABLE MUST REMAIN WITHIN DIMENSIONS	THIRD ANGLE PROJECTION	DRAWING	SERIES	MATERIAL NUMBER	CUSTOMER	SHEET NUMBER
		D-SIZE	2759	SEE TABLE	GENERAL MARKET	1 OF 2

2759-(***)*		
	PART NO.	ENG. NO.
	08-55-0101	2759-(555)B
	08-55-0102	2759-(555)L
	08-55-0126	2759-(555)A
	08-56-0109	2759-(550)B
	08-56-0110	2759-(550)L
	08-50-0113	2759-(P909)B
	08-51-0108	2759-(122)B
		2759-(122)L
	08-50-0274	2759-(P909)B
	08-55-0130	2759-(558)B
	08-55-0131	2759-(558)L
	08-50-0160	2759-(154)L
	08-50-0159	2759-(154)B

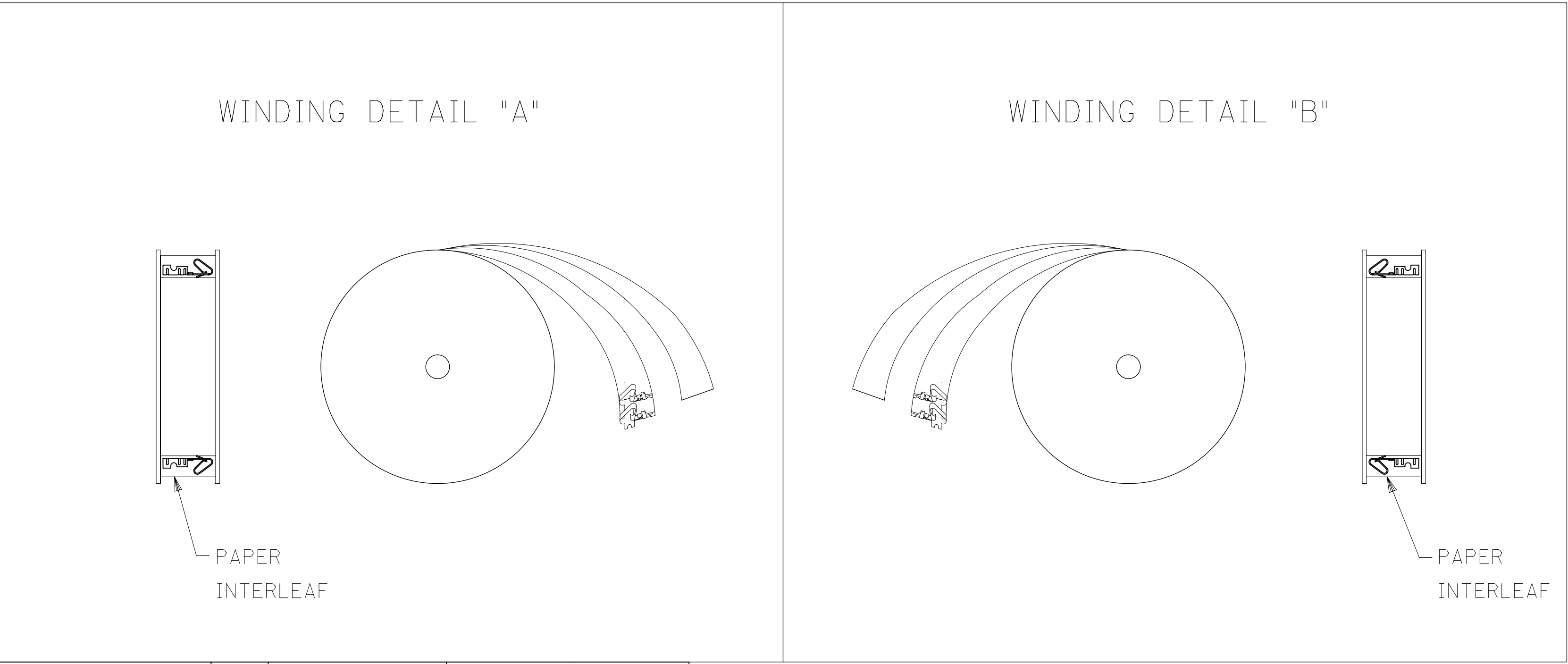

THIS DRAWING CONTAINS INFORMATION THAT IS PROPRIETARY TO MOLEX ELECTRONIC TECHNOLOGIES, LLC AND SHOULD NOT BE USED WITHOUT WRITTEN PERMISSION AS PER PCN#509451

DIMENSION UNITS	SCALE	CURRENT REV DESC: OBSOLETE PART NUMBER AS PER PCN#509451	
MM/IN	1:1		
GENERAL TOLERANCES (UNLESS SPECIFIED)		EC NO: 686785 DRWN: SUGEEB 2021/08/31 CHK'D: GGA 2022/02/28 APPR: GGA 2022/02/28 INITIAL REVISION: DRWN: SAMIEC 1987/07/28 APPR: FSMITH 2012/03/20	
	MM		
	INCH		
4 PLACES	±		
3 PLACES	±		± 0.01
2 PLACES	±		± 0.25 ± 0.014
1 PLACE	±	± 0.36 ±	
0 PLACES	±	±	
ANGULAR TOL	±	± 0.5 °	
DRAFT WHERE APPLICABLE MUST REMAIN WITHIN DIMENSIONS		THIRD ANGLE PROJECTION 	

<h1>molex</h1>			
CRIMP TERMINAL 22-30 GA WIRE			
PRODUCT CUSTOMER DRAWING			
DOCUMENT NUMBER	DOC TYPE	DOC PART	REVISION
SD-2759	PSD	001	AW3
MATERIAL NUMBER	CUSTOMER	SHEET NUMBER	
SEE TABLE	GENERAL MARKET	2 OF 2	