

#### Description

The MK2308-1H is a low phase noise, high-speed PLL based, 8-output, low skew zero delay buffer. Based on IDT's proprietary low jitter Phase Locked Loop (PLL) techniques, the device provides eight low skew outputs at speeds up to 133 MHz at 3.3 V. The outputs can be generated from the PLL (for zero delay), or directly from the input (for testing), and can be set to tri-state mode or to stop at a low level. For normal operation as a zero delay buffer, any output clock is tied to the FBIN pin.

IDT manufactures a large variety of clock generators and buffers.

#### Features

- Clock outputs from 10 to 133 MHz
- Zero input-output delay
- Eight low skew (<200 ps) outputs
- Device-to-device skew <700 ps
- Full CMOS outputs with 25 mA output drive capability at TTL levels
- 5 V tolerant FBIN and CLKIN pins
- Tri-state mode for board-level testing
- Advanced, low-power, sub-micron CMOS process
- Operating voltage of 3.3 V
- Industrial temperature range available
- Packaged in 16-pin SOIC and TSSOP packages
- Pb (lead) free package
- Industrial and commercial temp operation

#### Block Diagram

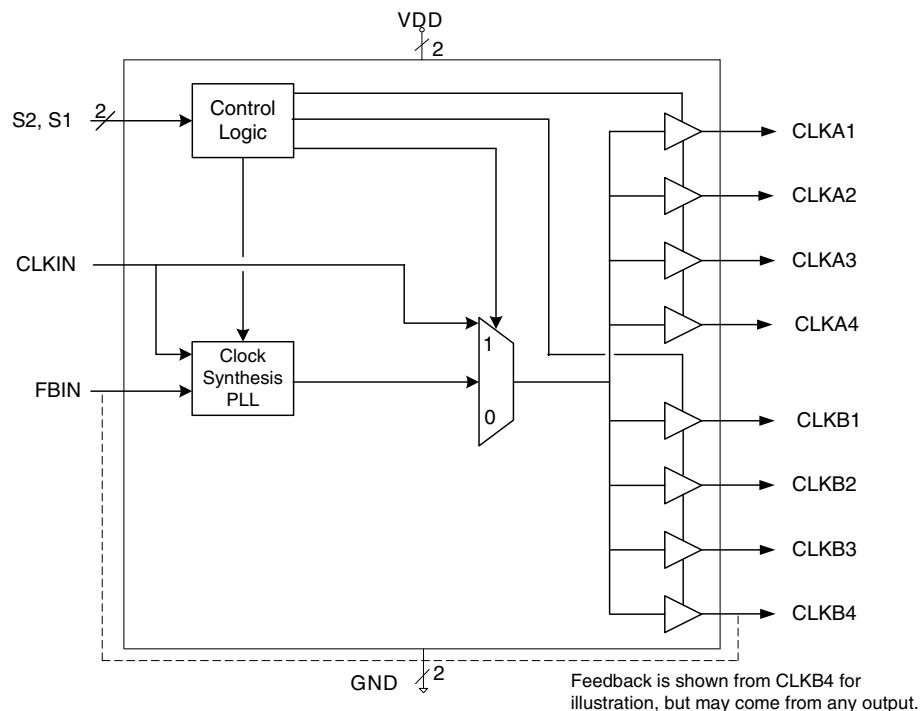

## Pin Assignment

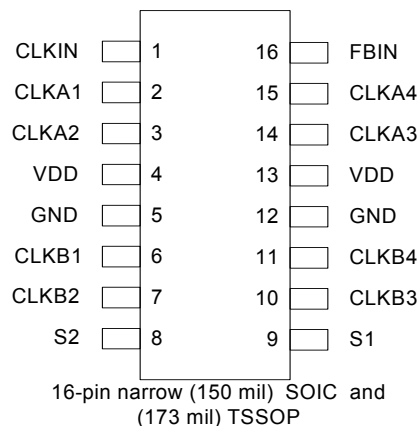

## Output Clock Mode Select Table

S2	S1	CLKA1:A4	CLKB1:B4	A & B Source	PLL Status
0	0	Tri-state (note 1)	Tri-state (note 1)	PLL	OFF
0	1	Running	Tri-state (note 1)	PLL	ON
1	0	Running	Running	CLKIN (note 2)	OFF
1	1	Running	Running	PLL	ON

Note 1. Outputs are in high impedance state

Note 2. Buffer mode only; not zero delay between input and output

## Pin Descriptions

Pin Number	Pin Name	Pin Type	Pin Description
1	CLKIN	Input	Clock input (5 V tolerant).
2 - 3	CLKA1:A4	Output	Clock outputs A1:A4. See table above.
4	VDD	Power	Power supply. Connect to 3.3 V.
5	GND	Power	Connect to ground.
6 - 7	CLKB1:B4	Output	Clock outputs B1:B4. See table above.
8	S2	Input	Select input 2. See table above. Internal pull-up.
9	S1	Input	Select input 1. See table above. Internal pull-up.
10 - 11	CLKB1:B4	Output	Clock outputs B1:B4. See table above.
12	GND	Power	Connect to ground.
13	VDD	Power	Power supply. Connect to 3.3 V.
14 - 15	CLKA1:A4	Output	Clock outputs A1:A4. See table above.
16	FBIN	Input	Feedback input. Connect to any output under normal operation (5 V tolerant).

## External Components

The MK2308-1H requires a minimum number of external components for proper operation. Decoupling capacitors of 0.01 mF should be connected between VDD and GND on pins 4 and 5, and VDD and GND on pins 13 and 12, as close to the device as possible. A series termination resistor of 33Ω may be used to each clock output pin to reduce reflections.

## Absolute Maximum Ratings

Stresses above the ratings listed below can cause permanent damage to the MK2308-1H. These ratings, which are standard values for IDT commercially rated parts, are stress ratings only. Functional operation of the device at these or any other conditions above those indicated in the operational sections of the specifications is not implied. Exposure to absolute maximum rating conditions for extended periods can affect product reliability. Electrical parameters are guaranteed only over the recommended operating temperature range.

Item	Rating
Supply Voltage, VDD	7 V
All Inputs and Outputs	-0.5 V to VDD+0.5 V
CLKIN and FBIN inputs	-0.5 V to 5.5 V
Electrostatic Discharge	2000 V
Ambient Operating Temperature	0 to +70° C
Industrial Temperature	-40 to +85° C
Storage Temperature	-65 to +150° C
Junction Temperature	150° C
Soldering Temperature	260° C

## Recommended Operation Conditions

Parameter	Min.	Typ.	Max.	Units
Ambient Operating Temperature	-40		+85	°C
Power Supply Voltage (measured in respect to GND)	+3.0		+3.6	V

## DC Electrical Characteristics

VDD=3.3 V ±10%, Ambient temperature -40 to +85° C (Industrial), 0 to 70° C (Commercial)

Parameter	Symbol	Conditions	Min.	Typ.	Max.	Units
Operating Voltage	VDD		3.0		3.6	V
Input High Voltage	V <sub>IH</sub>		2			V
Input Low Voltage	V <sub>IL</sub>				0.8	V
Input Low Current	I <sub>IL</sub>	V <sub>IN</sub> = 0V			50	μA
Input High Current	I <sub>IH</sub>	V <sub>IN</sub> = VDD			100	μA
Output High Voltage	V <sub>OH</sub>	I <sub>OH</sub> = -12 mA	2.4			V
Output Low Voltage	V <sub>OL</sub>	I <sub>OL</sub> = 12 mA			0.4	V

Parameter	Symbol	Conditions	Min.	Typ.	Max.	Units
Output High Voltage, CMOS level	$V_{OH}$	$I_{OH} = -4 \text{ mA}$	$V_{DD}-0.4$			V
Operating Supply Current	$I_{DD}$	No Load, $S2 = 1, S1 = 1$ , Note 1			70	mA
Power Down Supply Current	$I_{DDPD}$	$CLKIN = 0, S2 = 0, S1 = 1$		12		$\mu\text{A}$
		$CLKIN = 0$ , Note 2		12		$\mu\text{A}$
Short Circuit Current	$I_{OS}$	Each output		$\pm 70$		mA
Input Capacitance	$C_{IN}$	$S2, S1, FBIN$		5		pF

## AC Electrical Characteristics

VDD = 3.3 V  $\pm 10\%$ , Ambient Temperature -40 to +85°C (Industrial), 0 to 70°C (Commercial)

Parameter	Symbol	Conditions	Min.	Typ.	Max.	Units
Input Clock Frequency	$f_{IN}$	See table on page 2	10		133	MHz
Output Clock Frequency		See table on page 2	10		133	MHz
Output Rise Time	$t_{OR}$	0.8 to 2.0V, $CL=30\text{pF}$			1.5	ns
Output Fall Time	$t_{OF}$	2.0 to 0.8V, $CL=30\text{pF}$			1.25	ns
Output Clock Duty Cycle	$t_{DC}$	measured at $V_{DD}/2$	45	50	55	%
Device to Device Skew		rising edges at $V_{DD}/2$			700	ps
Output to Output Skew		rising edges at $V_{DD}/2$			200	ps
Input to Output Skew		rising edges at $V_{DD}/2$ , $FBIN$ to $CLKA4$ , $S1 = 1, S0 = 1$ , Note 1			$\pm 250$	ps
Maximum Absolute Jitter		$CL=15 \text{ pF}$ , measured at 66.67M		130		ps
Cycle to Cycle Jitter		$CL=30 \text{ pF}$ , measured at 66.67M			200	ps
		$CL=15 \text{ pF}$ , measured at 66.67M			200	ps
		$CL=15 \text{ pF}$ , measured at 133.33M			100	ps
PLL Lock Time		Note 3			1.0	ms

Note 1: With  $CLKIN = 100 \text{ MHz}$ ,  $FBIN$  to  $CLKA4$ , all outputs at 100 MHz

Note 2: When there is no clock signal present at  $CLKIN$ , the MK2308-1H will enter power down mode. The PLL is stopped and the outputs are tri-state.

Note 3: With  $V_{DD}$  at a steady rate and valid clocks at  $CLKIN$  and  $FBIN$

## Thermal Characteristics 16TSSOP

Parameter	Symbol	Conditions	Min.	Typ.	Max.	Units
Thermal Resistance Junction to Ambient	$\theta_{JA}$	Still air		78		$^{\circ}\text{C/W}$
	$\theta_{JA}$	1 m/s air flow		70		$^{\circ}\text{C/W}$
	$\theta_{JA}$	3 m/s air flow		68		$^{\circ}\text{C/W}$
Thermal Resistance Junction to Case	$\theta_{JC}$			37		$^{\circ}\text{C/W}$

### Thermal Characteristics 16SOIC

Parameter	Symbol	Conditions	Min.	Typ.	Max.	Units
Thermal Resistance Junction to Ambient	$\theta_{JA}$	Still air		120		$^{\circ}\text{C}/\text{W}$
	$\theta_{JA}$	1 m/s air flow		115		$^{\circ}\text{C}/\text{W}$
	$\theta_{JA}$	3 m/s air flow		105		$^{\circ}\text{C}/\text{W}$
Thermal Resistance Junction to Case	$\theta_{JC}$			58		$^{\circ}\text{C}/\text{W}$

### Package Outline and Package Dimensions (16-pin SOIC, 150 Mil. Narrow Body)

Package dimensions are kept current with JEDEC Publication No. 95

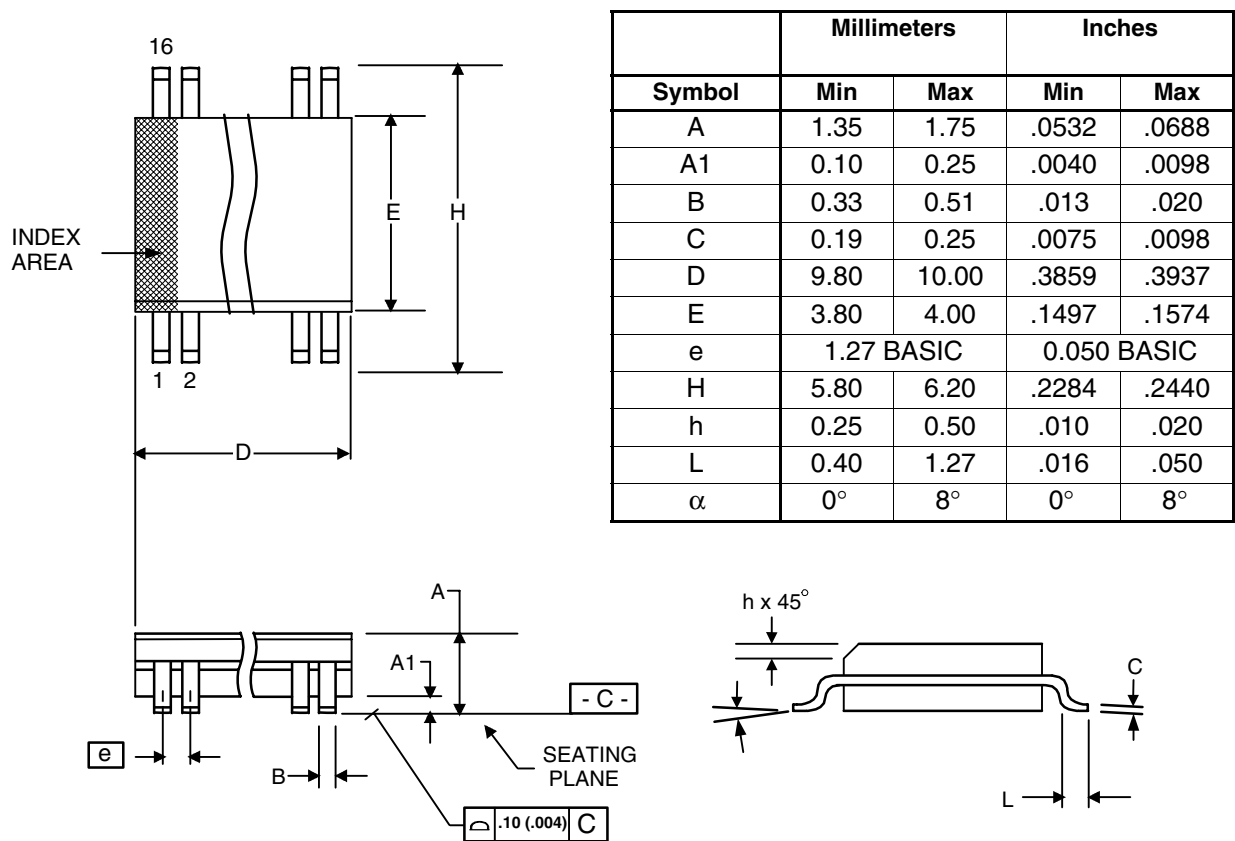

### Package Outline and Package Dimensions (16-pin TSSOP, 4.40 mm Body, 0.65 mm Pitch)

Package dimensions are kept current with JEDEC Publication No. 95

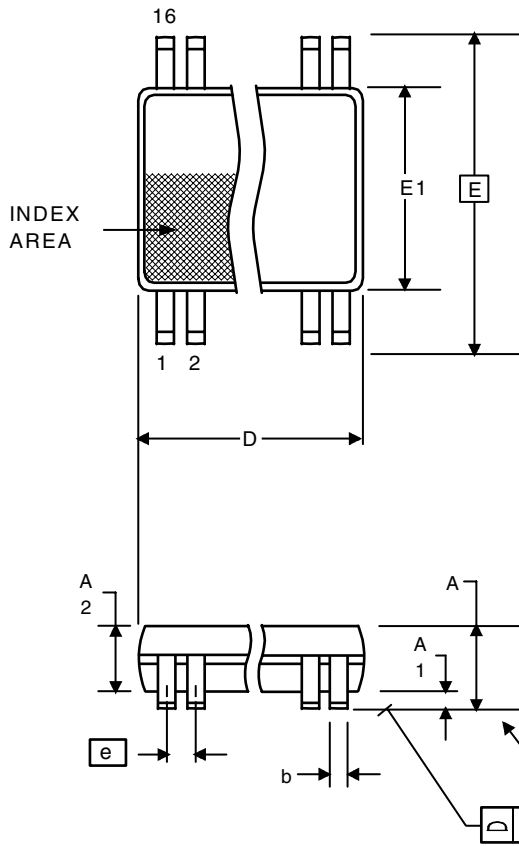

Symbol	Millimeters		Inches	
	Min	Max	Min	Max
A	--	1.20	--	0.047
A1	0.05	0.15	0.002	0.006
A2	0.80	1.05	0.032	0.041
b	0.19	0.30	0.007	0.012
C	0.09	0.20	0.0035	0.008
D	4.90	5.1	0.193	0.201
E	6.40 BASIC		0.252 BASIC	
E1	4.30	4.50	0.169	0.177
e	0.65 Basic		0.0256 Basic	
L	0.45	0.75	0.018	0.030
$\alpha$	0°	8°	0°	8°
aaa	--	0.10	--	0.004

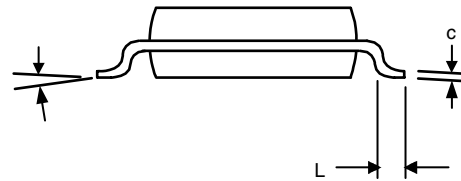

## Ordering Information

Part / Order Number	Marking	Shipping Packaging	Package	Temperature
MK2308S-1HLF	MK2308S-1HLF	Tubes	16-pin SOIC	0 to +70° C
MK2308S-1HLFTR	MK2308S-1HLF	Tape and Reel	16-pin SOIC	0 to +70° C
MK2308G-1HILF	23081HIL	Tubes	16-pin TSSOP	-40 to +85° C
MK2308G-1HILFTR	23081HIL	Tape and Reel	16-pin TSSOP	-40 to +85° C
MK2308G-1HLF	2308G1HL	Tubes	16-pin TSSOP	0 to +70° C
MK2308G-1HLFTR	2308G1HL	Tape and Reel	16-pin TSSOP	0 to +70° C

**"LF" suffix to the part number are the Pb-Free configuration and are RoHS compliant.**

While the information presented herein has been checked for both accuracy and reliability, Integrated Device Technology (IDT) assumes no responsibility for either its use or for the infringement of any patents or other rights of third parties, which would result from its use. No other circuits, patents, or licenses are implied. This product is intended for use in normal commercial applications. Any other applications such as those requiring extended temperature range, high reliability, or other extraordinary environmental requirements are not recommended without additional processing by IDT. IDT reserves the right to change any circuitry or specifications without notice. IDT does not authorize or warrant any IDT product for use in life support devices or critical medical instruments.

MK2308-1H

3.3 VOLT ZERO DELAY, LOW SKEW BUFFER

ZDB



## IMPORTANT NOTICE AND DISCLAIMER

RENESAS ELECTRONICS CORPORATION AND ITS SUBSIDIARIES (“RENESAS”) PROVIDES TECHNICAL SPECIFICATIONS AND RELIABILITY DATA (INCLUDING DATASHEETS), DESIGN RESOURCES (INCLUDING REFERENCE DESIGNS), APPLICATION OR OTHER DESIGN ADVICE, WEB TOOLS, SAFETY INFORMATION, AND OTHER RESOURCES “AS IS” AND WITH ALL FAULTS, AND DISCLAIMS ALL WARRANTIES, EXPRESS OR IMPLIED, INCLUDING, WITHOUT LIMITATION, ANY IMPLIED WARRANTIES OF MERCHANTABILITY, FITNESS FOR A PARTICULAR PURPOSE, OR NON-INFRINGEMENT OF THIRD PARTY INTELLECTUAL PROPERTY RIGHTS.

These resources are intended for developers skilled in the art designing with Renesas products. You are solely responsible for (1) selecting the appropriate products for your application, (2) designing, validating, and testing your application, and (3) ensuring your application meets applicable standards, and any other safety, security, or other requirements. These resources are subject to change without notice. Renesas grants you permission to use these resources only for development of an application that uses Renesas products. Other reproduction or use of these resources is strictly prohibited. No license is granted to any other Renesas intellectual property or to any third party intellectual property. Renesas disclaims responsibility for, and you will fully indemnify Renesas and its representatives against, any claims, damages, costs, losses, or liabilities arising out of your use of these resources. Renesas' products are provided only subject to Renesas' Terms and Conditions of Sale or other applicable terms agreed to in writing. No use of any Renesas resources expands or otherwise alters any applicable warranties or warranty disclaimers for these products.

(Disclaimer Rev.1.0 Mar 2020)

### Corporate Headquarters

TOYOSU FORESIA, 3-2-24 Toyosu,  
Koto-ku, Tokyo 135-0061, Japan  
[www.renesas.com](http://www.renesas.com)

### Contact Information

For further information on a product, technology, the most up-to-date version of a document, or your nearest sales office, please visit:  
[www.renesas.com/contact/](http://www.renesas.com/contact/)

### Trademarks

Renesas and the Renesas logo are trademarks of Renesas Electronics Corporation. All trademarks and registered trademarks are the property of their respective owners.