



MAX1280 Evaluation Kit/Evaluation System

Evaluate: MAX1280

General Description

The MAX1280 evaluation system (EV system) is a complete, 8-channel data-acquisition system consisting of a MAX1280 evaluation kit (EV kit), Maxim 68HC16MODULE-DIP microcontroller (μC) module, and USBTO232. The MAX1280 is a high-speed, multi-channel, 12-bit data-acquisition system. Windows® 98/2000/XP-compatible software provides a handy user interface to exercise the MAX1280's features.

Order the complete EV system (MAX1280EVC16) for a comprehensive evaluation of the MAX1280 using a PC. Order the EV kit (MAX1280EVKIT) if the 68HC16MODULE-DIP module has already been purchased with a previous Maxim EV system, or for custom use in other μC -based systems.

Windows is a registered trademark of Microsoft Corp.

Component Lists

MAX1280 EV System

PART	QTY	DESCRIPTION
MAX1280EVKIT	1	MAX1280 EV kit
68HC16MODULE-DIP	1	68HC16 μC module
USBTO232+	1	USB-to-COM port adapter board

+Denotes lead-free and RoHS-compliant.

MAX1280 EV Kit

DESIGNATION	QTY	DESCRIPTION
C1–C8, C10	9	0.01 μF ceramic capacitors
C9	1	4.7 μF , 10V tantalum capacitor
C11, C13	2	0.1 μF ceramic capacitors
C12, C14	2	10 μF , 10V tantalum capacitors
J1	1	2 x 20 right-angle socket
JU1	1	2-pin header
JU2	1	3-pin header
R1–R8	8	300 Ω \pm 5% resistors
R9, R10	2	10 Ω \pm 1% resistors
TP1	1	8-pin header
U1	1	MAX1280BCUP (20-pin TSOP)
—	1	PCB: MAX1280 Evaluation Kit

MAX1280 EV Kit Files

FILE	DESCRIPTION
INSTALL.EXE	Installs the EV kit files on user's computer
MAX1280.EXE	Application program
KIT1280.C16	Software loaded into 68HC16 μC module

Features

- ◆ Proven PCB Layout
- ◆ Convenient On-Board Test Points
- ◆ Data-Logging Software
- ◆ Fully Assembled and Tested
- ◆ EV Kit Software Supports Windows 98/2000/XP with RS-232/COM Port
- ◆ EV Kit Software Supports Windows 2000/XP with USB Port

Ordering Information

PART	TEMP RANGE	INTERFACE TYPE
MAX1280EVKIT	0°C to +70°C	User supplied
MAX1280EVC16	0°C to +70°C	Windows software

Note: The MAX1280 software is designed for use with the complete MAX1280EVC16 EV system (includes 68HC16MODULE-DIP module, USBTO232, and MAX1280EVKIT). If the MAX1280 evaluation software will not be used, the MAX1280EVKIT board can be purchased by itself, without the μC .

Quick Start

Recommended Equipment (USB Port/PC Connection Option)

Before beginning, the following equipment is needed:

- MAX1280 EV system:
 - MAX1280 EV kit
 - 68HC16MODULE-DIP
 - USBTO232 (USB cable included)
- A small DC power supply, such as a 12VDC, 0.25A plug-in transformer, or a 9V battery
- A user-supplied Windows 2000/XP computer with an available USB port to connect to the USBTO232 board

Note: In the following sections, software-related items are identified by bolding. Text in **bold** refers to items directly from the EV kit software. Text in **bold and underlined** refers to items from the Windows 2000/XP operating system.

Connections and Setup

The MAX1280 EV kit is fully assembled and tested. Follow the steps below to verify board operation. **Caution: Do not turn on the power until all connections are completed.**



MAX1280 Evaluation Kit/Evaluation System

- 1) Visit the Maxim website (www.maxim-ic.com) to download the latest version of the USBTO232 User Guide. Follow the steps in the USBTO232 User Guide *Quick Start* section and return to step 2 of this *Quick Start* section when finished.
- 2) Carefully connect the boards by aligning the 40-pin header of the MAX1280 EV kit with the 40-pin connector of the 68HC16MODULE-DIP module. Gently press them together. The two boards should be flush against one another.
- 3) Ensure that jumper JU1 is closed and jumper JU2 is in the 1-2 position.
- 4) Connect a 7VDC to 20VDC power source to the μ C module at the terminal block located next to the on/off switch, along the top-edge of the μ C module. Observe the polarity marked on the board.
- 5) Connect the USBTO232 board to the 68HC16MODULE-DIP module if you have not done so already.
- 6) The MAX1280 EV kit software should have already been downloaded and installed in the USBTO232 Quick Start.
- 7) Start the MAX1280 program by opening its icon in the **Start | Programs** menu.
- 8) Turn on the power supply and slide SW1 to the ON position on the 68HC16MODULE-DIP module. Press the **OK** button to automatically connect and download the KIT1280.C16 file to the module.
- 9) Apply an input signal between analog common (COM) and input channel CH0. Observe the read-out on the screen.

Recommended Equipment (RS-232-to-COM Port/PC Connection Option)

Before beginning, the following equipment is needed:

- MAX1280 EV system:
 - MAX1280 EV kit
 - 68HC16MODULE-DIP
- A small DC power supply, such as a 12VDC, 0.25A plug-in transformer, or a 9V battery
- A user-supplied Windows 98/2000/XP computer with an available serial (COM) port, preferably a 9-pin plug
- A serial cable to connect the computer's serial port to the 68HC16MODULE-DIP

Connections and Setup

The MAX1280 EV kit is fully assembled and tested. Follow the steps below to verify board operation.

Caution: Do not turn on the power until all connections are completed.

- 1) Visit the Maxim website (www.maxim-ic.com/evkit-software) to download the latest version of the EV kit software. Save the EV kit software to a temporary folder and uncompress the file (if it is a .zip file).
- 2) Install the MAX1280 EV kit software on your computer by running the INSTALL.EXE program. The program files are copied and icons are created for them in the Windows **Start | Programs** menu.
- 3) Carefully connect the boards by aligning the 40-pin header of the MAX1280 EV kit with the 40-pin connector of the 68HC16MODULE-DIP module. Gently press them together. The two boards should be flush against one another.
- 4) Ensure that jumper JU1 is closed and jumper JU2 is in the 1-2 position.
- 5) Connect a 7VDC to 20VDC power source to the μ C module at the terminal block located next to the on/off switch, along the top-edge of the μ C module. Observe the polarity marked on the board.
- 6) Connect a cable from the computer's serial port to the μ C module. If using a 9-pin serial port, use a straight-through, 9-pin female-to-male cable. If the only available serial port uses a 25-pin connector, a standard 25-pin to 9-pin adapter will be required. The EV kit software checks the modem status lines (CTS, DSR, and DCD) to confirm that the correct port has been selected.
- 7) Start the MAX1280 program by opening its icon in the Windows **Start | Programs** menu.
- 8) Turn the power on and slide SW1 to the ON position. The program will automatically download KIT1280.C16 to the module.
- 9) Apply an input signal between analog common (COM) and input channel CH0. Observe the read-out on the screen.

Detailed Description

MAX1280 Stand-Alone EV Kit

The MAX1280 EV kit provides a proven printed-circuit board (PCB) layout to evaluate the MAX1280. It must be interfaced to appropriate timing signals for proper operation. Connect +5V to VDD1 and VDD2, and connect the ground return to GND. See the MAX1280 EV kit schematic (Figure 1). Refer to the MAX1280 IC data sheet for timing requirements.

MAX1280 Evaluation Kit/Evaluation System

Evaluate: MAX1280

MAX1280 EV System

The MAX1280 EV system operates from a user-supplied 7VDC to 20VDC power supply. Windows 98/2000/XP-compatible software running on a PC interfaces to the EV system board through the computer's serial communications port. See the *Recommended Equipment* and *Connections and Setup* sections for setup and operating instructions.

Description of Software

The evaluation software's main window controls the active control word bits, serial clock speed, and sample rate. It displays the voltage and output code for each active channel, as well as some statistics of the input signal. A separate graph window shows the data changing in real time. The update rate is limited to about 10 samples per second due to COM port bandwidth limitations.

Controls

The control word is divided into several fields. To change the active control word, drop down the appropriate field's combo box and select the desired option. If the QSPI™ clock is set to **STOP**, then configuration data will not be sent until the **READ** button is clicked.

Statistics

The **Minimum** and **Maximum** fields show the highest and lowest readings acquired. The **Average** field shows a running mean based on the equation $a_i = (k)(x_i) + (1 - k)(a_{i-1})$. The **Clear** button resets the statistics. To remove offset errors, first apply 0V to the active input channel, clear statistics, acquire some samples, and then check **Tare**. This average offset voltage will now be subtracted from all subsequent measurements.

Sampling

Choose the desired sampling rate (QSPI Clock), sampling size (**Sample!** menu item), click **Begin Sampling!** (in **Sample!** pop-up window). Sample size is restricted to a power of 2 to permit FFT processing once the data is saved to a file. After the samples have been collected, the data is automatically uploaded to the host and is graphed. Once displayed, the data can optionally be saved to a file.

Saving Graphs to Disk

Data in the real-time graph and in sampled data graphs may be saved to a file. Only the raw output codes are saved, but voltages may be inferred, based on the reference voltage and the maximum code value.

QSPI is a trademark of Motorola, Inc.

Scanning All Channels

To scan through all channels, select **SCAN** from the **INPUT** menu.

Evaluating Shutdown

The evaluation software configures the 68HC16's QSPI submodule to continuously read data from the MAX1280 into the 68HC16. The sample rate is controlled by the QSPI clock. To evaluate power-saving modes, these automatic updates must be stopped. First, set the QSPI clock control to **STOP**. This reconfigures the 68HC16's QSPI submodule to stop driving the serial clock. Second, in the evaluation software's main window, uncheck the **Read Every...msec** checkbox. Next, choose the desired software power-down control word, and click the **Read** button to send the new configuration to the MAX1280. Or, if evaluating the hardware shutdown, move jumper JU2 to the 2-3 position. Sense the supply current by measuring the voltage across resistors R9 and R10.

Reference Voltage

The evaluation software assumes a 2.5V reference voltage, unless otherwise specified. Refer to the MAX1280 IC data sheet for more information. To override this value, type the new reference voltage into the **Vref** edit box and click the **Set Vref** button.

Description of Hardware

U1, the MAX1280, is a high-speed, multichannel, 12-bit data-acquisition system. Resistors R1–R8 and capacitors C1–C8 form single-pole, lowpass anti-aliasing filters with a nominal 3ms time constant and approximately a 50kHz corner frequency. Jumper JU1 connects the analog common (COM) to ground (GND). C10 bypasses the bandgap reference, and C9 bypasses the analog-to-digital converter's (ADC's) voltage reference. When plugged into the 68HC16MODULE, VDD1 and VDD2 are both powered by +5V. See the MAX1280 EV kit schematic (Figure 1) and refer to the MAX1280 IC data sheet.

Table 1. Jumper Functions

JUMPER	POSITION	FUNCTION
JU1	Closed*	COM is connected to GND
	Open	COM is disconnected from GND. All analog inputs, including COM, must still be within the MAX1280's common-mode input range.
JU2	1-2*	Operate
	2-3	Shutdown

*Default position.

MAX1280 Evaluation Kit/Evaluation System

Measuring Supply Current

Power-supply current can be monitored by measuring the voltage across resistor R9 (for VDD1) or R10 (VDD2). These resistors are $10\Omega \pm 1\%$, so every 0.001V across R9 represents 100 μ A of supply current.

Troubleshooting

Problem: No output measurement. System seems to report zero voltage or fails to make a measurement.

- 1) Check VDD1 and VDD2 supply voltages.
- 2) Check the 2.5V reference voltage using a DVM.

- 3) Verify with an oscilloscope that the conversion-start signal is being strobed.
- 4) Verify that $\overline{\text{SHDN}}$ is being driven high.

Problem: Measurements are erratic, unstable; poor accuracy.

- 1) Check the reference voltage using a DVM.
- 2) Use an oscilloscope to check for noise. When probing for noise, keep the oscilloscope ground return lead as short as possible, preferably less than 1/2in (10mm).

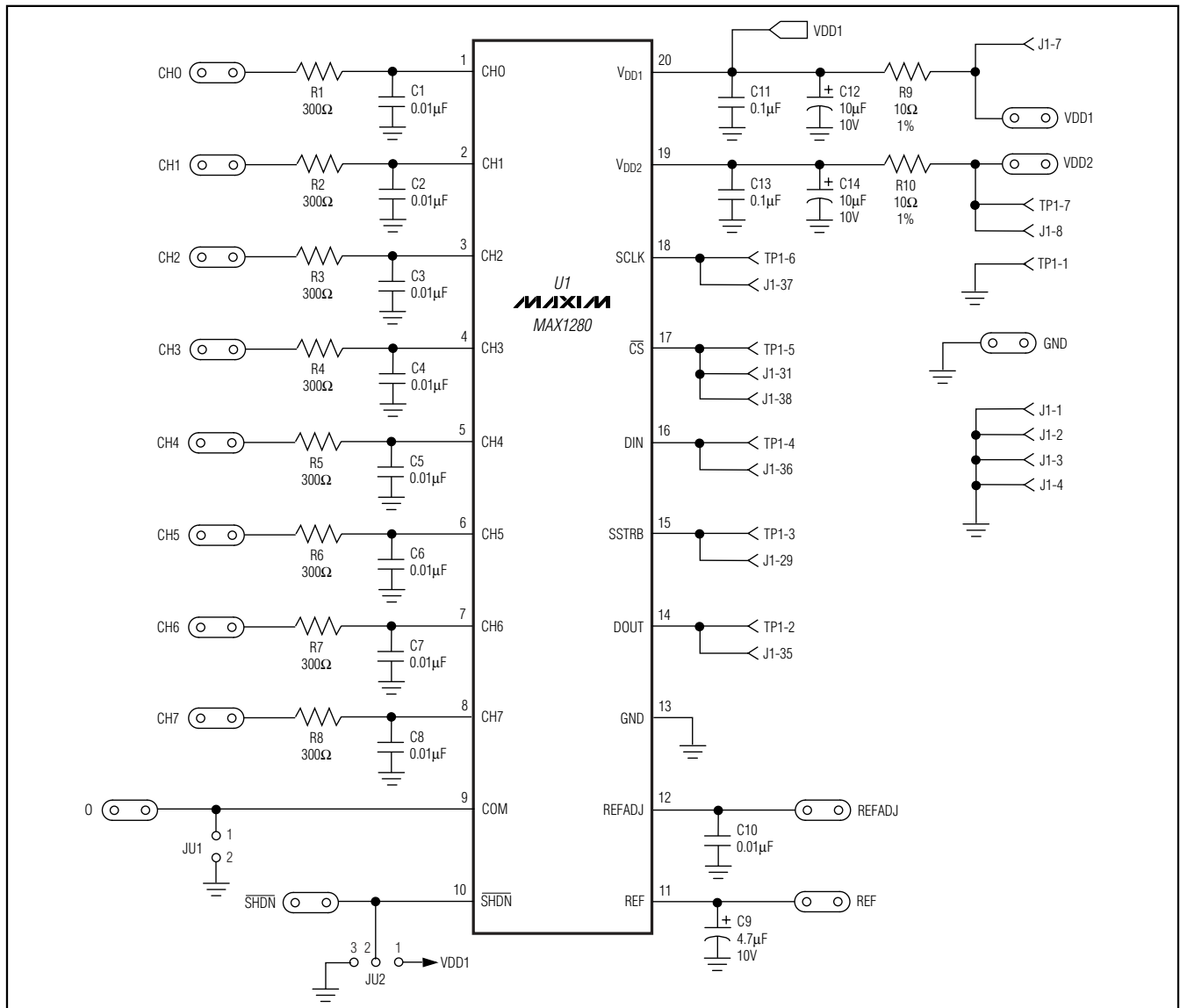

Figure 1. MAX1280 EV Kit Schematic

MAX1280 Evaluation Kit/Evaluation System

Evaluate: MAX1280

```
Init: LDAA #$08          ; CS high, clock low by default
      STAA QPDR
      LDAA #$0F
      STAA QPAR          ; pins that are assigned to the QSPI
      LDAA #$0E
      STAA QDDR          ; QSM pins that are outputs
      LDAA #$80          ; CRCONT
      STAA CR0           ; send eight-bit control word, and continue...
      STAA CR2
      STAA CR4
      ...
      STAA CRE
      LDAA #$40          ; (CRBITSE)
      STAA CR1           ; receive sixteen-bit data field
      STAA CR3
      STAA CR5
      ...
      STAA CRF
      CLRD              ; send zero when receiving data
      STD  TR1
      STD  TR3
      STD  TR5
      ...
      STD  TRF
      LDAB #%10001111    ; channel 0, unipolar, single-ended, pd=11
      std  TR0            ; channel 0 command
      ldab #$40          ; channel 1 bit mask
      ord  TR0
      std  TR2            ; channel 1 command
      ldab #$10          ; channel 2 bit mask
      ord  TR0
      std  TR4            ; channel 2 command
      ...
      ldab #$70          ; channel 7 bit mask
      ord  TR0
      std  TRE            ; channel 7 command
      CLR  SPCR3          ; disable QSPI halt mode interrupt
      LDD  #$8008        ; BITS=16, SPBR=8 (1.049 MHz), CPOL=0, CPHA=0
      STD  SPCR0
      LDD  #$0204        ; DSCK, DTL not used
      STD  SPCR1
      LDD  #$4F00        ; newqp=0, endqp=15, wrap to zero
      STD  SPCR2          ; run QSPI continuously on all channels
      BSETW SPCR1,$$8000 ; start the QSPI
      BCLR  SPSR,$$80    ; clear SPIF bit

ReadLoop:
      LDD  RR1
      jsr  Process_Channel_0
      LDD  RR3
      jsr  Process_Channel_1
      LDD  RR5
      jsr  Process_Channel_2
      ...
      LDD  RRF
      jsr  Process_Channel_7
      jmp  ReadLoop
```

Example 1. Reading All Channels with QSPI

MAX1280 Evaluation Kit/Evaluation System

```
Init: LDAA #$08          ; CS high, clock low by default
      STAA QPDR
      LDAA #$0F
      STAA QPAR          ; pins that are assigned to the QSPI
      LDAA #$0E
      STAA QDDR          ; QSM pins that are outputs
      LDAA #$80          ; CRCONT
      STAA CR0           ; send eight-bit control word, and continue...
      LDAA #$40          ; (CRBITSE)
      STAA CR1           ; receive sixteen-bit data field
      CLR D               ; send zero when receiving data
      STD  TR1
      LDAB #%10001111    ; channel 0, unipolar, single-ended, pd=11
      std  TR0           ; channel 0 command
      CLR  SPCR3         ; disable QSPI halt mode interrupt
      LDD  #$8008        ; BITS=16, SPBR=8 (1.049 MHz), CPOL=0, CPHA=0
      STD  SPCR0
      LDD  #$0204        ; DSCK, DTL not used
      STD  SPCR1
      LDD  #$0100        ; newqp=0, endqp=1, no wrap
      STD  SPCR2
ReadLoop:
      BSETW SPCR1,$$8000 ; start the QSPI
      BCLR  SPSR,$$80    ; clear SPIF bit
Idle: BRCLR SPSR,$$80,Idle ; wait until SPIF bit is set
      LDD  RR1
      ROLD
      ROLD
      ROLD
      jsr  Process_Channel_0
      jmp  ReadLoop
```

Example 2. Reading a Single Channel with QSPI

MAX1280 Evaluation Kit/Evaluation System

Evaluate: MAX1280

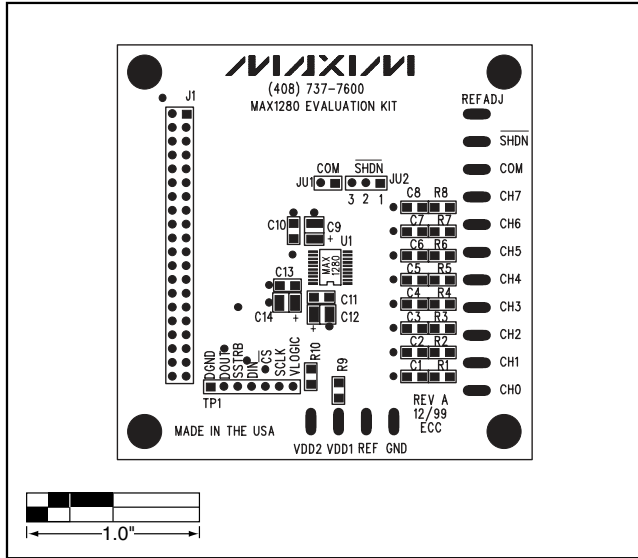

Figure 2. MAX1280 EV Kit Component Placement Guide—Component Side

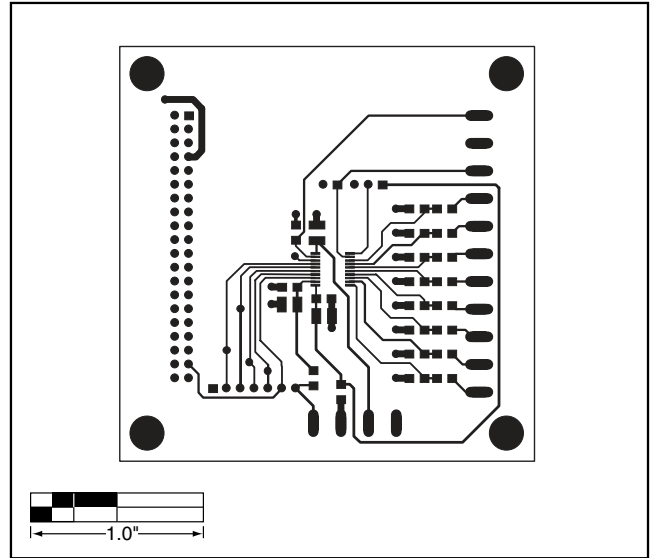

Figure 3. MAX1280 EV Kit PCB Layout—Component Side

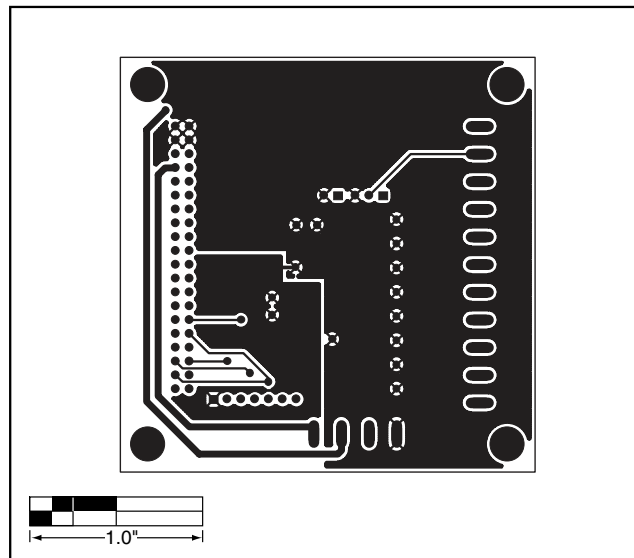

Figure 4. MAX1280 EV Kit PCB Layout—Solder Side

Revision History

Pages changed at Rev 1: Title change—all pages, 1–4, 7, 8

Maxim cannot assume responsibility for use of any circuitry other than circuitry entirely embodied in a Maxim product. No circuit patent licenses are implied. Maxim reserves the right to change the circuitry and specifications without notice at any time.

Maxim Integrated Products, 120 San Gabriel Drive, Sunnyvale, CA 94086 408-737-7600 _____ 7