

**NOT RECOMMENDED FOR NEW DESIGNS  
RECOMMENDED REPLACEMENT PART  
ISL54050**

**ISL54504, ISL54505**

# + 1.8V to + 5.5V, 2.5Ω, Single SPST Analog Switches

## ISL54504, ISL54505

The Intersil ISL54504 and ISL54505 devices are low ON-resistance, low voltage, bidirectional, single pole/single throw (SPST) analog switches designed to operate from a single +1.8V to +5.5V supply. Targeted applications include battery powered equipment that benefit from low  $r_{ON}$  resistance (2.5Ω), excellent  $r_{ON}$  flatness (0.6Ω), and fast switching speeds ( $t_{ON}$  = 25ns,  $t_{OFF}$  = 15ns). The digital logic input is 1.8V CMOS compatible when using a single +3V supply.

Cell phones, for example, often face ASIC functionality limitations. The number of analog input or GPIO pins may be limited and digital geometries are not well suited to analog switch performance. This family of parts may be used to switch in additional functionality while reducing ASIC design risk. The ISL54504 and ISL54505 are offered in a 6 Ld 1.2mmx1.0mmx0.4mm pitch μTDFN package and a 6 Ld SOT-23 package, alleviating board space limitations.

The ISL54504 has one normally open (NO) switch and ISL54505 has one normally closed (NC) switch.

TABLE 1. FEATURES AT A GLANCE

	ISL54504	ISL54505
Number of Switches	1	1
SW	NO	NC
1.8V $r_{ON}$	6Ω	6Ω
1.8V $t_{ON}/t_{OFF}$	65ns/40ns	65ns/40ns
3V $r_{ON}$	4Ω	4Ω
3V $t_{ON}/t_{OFF}$	30ns/20ns	30ns/20ns
5V $r_{ON}$	2.5Ω	2.5Ω
5V $t_{ON}/t_{OFF}$	25ns/15ns	25ns/15ns
Package	6 Ld μTDFN, 6 Ld SOT-23	

## Features

- ON-resistance ( $r_{ON}$ )
  - $V_{CC}$  = +5.0V. . . . . 2.5Ω
  - $V_{CC}$  = +3.0V. . . . . 4.0Ω
  - $V_{CC}$  = +1.8V. . . . . 7.0Ω
- $r_{ON}$  flatness (+4.5V Supply) . . . . . 0.6Ω
- Single supply operation . . . . . +1.8V to +5.5V
- Fast switching action (+4.5V Supply)
  - $t_{ON}$  . . . . . 25ns
  - $t_{OFF}$ . . . . . 15ns
- ESD HBM rating . . . . . 6kV
- 1.8V CMOS logic compatible (+3V supply)
- Available in 6 Ld μTDFN and 6Ld SOT-23 Packages
- Pb-free available (RoHS compliant)

## Applications

- Battery powered, handheld, and portable equipment
  - Cellular/mobile phones
  - Pagers
  - Laptops, notebooks, palmtops
- Portable Test and Measurement
- Medical Equipment
- Audio and video switching

## Related Literature

- Technical Brief TB363 "Guidelines for Handling and Processing Moisture Sensitive Surface Mount Devices (SMDs)"

This is a Pre-Development Preliminary Datasheet. Device functionality and specifications are subject to change

## Ordering Information

PART NUMBER (Notes 1, 4)	PART MARKING	TEMP. RANGE (°C)	PACKAGE (Tape and Reel) (Pb-Free)	PKG. DWG. #
ISL54504IRUZ-T (Note 2)	4	-40 to +85	6 Ld $\mu$ TDFN	L6.1.2x1.0A
ISL54504IHZ-T (Note 3)	4504	-40 to +85	6 Ld SOT-23	MDP0038
ISL54505IRUZ-T (Note 2)	5	-40 to +85	6 Ld $\mu$ TDFN	L6.1.2x1.0A
ISL54505IHZ-T (Note 3)	4505	-40 to +85	6 Ld SOT-23	MDP0038

**NOTES:**

1. Please refer to [TB347](#) for details on reel specifications.
2. These Intersil Pb-free plastic packaged products employ special Pb-free material sets; molding compounds/die attach materials and NiPdAu plate - e4 termination finish, which is RoHS compliant and compatible with both SnPb and Pb-free soldering operations. Intersil Pb-free products are MSL classified at Pb-free peak reflow temperatures that meet or exceed the Pb-free requirements of IPC/JEDEC J STD-020.
3. These Intersil Pb-free plastic packaged products employ special Pb-free material sets, molding compounds/die attach materials, and 100% matte tin plate plus anneal (e3 termination finish, which is RoHS compliant and compatible with both SnPb and Pb-free soldering operations). Intersil Pb-free products are MSL classified at Pb-free peak reflow temperatures that meet or exceed the Pb-free requirements of IPC/JEDEC J STD-020.
4. For Moisture Sensitivity Level (MSL), please see device information page for [ISL54504](#), [ISL54505](#). For more information on MSL please see techbrief [TB363](#).

## Pin Configurations (Note 5)

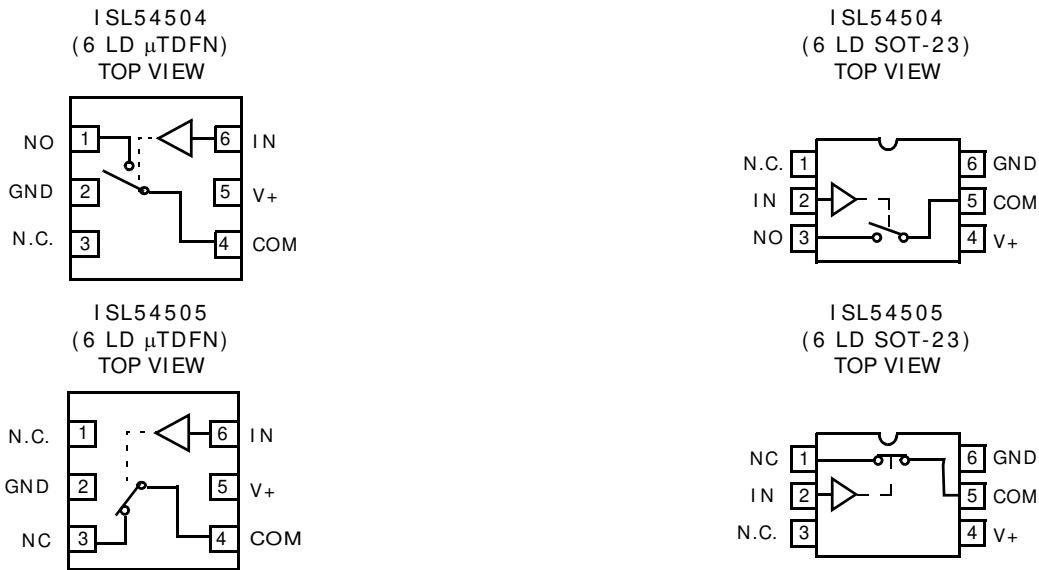

**NOTE:**

5. Switches Shown for Logic "0" Input.

## Truth Table

LOGIC	ISL54504	ISL54505
0	Off	On
1	On	Off

NOTE: Logic "0"  $\leq 0.5V$ . Logic "1"  $\geq 1.4V$  with a 3V supply.

## Pin Descriptions

PIN NAME	FUNCTION
V+	System Power Supply Input (+1.8V to +5.5V)
GND	Ground Connection
IN	Digital Control Input
COM	Analog Switch Common Pin
NO	Analog Switch Normally Open Pin
NC	Analog Switch Normally Closed Pin
N.C.	No Connect

**Absolute Maximum Ratings**

V+ to GND	-0.5V to 6.5V
Input Voltages	
NO, NC, IN (Note 4)	-0.5V to ((V+) + 0.5V)
Output Voltages	
COM (Note 4)	-0.5V to ((V+) + 0.5V)
Continuous Current NO, NC, or COM	±300mA
Peak Current NO, NC, or COM (Pulsed 1ms, 10% Duty Cycle, Max)	±600mA
ESD Rating	
Human Body Model	> 6kV
Machine Model	> 300V
Charged Device Model	> 2.2kV

**Thermal Information**

Thermal Resistance (Typical)	$\theta_{JA}$ (°C/W)	$\theta_{JC}$ (°C/W)
6 Ld $\mu$ TDFN Package (Notes 7, 9)	239.2	111.6
6 Ld SOT-23 Package (Note 8, 10)	260	120
Maximum Junction Temperature (Plastic Package)	+150°C	
Maximum Storage Temperature Range	-65°C to +150°C	
Pb-free Reflow Profile	see link below <a href="http://www.intersil.com/pbfree/Pb-FreeReflow.asp">http://www.intersil.com/pbfree/Pb-FreeReflow.asp</a>	

**Operating Conditions**

V+ (Positive DC Supply Voltage)	1.8V to 5.5V
Analog Signal Range	0V to V+
V <sub>IN</sub> (Digital Logic Input Voltage (IN))	0V to V+
Temperature Range	-40°C to +85°C

*CAUTION: Do not operate at or near the maximum ratings listed for extended periods of time. Exposure to such conditions may adversely impact product reliability and result in failures not covered by warranty.*

**NOTES:**

- Signals on NC, NO, IN, or COM exceeding V+ or GND are clamped by internal diodes. Limit forward diode current to maximum current ratings.
- $\theta_{JA}$  is measured in free air with the component mounted on a high effective thermal conductivity test board with “direct attach” features. See Tech Brief TB379.
- $\theta_{JA}$  is measured with the component mounted on a high effective thermal conductivity test board in free air. See Tech Brief TB379 for details.
- For  $\theta_{JC}$ , the “case temp” location is the center of the exposed metal pad on the package underside.
- For  $\theta_{JC}$ , the “case temp” location is taken at the package top center.

**Electrical Specifications - 5V Supply**

Test Conditions: V+ = +4.5V to +5.5V, GND = 0V, V<sub>INH</sub> = 2.0V, V<sub>INL</sub> = 0.8V (Note 11), Unless Otherwise Specified. Boldface limits apply over the operating temperature range, -40°C to +85°C.

PARAMETER	TEST CONDITIONS	TEMP (°C)	MIN (Notes 12, 13)	TYP	MAX (Notes 12, 13)	UNITS
<b>ANALOG SWITCH CHARACTERISTICS</b>						
Analog Signal Range, V <sub>ANALOG</sub>		Full	0	-	V+	V
ON-Resistance, r <sub>ON</sub>	V+ = 4.5V, I <sub>COM</sub> = 100mA, V <sub>NO</sub> or V <sub>NC</sub> = 0V to V+, (Note 15, See Figure 4)	25	-	2.2	2.5	$\Omega$
		Full	-	-	3	$\Omega$
r <sub>ON</sub> Flatness, r <sub>FLAT(ON)</sub>	V+ = 4.5V, I <sub>COM</sub> = 100mA, V <sub>NO</sub> or V <sub>NC</sub> = 0V to V+, (Notes 14, 15)	25	-	0.6	0.65	$\Omega$
		Full	-	-	0.7	$\Omega$
NO or NC OFF Leakage Current, I <sub>NO(OFF)</sub> or I <sub>NC(OFF)</sub>	V+ = 5.5V, V <sub>COM</sub> = 0.3V, 5V, V <sub>NO</sub> or V <sub>NC</sub> = 5V, 0.3V	25	-25	1.5	25	nA
		Full	-150	-	150	nA
COM ON Leakage Current, I <sub>COM(ON)</sub>	V+ = 5.5V, V <sub>COM</sub> = 0.3V, 5V, or V <sub>NO</sub> or V <sub>NC</sub> = 0.3V, 5V, or Floating	25	-30	2.8	30	nA
		Full	-300	-	300	nA
<b>DYNAMIC CHARACTERISTICS</b>						
Turn-ON Time, t <sub>ON</sub>	V+ = 4.5V, V <sub>NO</sub> or V <sub>NC</sub> = 3.0V, R <sub>L</sub> = 50 $\Omega$ , C <sub>L</sub> = 35pF (See Figure 1, Note 15)	25	-	25	-	ns
		Full	-	25	-	ns
Turn-OFF Time, t <sub>OFF</sub>	V+ = 4.5V, V <sub>NO</sub> or V <sub>NC</sub> = 3.0V, R <sub>L</sub> = 50 $\Omega$ , C <sub>L</sub> = 35pF (See Figure 1, Note 15)	25	-	15	-	ns
		Full	-	16	-	ns
Break-Before-Make Time Delay, t <sub>D</sub>	V+ = 5.5V, V <sub>NO</sub> or V <sub>NC</sub> = 3.0V, R <sub>L</sub> = 50 $\Omega$ , C <sub>L</sub> = 35pF (See Figure 3, Note 15)	Full	-	15	-	ns
Charge Injection, Q	V <sub>G</sub> = 0V, R <sub>G</sub> = 0 $\Omega$ , C <sub>L</sub> = 1.0nF (See Figure 2)	25	-	24	-	pC
OFF Isolation	R <sub>L</sub> = 50 $\Omega$ , C <sub>L</sub> = 5pF, f = 1MHz, V <sub>COM</sub> = 1V <sub>P-P</sub> (See Figure 3)	25	-	70	-	dB

**Electrical Specifications - 5V Supply**

Test Conditions:  $V_+ = +4.5V$  to  $+5.5V$ ,  $GND = 0V$ ,  $V_{INH} = 2.0V$ ,  $V_{INL} = 0.8V$  (Note 11), Unless Otherwise Specified. Boldface limits apply over the operating temperature range,  $-40^\circ C$  to  $+85^\circ C$ . (Continued)

PARAMETER	TEST CONDITIONS	TEMP (°C)	MIN (Notes 12, 13)	TYP	MAX (Notes 12, 13)	UNITS
Total Harmonic Distortion	$f = 20Hz$ to $20kHz$ , $V_{COM} = 2V_{P-P}$ $R_L = 32\Omega$	25	-	0.15	-	%
Total Harmonic Distortion	$f = 20Hz$ to $20kHz$ , $V_{COM} = 2V_{P-P}$ $R_L = 600\Omega$	25	-	0.014	-	%
-3dB Bandwidth	Signal = 0dBm, $R_L = 50\Omega$	25	-	250	-	MHz
NO or NC OFF Capacitance, $C_{OFF}$	$V_+ = 4.5V$ , $f = 1MHz$ , $V_{NO}$ or $V_{NC} = V_{COM} = 0V$ (See Figure 5)	25	-	7	-	pF
COM ON Capacitance, $C_{COM(ON)}$	$V_+ = 4.5V$ , $f = 1MHz$ , $V_{NO}$ or $V_{NC} = V_{COM} = 0V$ (See Figure 5)	25	-	18	-	pF
<b>POWER SUPPLY CHARACTERISTICS</b>						
Power Supply Range		Full	1.8	-	5.5	V
Positive Supply Current, $I_+$	$V_+ = 5.5V$ , $V_{IN} = 0V$ or $V_+$	25	-	0.028	0.1	$\mu A$
		Full	-	1.1	2.5	$\mu A$
<b>DIGITAL INPUT CHARACTERISTICS</b>						
Input Voltage Low, $V_{INL}$		Full	-	-	0.8	V
Input Voltage High, $V_{INH}$		Full	2.4	-	-	V
Input Current, $I_{INH}$ , $I_{INL}$	$V_+ = 5.5V$ , $V_{IN} = 0V$ or $V_+$	Full	-0.1	0.053	0.1	$\mu A$

**Electrical Specifications - 3V Supply**

Test Conditions:  $V_+ = +2.7V$  to  $+3.6V$ ,  $GND = 0V$ ,  $V_{INH} = 1.4V$ ,  $V_{INL} = 0.5V$  (Note 11), Unless Otherwise Specified. Boldface limits apply over the operating temperature range,  $-40^\circ C$  to  $+85^\circ C$ .

PARAMETER	TEST CONDITIONS	TEMP (°C)	MIN (Notes 12, 13)	TYP	MAX (Notes 12, 13)	UNITS
<b>ANALOG SWITCH CHARACTERISTICS</b>						
Analog Signal Range, $V_{ANALOG}$		Full	0	-	$V_+$	V
ON-Resistance, $r_{ON}$ $\mu TDFN$	$V_+ = 2.7V$ , $I_{COM} = 100mA$ , $V_{NO}$ or $V_{NC} = 0V$ to $V_+$ , (Note 15, See Figure 4)	25	-	3.3	3.5	$\Omega$
		Full	-	-	4.5	$\Omega$
ON-Resistance, $r_{ON}$ SOT-23	$V_+ = 2.7V$ , $I_{COM} = 100mA$ , $V_{NO}$ or $V_{NC} = 0V$ to $V_+$ , (Note 15, See Figure 4)	25	-	3.3	3.6	$\Omega$
		Full	-	-	4.5	$\Omega$
$r_{ON}$ Flatness, $r_{FLAT(ON)}$ $\mu TDFN$	$V_+ = 2.7V$ , $I_{COM} = 100mA$ , $V_{NO}$ or $V_{NC} = 0V$ to $V_+$ , (Notes 7, 15)	25	-	1	1.1	$\Omega$
		Full	-	-	1.2	$\Omega$
$r_{ON}$ Flatness, $r_{FLAT(ON)}$ SOT-23	$V_+ = 2.7V$ , $I_{COM} = 100mA$ , $V_{NO}$ or $V_{NC} = 0V$ to $V_+$ , (Notes 7, 15)	25	-	1	1.2	$\Omega$
		Full	-	-	1.3	$\Omega$
<b>DYNAMIC CHARACTERISTICS</b>						
Turn-ON Time, $t_{ON}$	$V_+ = 2.7V$ , $V_{NO}$ or $V_{NC} = 1.5V$ , $R_L = 50\Omega$ , $C_L = 35pF$ (See Figure 1, Note 15)	25	-	30	-	ns
		Full	-	30	-	ns
Turn-OFF Time, $t_{OFF}$	$V_+ = 2.7V$ , $V_{NO}$ or $V_{NC} = 1.5V$ , $R_L = 50\Omega$ , $C_L = 35pF$ (See Figure 1, Note 15)	25	-	20	-	ns
		Full	-	20	-	ns
Charge Injection, Q	$V_G = 0V$ , $R_G = 0\Omega$ , $C_L = 1.0nF$ (See Figure 2)	25	-	16	-	pC
OFF Isolation	$R_L = 50\Omega$ , $C_L = 5pF$ , $f = 1MHz$ , $V_{COM} = 1V_{P-P}$ (See Figure 3)	25	-	-70	-	dB
Total Harmonic Distortion	$f = 20Hz$ to $20kHz$ , $V_{COM} = 2V_{P-P}$ $R_L = 32\Omega$	25	-	0.36	-	%
Total Harmonic Distortion	$f = 20Hz$ to $20kHz$ , $V_{COM} = 2V_{P-P}$ $R_L = 600\Omega$	25	-	0.03	-	%

# ISL54504, ISL54505

## Electrical Specifications - 3V Supply

Test Conditions:  $V_+ = +2.7V$  to  $+3.6V$ ,  $GND = 0V$ ,  $V_{INH} = 1.4V$ ,  $V_{INL} = 0.5V$  (Note 11), Unless Otherwise Specified. Boldface limits apply over the operating temperature range,  $-40^\circ C$  to  $+85^\circ C$ . (Continued)

PARAMETER	TEST CONDITIONS	TEMP (°C)	MIN (Notes 12, 13)	TYP	MAX (Notes 12, 13)	UNITS
-3dB Bandwidth	Signal = 0dBm, $R_L = 50\Omega$	25	-	250	-	MHz
NO or NC OFF Capacitance, $C_{OFF}$	$f = 1MHz$ , $V_{NO}$ or $V_{NC} = V_{COM} = 0V$ (See Figure 5)	25	-	6	-	pF
COM OFF Capacitance, $C_{COM(OFF)}$	$f = 1MHz$ , $V_{NO}$ or $V_{NC} = V_{COM} = 0V$ (See Figure 5)	25	-	15	-	pF
COM ON Capacitance, $C_{COM(ON)}$	$f = 1MHz$ , $V_{NO}$ or $V_{NC} = V_{COM} = 0V$ (See Figure 5)	25	-	18	-	pF
<b>POWER SUPPLY CHARACTERISTICS</b>						
Positive Supply Current, $I_+$	$V_+ = 3.6V$ , $V_{IN} = 0V$ or $V_+$	25	-	0.013	-	$\mu A$
		Full	-	0.7	-	$\mu A$
<b>DIGITAL INPUT CHARACTERISTICS</b>						
Input Voltage Low, $V_{INL}$		Full	-	-	0.5	V
Input Voltage High, $V_{INH}$		Full	1.4	-	-	V
Input Current, $I_{INH}$ , $I_{INL}$	$V_+ = 3.6V$ , $V_{IN} = 0V$ or $V_+$	Full	-0.1	0.058	0.1	$\mu A$

## Electrical Specifications - 1.8V Supply

Test Conditions:  $V_+ = +1.8V$ ,  $GND = 0V$ ,  $V_{INH} = 1V$ ,  $V_{INL} = 0.4V$  (Note 11), Unless Otherwise Specified. Boldface limits apply over the operating temperature range,  $-40^\circ C$  to  $+85^\circ C$ .

PARAMETER	TEST CONDITIONS	TEMP (°C)	MIN (Notes 12, 13)	TYP	MAX (Notes 12, 13)	UNITS
<b>ANALOG SWITCH CHARACTERISTICS</b>						
Analog Signal Range, $V_{ANALOG}$		Full	0	-	$V_+$	V
ON-Resistance, $r_{ON}$	$V_+ = 1.8V$ , $I_{COM} = 10mA$ , $V_{NO}$ or $V_{NC} = 0V$ to $V_+$ (Note 15, See Figure 4)	25	-	6	6.5	$\Omega$
		Full	-	-	7	$\Omega$
<b>DYNAMIC CHARACTERISTICS</b>						
Turn-ON Time, $t_{ON}$	$V_+ = 1.8V$ , $V_{NO}$ or $V_{NC} = 1.5V$ , $R_L = 50\Omega$ , $C_L = 35pF$ (See Figure 1, Note 15)	25	-	65	-	ns
		Full	-	95	-	ns
Turn-OFF Time, $t_{OFF}$	$V_+ = 1.8V$ , $V_{NO}$ or $V_{NC} = 1.5V$ , $R_L = 50\Omega$ , $C_L = 35pF$ (See Figure 1, Note 15)	25	-	40	-	ns
		Full	-	65	-	ns
Charge Injection, Q	$V_G = V_+/2$ , $R_G = 0\Omega$ , $C_L = 1.0nF$ (See Figure 2)	25	-	8.2	-	pC
<b>DIGITAL INPUT CHARACTERISTICS</b>						
Input Voltage Low, $V_{INL}$		Full	-	-	0.4	V
Input Voltage High, $V_{INH}$		Full	1	-	-	V

### NOTES:

11.  $V_{IN}$  = input voltage to perform proper function.
12. The algebraic convention, whereby the most negative value is a minimum and the most positive a maximum, is used in this data sheet.
13. Parts are 100% tested at  $+25^\circ C$ . Over-temperature limits established by characterization and are not production tested.
14. Flatness is defined as the difference between maximum and minimum value of on-resistance over the specified analog signal range.
15. Limits established by characterization and are not production tested.

## Test Circuits and Waveforms

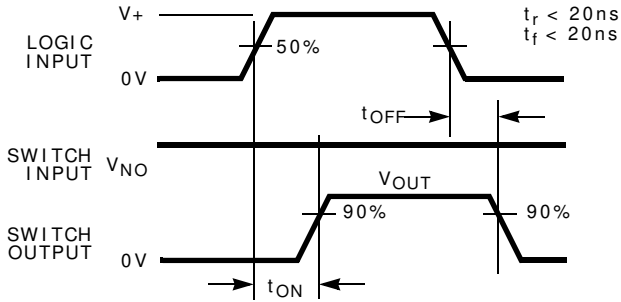

Logic input waveform is inverted for switches that have the opposite logic sense.

FIGURE 1A. MEASUREMENT POINTS

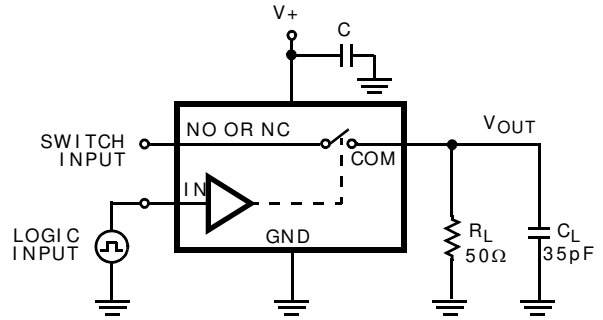

Repeat test for all switches.  $C_L$  includes fixture and stray capacitance.

$$V_{OUT} = V_{(NO \text{ or } NC)} \frac{R_L}{R_L + r_{(ON)}}$$

FIGURE 1B. TEST CIRCUIT

FIGURE 1. SWITCHING TIMES

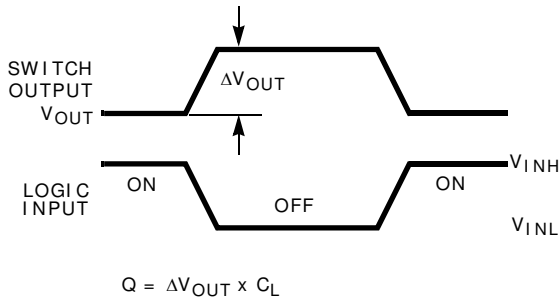

FIGURE 2A. MEASUREMENT POINTS

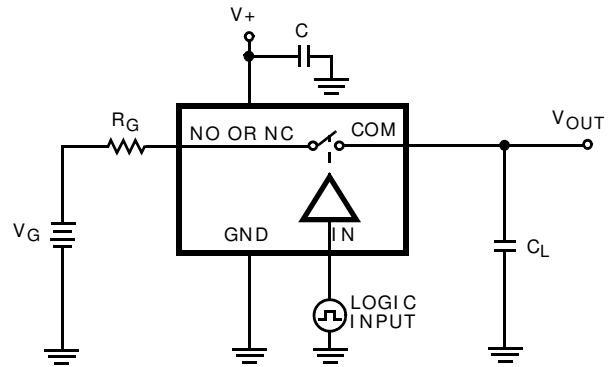

FIGURE 2B. TEST CIRCUIT

FIGURE 2. CHARGE INJECTION

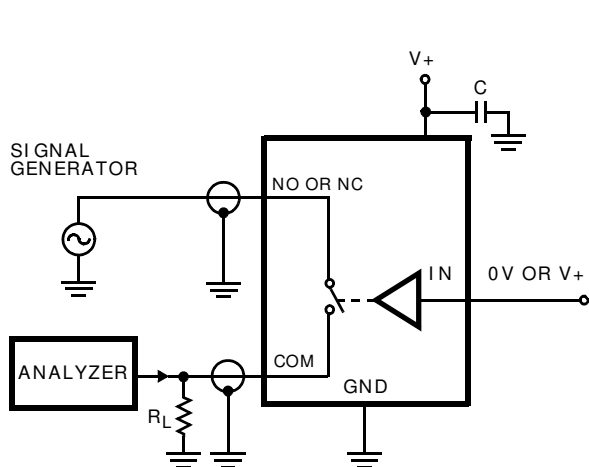
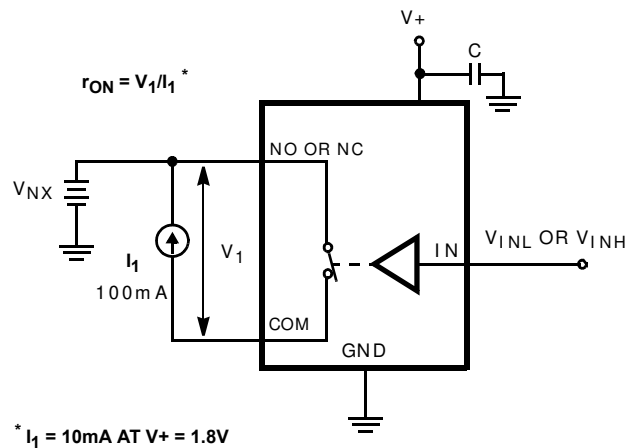

FIGURE 3. OFF ISOLATION TEST CIRCUIT



\*  $I_1 = 10\text{mA}$  AT  $V_+ = 1.8\text{V}$

FIGURE 4.  $r_{ON}$  TEST CIRCUIT

Test Circuits and Waveforms (Continued)

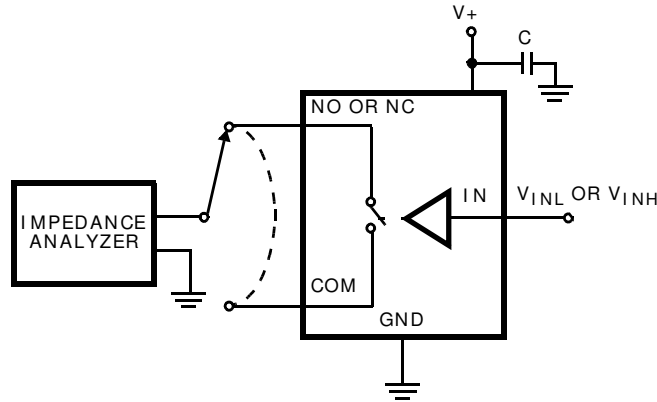

FIGURE 5. CAPACITANCE TEST CIRCUIT

Detailed Description

The ISL54504 and ISL54505 are bidirectional, single pole/single throw (SPST) analog switches. They offer precise switching capability from a single 1.8V to 5.5V supply with low ON-resistance ( $2.5\Omega$ ) and high speed operation ( $t_{ON} = 25\text{ns}$ ,  $t_{OFF} = 15\text{ns}$ ). The devices are especially well suited for portable battery powered equipment due to their low operating supply voltage (1.8V), low power consumption ( $0.15\mu\text{W}$ ), low leakage currents (300nA max) and tiny  $\mu\text{TDFN}$  and SOT-23 packages.

The ISL54504 is a single normally open (NO) SPST analog switch. The ISL54505 is a single normally closed (NC) SPST analog switch.

External V+ Series Resistor

For improved ESD and latch-up immunity, Intersil recommends adding a  $100\Omega$  resistor in series with the V+ power supply pin of the ISL54504, ISL54505 IC (see Figure 6).

During an overvoltage transient event (such as occurs during system level IEC 61000 ESD testing), substrate currents can be generated in the IC that can trigger parasitic SCR structures to turn ON, creating a low impedance path from the V+ power supply to ground. This will result in a significant amount of current flow in the IC, which can potentially create a latch-up state or permanently damage the IC. The external V+ resistor limits the current during this over-stress situation and has been found to prevent latch-up or destructive damage for many overvoltage transient events.

Under normal operation the sub-microamp  $I_{DD}$  current of the IC produces an insignificant voltage drop across the  $100\Omega$  series resistor resulting in no impact to switch operation or performance.

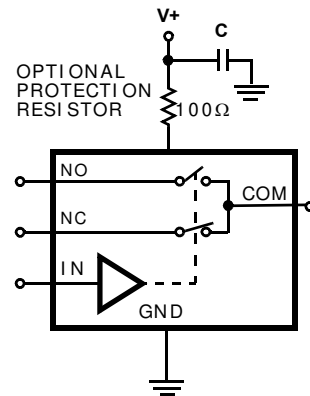

FIGURE 6. V+ SERIES RESISTOR FOR ENHANCED ESD AND LATCH-UP IMMUNITY

Supply Sequencing And Overvoltage Protection

With any CMOS device, proper power supply sequencing is required to protect the device from excessive input currents, which might permanently damage the IC. All I/O pins contain ESD protection diodes from the pin to V+ and to GND (see Figure 7). To prevent forward biasing these diodes, V+ must be applied before any input signals, and the input signal voltages must remain between V+ and GND.

If these conditions cannot be guaranteed then precautions must be implemented to prohibit the current and voltage at the logic pin and signal pins from exceeding the maximum ratings of the switch. The following two methods can be used to provide additional protection to limit the current in the event that the voltage at a signal pin or logic pin goes below ground or above the V+ rail.

Logic inputs can easily be protected by adding a  $1\text{k}\Omega$  resistor in series with the input (see Figure 7). The resistor limits the input current below the threshold that produces permanent damage and the sub-

microamp input current produces an insignificant voltage drop during normal operation.

This method is not acceptable for the signal path inputs. Adding a series resistor to the switch input defeats the purpose of using a low  $r_{ON}$  switch. Connecting Schottky diodes to the signal pins (as shown in Figure 7) will shunt the fault current to the supply or to ground, thereby protecting the switch. These Schottky diodes must be sized to handle the expected fault current.

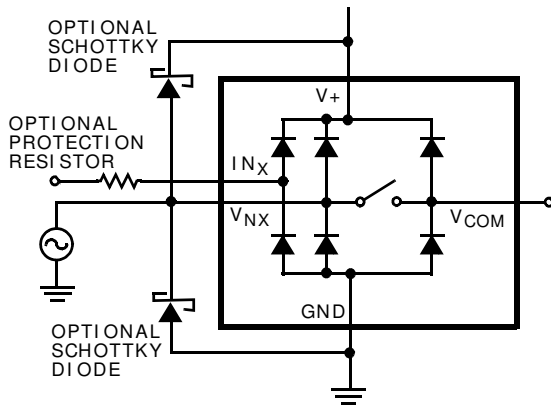

FIGURE 7. OVERVOLTAGE PROTECTION

### Power-Supply Considerations

The ISL54504, ISL54505 construction is typical of most single supply CMOS analog switches in that they have two supply pins:  $V+$  and  $GND$ .  $V+$  and  $GND$  drive the internal CMOS switches and set their analog voltage limits. Unlike switches with a 4V maximum supply voltage, the ISL54504, ISL54505 5.5V maximum supply voltage provides plenty of room for the 10% tolerance of 3.6V supplies, as well as room for overshoot and noise spikes.

The minimum recommended supply voltage is 1.8V but the part will operate with a supply below 1.8V. It is important to note that the input signal range, switching times, and ON-resistance degrade at lower supply voltages. Refer to the “Electrical Specifications” tables starting on page 3 and the “Typical Performance Curves” starting on page 9 for details.

$V+$  and  $GND$  also power the internal logic and level shifter. The level shifter converts the input logic levels to switched  $V+$  and  $GND$  signals to drive the analog switch gate terminals.

This family of switches cannot be operated with bipolar supplies because the input switching point becomes negative in this configuration.

### Logic-Level Thresholds

This switch family is 1.8V CMOS compatible (0.5V and 1.4V) over a supply range of 2V to 3.6V (see Figure 14). At 3.6V the  $V_{IH}$  level is about 0.95V. This is still below the 1.8V CMOS guaranteed high output minimum level of 1.4V, but noise margin is reduced.

The digital input stages draw supply current whenever the digital input voltage is not at one of the supply rails. Driving the digital input signals from  $GND$  to  $V+$  with a fast transition time minimizes power dissipation.

### High-Frequency Performance

In 50Ω systems, the ISL54504/ISL54505 has a -3dB bandwidth of 250MHz (see Figure 15). The frequency response is very consistent over a wide  $V+$  range and for varying analog signal levels.

An OFF switch behaves like a capacitor and passes higher frequencies with less attenuation, resulting in signal feedthrough from a switch’s input to output. Off isolation is the resistance of this signal feedthrough. Figure 16 details the high off isolation provided by the ISL54504, ISL54505. At 1MHz, off isolation is about 70dB in 50Ω systems, decreasing approximately 20dB per decade as frequency increases. Higher load impedances decrease off isolation due to the voltage divider action of the switch OFF impedance and the load impedance.

### Leakage Considerations

Reverse ESD protection diodes are internally connected between each analog-signal pin and both  $V+$  and  $GND$ . One of these diodes conducts if any analog signal exceeds  $V+$  or  $GND$ .

Virtually all the analog leakage current comes from the ESD diodes to  $V+$  or  $GND$ . Although the ESD diodes on a given signal pin are identical and therefore fairly well balanced, they are reverse biased differently. Each is biased by either  $V+$  or  $GND$  and the analog signal. This means their leakages will vary as the signal varies. The difference in the two diode leakages to the  $V+$  and  $GND$  pins constitutes the analog-signal-path leakage current. All analog leakage current flows between each pin and one of the supply terminals, not to the other switch terminal. This is why both sides of a given switch can show leakage currents of the same or opposite polarity. There is no connection between the analog signal paths and  $V+$  or  $GND$ .



Typical Performance Curves  $T_A = +25^\circ\text{C}$ , Unless Otherwise Specified.

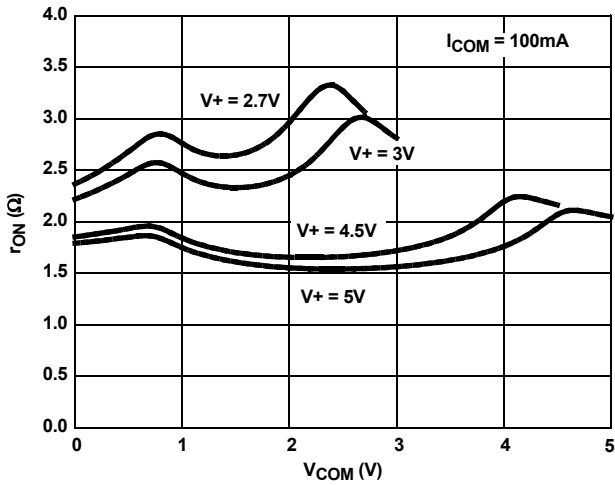

FIGURE 8. ON-RESISTANCE vs SUPPLY VOLTAGE vs SWITCH VOLTAGE

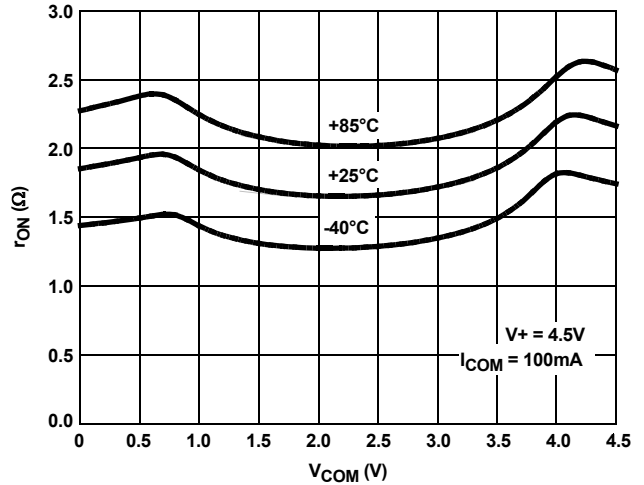

FIGURE 9. ON-RESISTANCE vs SWITCH VOLTAGE

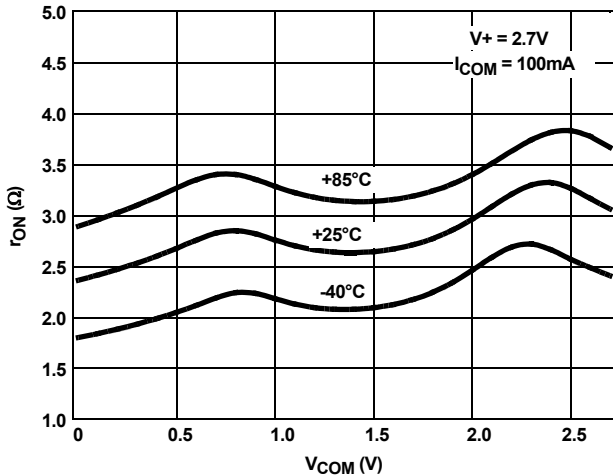

FIGURE 10. ON-RESISTANCE vs SWITCH VOLTAGE

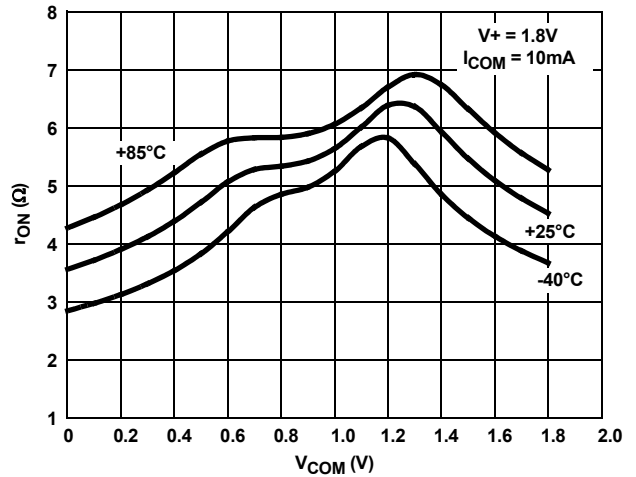

FIGURE 11. ON-RESISTANCE vs SWITCH VOLTAGE

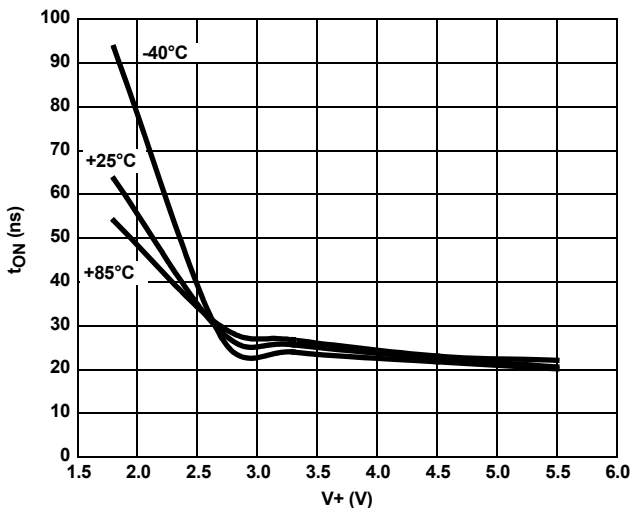

FIGURE 12. TURN-ON TIME vs SUPPLY VOLTAGE

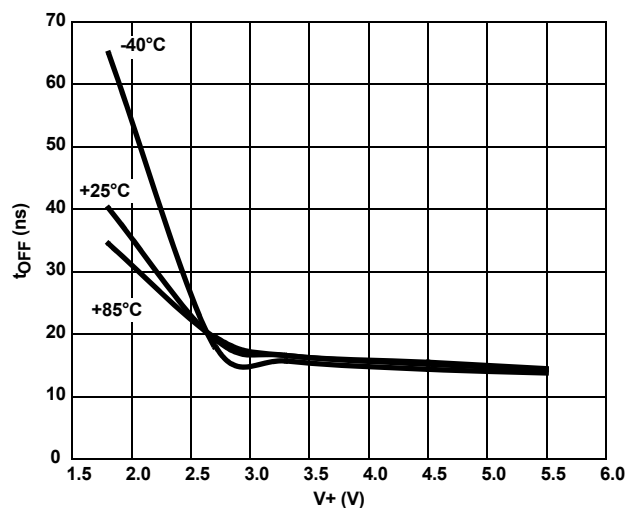

FIGURE 13. TURN-OFF TIME vs SUPPLY VOLTAGE

Typical Performance Curves  $T_A = +25^\circ\text{C}$ , Unless Otherwise Specified. (Continued)

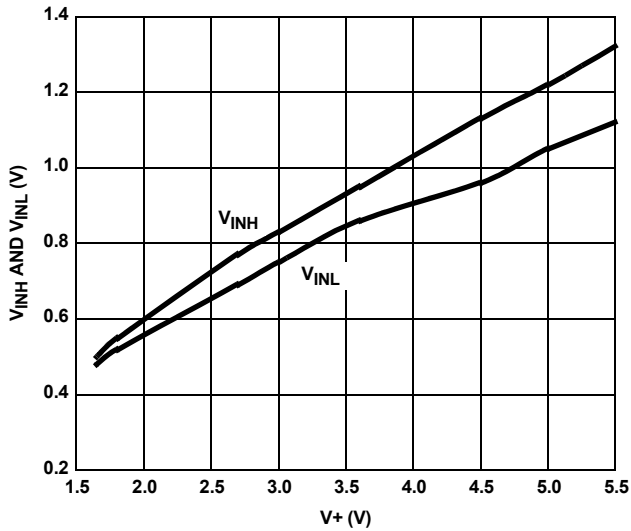

FIGURE 14. DIGITAL SWITCHING POINT vs SUPPLY VOLTAGE

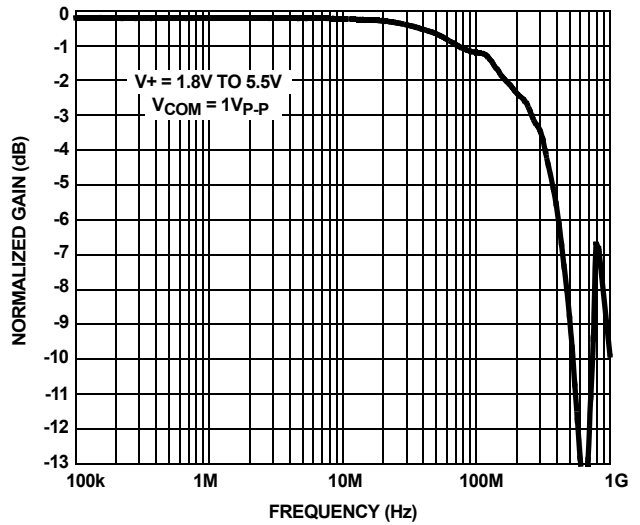

FIGURE 15. FREQUENCY RESPONSE

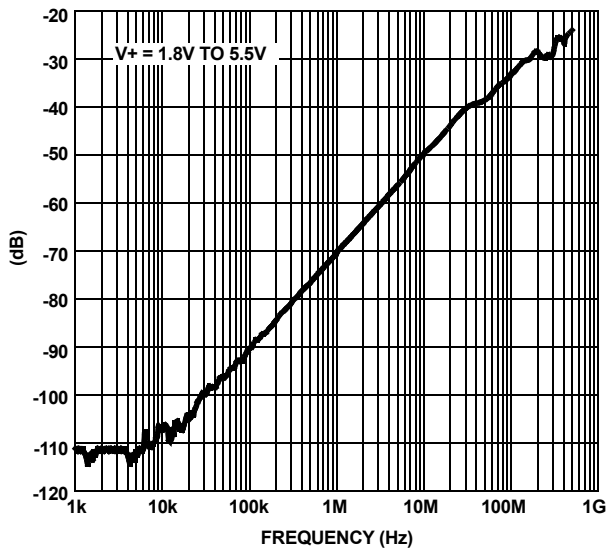

FIGURE 16. OFF ISOLATION

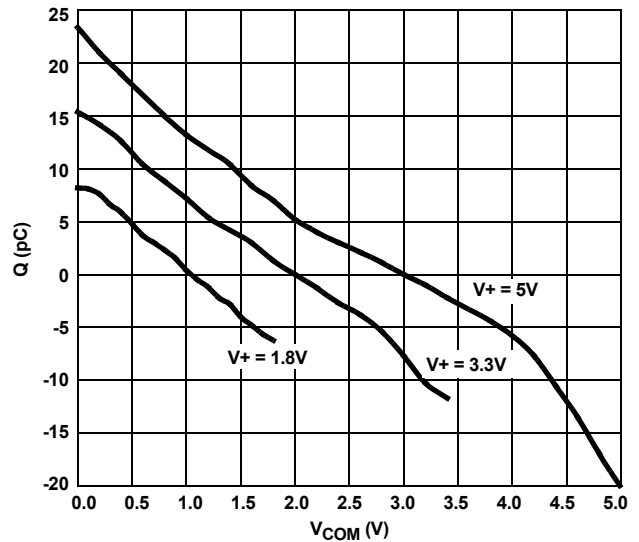

FIGURE 17. CHARGE INJECTION vs SWITCH VOLTAGE

## Die Characteristics

SUBSTRATE POTENTIAL (POWERED UP):

GND

TRANSISTOR COUNT:

PROCESS:

Submicron CMOS

**Ultra Thin Dual Flat No-Lead Plastic Package (UTDFN)**

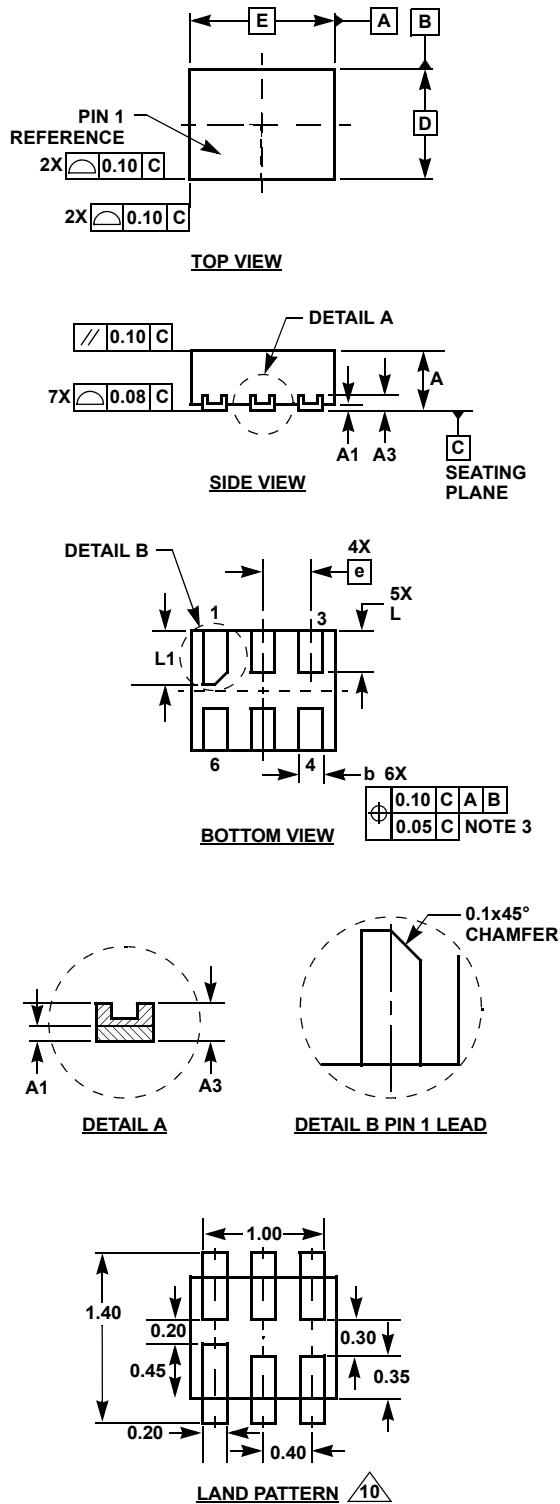

**L6.1.2x1.0A**

**6 LEAD ULTRA THIN DUAL FLAT NO-LEAD PLASTIC PACKAGE**

SYMBOL	MILLIMETERS			NOTES
	MIN	NOMINAL	MAX	
A	0.45	0.50	0.55	-
A1	-	-	0.05	-
A3	0.127 REF			-
b	0.15	0.20	0.25	5
D	0.95	1.00	1.05	-
E	1.15	1.20	1.25	-
e	0.40 BSC			-
L	0.30	0.35	0.40	-
L1	0.40	0.45	0.50	-
N	6			2
Ne	3			3
θ	0	-	12	4

Rev. 2 8/06

**NOTES:**

1. Dimensioning and tolerancing conform to ASME Y14.5-1994.
2. N is the number of terminals.
3. Ne refers to the number of terminals on E side.
4. All dimensions are in millimeters. Angles are in degrees.
5. Dimension b applies to the metallized terminal and is measured between 0.15mm and 0.30mm from the terminal tip.
6. The configuration of the pin #1 identifier is optional, but must be located within the zone indicated. The pin #1 identifier may be either a mold or mark feature.
7. Maximum package warpage is 0.05mm.
8. Maximum allowable burrs is 0.076mm in all directions.
9. JEDEC Reference MO-255.
10. For additional information, to assist with the PCB Land Pattern Design effort, see Intersil Technical Brief TB389.

**SOT-23 Package Family**

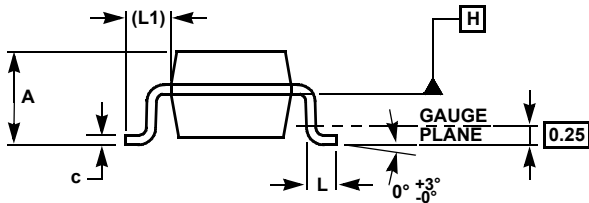
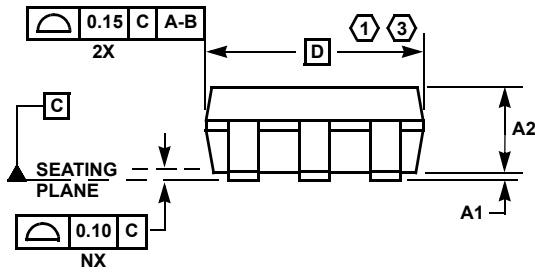
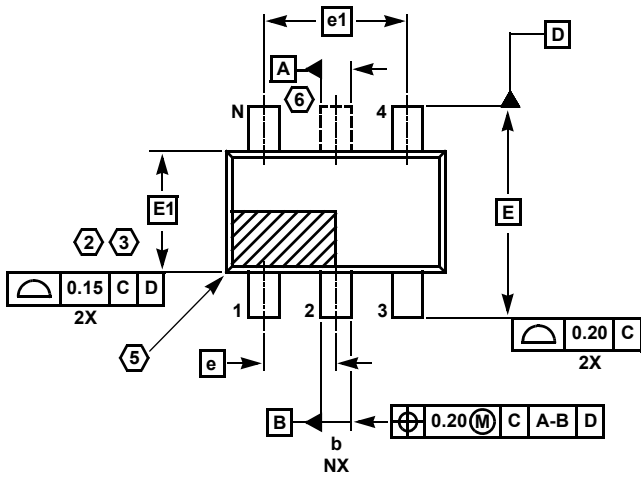

**MDP0038**

**SOT-23 PACKAGE FAMILY**

SYMBOL	MILLIMETERS		TOLERANCE
	SOT23-5	SOT23-6	
A	1.45	1.45	MAX
A1	0.10	0.10	±0.05
A2	1.14	1.14	±0.15
b	0.40	0.40	±0.05
c	0.14	0.14	±0.06
D	2.90	2.90	Basic
E	2.80	2.80	Basic
E1	1.60	1.60	Basic
e	0.95	0.95	Basic
e1	1.90	1.90	Basic
L	0.45	0.45	±0.10
L1	0.60	0.60	Reference
N	5	6	Reference

Rev. F 2/07

**NOTES:**

1. Plastic or metal protrusions of 0.25mm maximum per side are not included.
2. Plastic interlead protrusions of 0.25mm maximum per side are not included.
3. This dimension is measured at Datum Plane "H".
4. Dimensioning and tolerancing per ASME Y14.5M-1994.
5. Index area - Pin #1 I.D. will be located within the indicated zone (SOT23-6 only).
6. SOT23-5 version has no center lead (shown as a dashed line).

For additional products, see [www.intersil.com/product\\_tree](http://www.intersil.com/product_tree)

Intersil products are manufactured, assembled and tested utilizing ISO9001 quality systems as noted in the quality certifications found at [www.intersil.com/design/quality](http://www.intersil.com/design/quality)

*Intersil products are sold by description only. Intersil Corporation reserves the right to make changes in circuit design, software and/or specifications at any time without notice. Accordingly, the reader is cautioned to verify that data sheets are current before placing orders. Information furnished by Intersil is believed to be accurate and reliable. However, no responsibility is assumed by Intersil or its subsidiaries for its use; nor for any infringements of patents or other rights of third parties which may result from its use. No license is granted by implication or otherwise under any patent or patent rights of Intersil or its subsidiaries.*

For information regarding Intersil Corporation and its products, see [www.intersil.com](http://www.intersil.com)