

ADC0819 8-Bit Serial I/O A/D Converter with 19-Channel Multiplexer

General Description

The ADC0819 is an 8-bit successive approximation A/D converter with simultaneous serial I/O. The serial input controls an analog multiplexer which selects from 19 input channels or an internal half scale test voltage.

An input sample-and-hold is implemented by a capacitive reference ladder and sampled data comparator. This allows the input signal to vary during the conversion cycle.

Separate serial I/O and conversion clock inputs are provided to facilitate the interface to various microprocessors.

Features

- Separate asynchronous converter clock and serial data I/O clock.
- 19-Channel multiplexer with 5-bit serial address logic.
- Built-in sample and hold function.

- Ratiometric or absolute voltage referencing.
- No zero or full-scale adjust required.
- Internally addressable test voltage.
- 0V to 5V input range with single 5V power supply.
- TTL/MOS input/output compatible.
- 28-pin molded chip carrier or 28-pin molded DIP

Key Specifications

- Resolution 8-Bits
- Total unadjusted error $\pm 1/2$ LSB and ± 1 LSB
- Single supply 5V_{DC}
- Low Power 15 mW
- Conversion Time 16 μ s

Connection Diagrams Functional Diagram

Molded Chip Carrier (PCC) Package

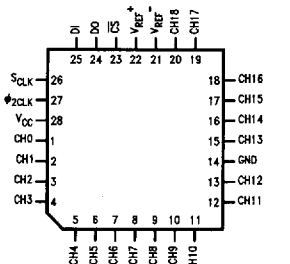

Top View

Order Number ADC0819BCV, CCV
See NS Package Number V28A

Dual-In-Line Package

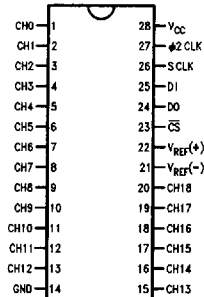

Top View

Order Number ADC0819BCN, CIN
See NS Package Number N28B

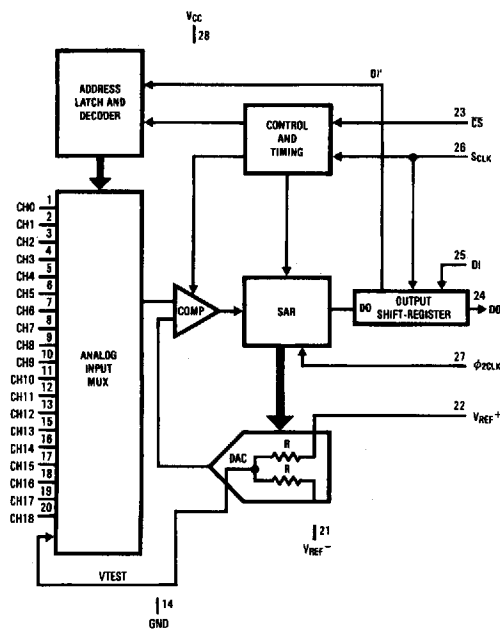

TL/H/9287-2

Absolute Maximum Ratings (Notes 1 & 2)

If Military/Aerospace specified devices are required, please contact the National Semiconductor Sales Office/Distributors for availability and specifications.

| | |
|--|---------------------------------|
| Supply Voltage (V _{CC}) | 6.5V |
| Voltage | |
| Inputs and Outputs | -0.3V to V _{CC} + 0.3V |
| Input Current Per Pin (Note 3) | ±5mA |
| Total Package Input Current (Note 3) | ±20mA |
| Storage Temperature | -65°C to +150°C |
| Package Dissipation at T _A = 25°C | 875 mW |

| | |
|---------------------------------------|-------|
| Lead Temperature (Soldering, 10 sec.) | 260°C |
| Dual-In-Line Package (Plastic) | |
| Surface Mount Package | |
| Vapor Phase (60 sec.) | 215°C |
| Infrared (15 sec.) | 220°C |
| ESD Susceptibility (Note 11) | 2000V |

Operating Ratings (Notes 1 & 2)

| | |
|-----------------------------------|--|
| Supply Voltage (V _{CC}) | 4.5 V _{DC} to 6.0 V _{DC} |
| Temperature Range | T _{MIN} ≤ T _A ≤ T _{MAX} |
| ADC0819BCV, ADC0819CCV | -40°C ≤ T _A ≤ +85°C |
| ADC0819BCN | 0°C ≤ T _A ≤ +70°C |
| ADC0819CIN | -40°C ≤ T _A ≤ +85°C |

Electrical Characteristics

The following specifications apply for V_{CC} = 5V, V_{REF} = 5V, φ₂ CLK = 2.097 MHz unless otherwise specified. **Boldface limits apply from T_{MIN} to T_{MAX}**; all other limits T_A = T_J = 25°C.

| Parameter | Conditions | Typical (Note 6) | Tested Limit (Note 7) | Design Limit (Note 8) | Units |
|--|--|------------------|------------------------|------------------------------|---------------------|
| CONVERTER AND MULTIPLEXER CHARACTERISTICS | | | | | |
| Maximum Total Unadjusted Error ADC0819BCV, BCN ADC0819CCV, CIN | V _{REF} = 5.00 V _{DC} (Note 4) | | ±½ ±1 | ±½ ±1 | LSB LSB |
| Minimum Reference Input Resistance | | 8 | | 5 | kΩ |
| Maximum Reference Input Resistance | | 8 | 11 | 11 | kΩ |
| Maximum Analog Input Range | (Note 5) | | V _{CC} + 0.05 | V_{CC} + 0.05 | V |
| Minimum Analog Input Range | | | GND - 0.05 | GND - 0.05 | V |
| On Channel Leakage Current | (Note 9) On Channel = 5V Off Channel = 0V | | 400 | 1000 | nA |
| | On Channel = 0V Off Channel = 5V (Note 9) | | -400 | -1000 | nA |
| Off Channel Leakage Current | (Note 9) On Channel = 5V Off Channel = 0V | | -400 | -1000 | nA |
| | On Channel = 0V Off Channel = 5V (Note 9) | | 400 | 1000 | nA |
| Minimum V _{TEST} Internal Test Voltage | V _{REF} = V _{CC} , CH 19 Selected | | 125 | 125 | (Note 10) Counts |
| Maximum V _{TEST} Internal Test Voltage | V _{REF} = V _{CC} , CH 19 Selected | | 130 | 130 | (Note 10) Counts |
| DIGITAL AND DC CHARACTERISTICS | | | | | |
| V _{IN(1)} , Logical "1" Input Voltage (Min) | V _{CC} = 5.25V | | 2.0 | 2.0 | V |
| V _{IN(0)} , Logical "0" Input Voltage (Max) | V _{CC} = 4.75V | | 0.8 | 0.8 | V |
| I _{IN(1)} , Logical "1" Input Current (Max) | V _{IN} = 5.0V | 0.005 | 2.5 | 2.5 | μA |
| I _{IN(0)} , Logical "0" Input Current (Max) | V _{IN} = 0V | -0.005 | -2.5 | -2.5 | μA |

Electrical Characteristics (Continued)

The following specifications apply for $V_{CC} = 5V$, $V_{REF} = 5V$, $\phi_2 CLK = 2.097 MHz$ unless otherwise specified. **Boldface limits apply from T_{MIN} to T_{MAX}** ; all other limits $T_A = T_J = 25^\circ C$.

| Parameter | Conditions | Typical (Note 6) | Tested Limit (Note 7) | Design Limit (Note 8) | Units |
|--|---|---------------------|-----------------------------|-----------------------------|---------|
| DIGITAL AND DC CHARACTERISTICS (Continued) | | | | | |
| $V_{OUT(1)}$, Logical "1" Output Voltage (Min) | $V_{CC} = 4.75V$ $I_{OUT} = -360 \mu A$ $I_{OUT} = -10 \mu A$ | | 2.4 | 2.4 | V |
| | | | 4.5 | 4.5 | V |
| $V_{OUT(0)}$, Logical "0" Output Voltage (Max) | $V_{CC} = 5.25V$ $I_{OUT} = 1.6 mA$ | | 0.4 | 0.4 | V |
| I_{OUT} , TRI-STATE Output Current (Max) | $V_{OUT} = 0V$ $V_{OUT} = 5V$ | -0.01 | -3 | -3 | μA |
| | | 0.01 | 3 | 3 | μA |
| I_{SOURCE} , Output Source Current (Min) | $V_{OUT} = 0V$ | -14 | -6.5 | -6.5 | mA |
| I_{SINK} , Output Sink Current (Min) | $V_{OUT} = V_{CC}$ | 16 | 8.0 | 8.0 | mA |
| I_{CC} , Supply Current (Max) | $\overline{CS} = 1$, V_{REF} Open | 1 | 2.5 | 2.5 | mA |
| I_{REF} (Max) | $V_{REF} = 5V$ | 0.7 | 1 | 1 | mA |

AC CHARACTERISTICS

| Parameter | Conditions | Typical (Note 6) | Tested Limit (Note 7) | Design Limit (Note 8) | Units |
|--|---------------------------------|---|-----------------------------|--------------------------------------|-----------------|
| $\phi_2 CLK$, ϕ_2 Clock Frequency | MIN | 0.70 | | 1.0 | MHz |
| | MAX | 4.0 | 2.0 | 2.1 | |
| S_{CLK} , Serial Data Clock Frequency | MIN | | | 5.0 | KHz |
| | MAX | 1000 | 525 | 525 | |
| T_C , Conversion Process Time | MIN | Not Including MUX Addressing and Analog Input Sampling Times | 26 | 26 | ϕ_2 cycles |
| | MAX | | 32 | 32 | |
| t_{ACC} , Access Time Delay From \overline{CS} Falling Edge to DO Data Valid | MIN | | | 1 | ϕ_2 cycles |
| | MAX | | | 3 | |
| t_{SET-UP} , Minimum Set-up Time of \overline{CS} Falling Edge to S_{CLK} Rising Edge | | | | $4/\phi_2 CLK + \frac{1}{2 S_{CLK}}$ | sec |
| t_{HCS} , \overline{CS} Hold Time After the Falling Edge of S_{CLK} | | | | 0 | ns |
| t_{CS} , Total \overline{CS} Low Time | MIN | | | $t_{set-up} + 8/S_{CLK}$ | sec |
| | MAX | | | $t_{CS(min)} + 26/\phi_2 CLK$ | sec |
| t_{HDI} , Minimum DI Hold Time from S_{CLK} Rising Edge | | | 0 | 0 | ns |
| t_{HDO} , Minimum DO Hold Time from S_{CLK} Falling Edge | $R_L = 30k$, $C_L = 100 pF$ | | | 10 | ns |
| t_{SDI} , Minimum DI Set-up Time to S_{CLK} Rising Edge | | 200 | | 400 | ns |
| t_{DDO} , Maximum Delay From S_{CLK} Falling Edge to DO Data Valid | $R_L = 30k$, $C_L = 100 pF$ | 180 | 200 | 250 | ns |
| t_{TRI} , Maximum DO Hold Time, (\overline{CS} Rising edge to DO TRI-STATE) | $R_L = 3k$, $C_L = 100 pF$ | 90 | 150 | 150 | ns |

Electrical Characteristics The following specifications apply for $V_{CC} = 5V$, $t_r = t_f = 20\text{ ns}$, $V_{REF} = 5V$, unless otherwise specified. **Boldface limits apply from T_{MIN} to T_{MAX}** ; all other limits $T_A = T_J = 25^\circ C$.

| Parameter | Conditions | Typical (Note 6) | Tested Limit (Note 7) | Design Limit (Note 8) | Units | |
|---------------------------------------|--|-----------------------------|-----------------------|--|------------|----|
| AC CHARACTERISTICS (Continued) | | | | | | |
| t_{CA} , Analog Sampling Time | After Address Is Latched $\overline{CS} = \text{Low}$ | | | $3/S_{CLK} + 1\ \mu s$ | sec | |
| t_{rDO} , Maximum DO Rise Time | $R_L = 30\text{ k}\Omega$, $C_L = 100\text{ pf}$ | "TRI-STATE" to "HIGH" State | 75 | 150 | 150 | ns |
| | | "LOW" to "HIGH" State | 150 | 300 | 300 | |
| t_{fDO} , Maximum DO Fall Time | $R_L = 30\text{ k}\Omega$, $C_L = 100\text{ pf}$ | "TRI-STATE" to "LOW" State | 75 | 150 | 150 | ns |
| | | "HIGH" to "LOW" State | 150 | 300 | 300 | |
| C_{IN} , Maximum Input Capacitance | Analog Inputs, AN0-AN10 and V_{REF} | 11 | | 55 | pF | |
| | All Others | 5 | | 15 | | |

Note 1: Absolute Maximum Ratings indicate limits beyond which damage to the device may occur. DC and AC electrical specifications do not apply when operating the device beyond its specified operating conditions.

Note 2: All voltages are measured with respect to ground.

Note 3: Under over voltage conditions ($V_{IN} < 0V$ and $V_{IN} > V_{CC}$) the maximum input current at any one pin is $\pm 5\text{ mA}$. If the voltage at more than one pin exceeds $V_{CC} + .3V$ the total package current must be limited to 20 mA. For example the maximum number of pins that can be over driven at the maximum current level of $\pm 5\text{ mA}$ is four.

Note 4: Total unadjusted error includes offset, full-scale, linearity, multiplexer, and hold step errors.

Note 5: Two on-chip diodes are tied to each analog input, which will forward-conduct for analog input voltages one diode drop below ground or one diode drop greater than V_{CC} supply. Be careful during testing at low V_{CC} levels (4.5V), as high level analog inputs (5V) can cause this input diode to conduct, especially at elevated temperatures, and cause errors for analog inputs near full-scale. The spec allows 50 mV forward bias of either diode. This means that as long as the analog V_{IN} does not exceed the supply voltage by more than 50 mV, the output code will be correct. To achieve an absolute 0 V_{DC} to 5 V_{DC} input voltage range will therefore require a minimum supply voltage of 4.950 V_{DC} over temperature variations, initial tolerance and loading.

Note 6: Typicals are at 25°C and represent most likely parametric norm.

Note 7: Tested Limits are guaranteed to National's AOQL (Average Outgoing Quality Level).

Note 8: Design Limits are guaranteed, but not 100% production tested. These limits are not used to calculate outgoing quality levels.

Note 9: Channel leakage current is measured after the channel selection.

Note 10: 1 count = $V_{REF}/256$.

Note 11: Human body model; 100 pF discharged through a 1.5 k Ω resistor.

Test Circuits

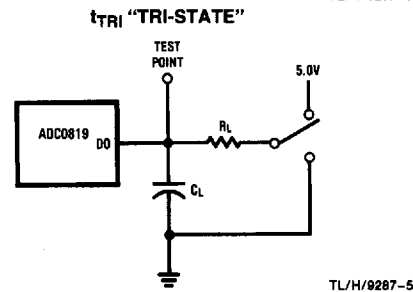
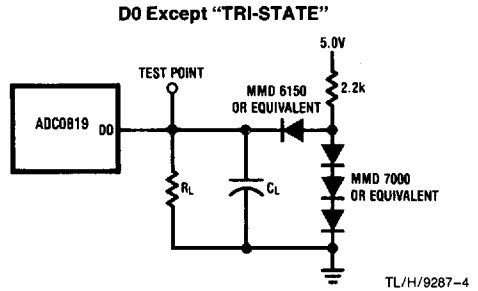
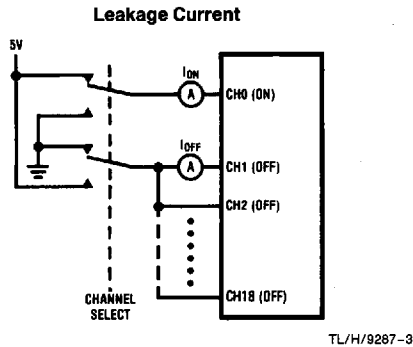

Timing Diagrams

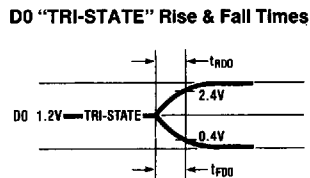

Timing Diagrams (Continued)

D0 Low to High State

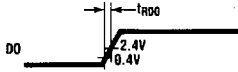

TL/H/9287-7

D0 High to Low State

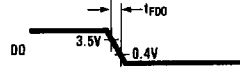

TL/H/9287-8

Data Input and Output Timing

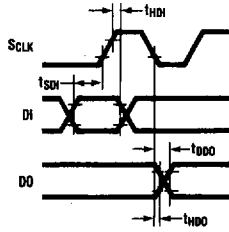

TL/H/9287-9

Timing with a continuous SCLK

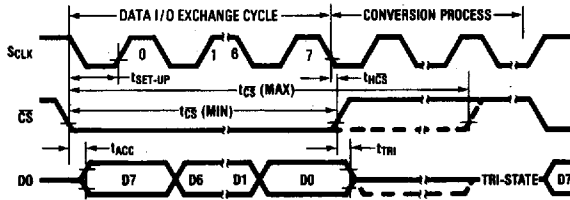

TL/H/9287-10

*Strobing CS High and Low will abort the present conversion and initiate a new serial I/O exchange.

Timing with a gated SCLK and CS Continuously Low

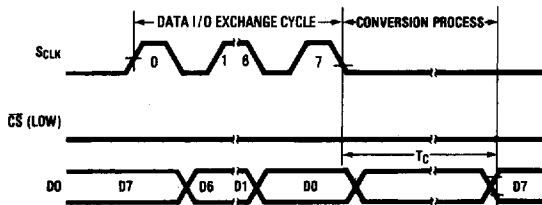

TL/H/9287-11

Using CS To TRI-STATE D0

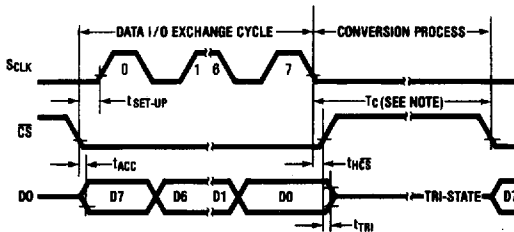

TL/H/9287-12

Note: Strobing CS Low during this time interval will abort the conversion in process.

Timing Diagrams (Continued)

\overline{CS} High During Conversion

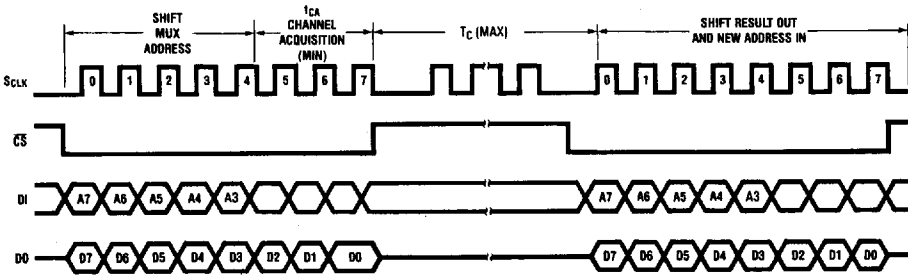

TL/H/9287-13

\overline{CS} Low During Conversion

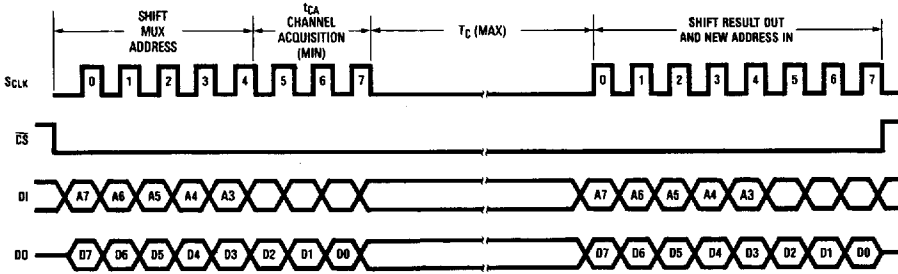

TL/H/9287-14

Channel Addressing Table

TABLE I. ADC 0819 Channel Addressing

| MUX ADDRESS | | | | | | | | ANALOG CHANNEL SELECTED |
|----------------|----------------|----------------|----------------|----------------|----------------|----------------|----------------|-------------------------|
| A ₇ | A ₆ | A ₅ | A ₄ | A ₃ | A ₂ | A ₁ | A ₀ | |
| 0 | 0 | 0 | 0 | 0 | X | X | X | CH0 |
| 0 | 0 | 0 | 0 | 1 | X | X | X | CH1 |
| 0 | 0 | 0 | 1 | 0 | X | X | X | CH2 |
| 0 | 0 | 0 | 1 | 1 | X | X | X | CH3 |
| 0 | 0 | 1 | 0 | 0 | X | X | X | CH4 |
| 0 | 0 | 1 | 0 | 1 | X | X | X | CH5 |
| 0 | 0 | 1 | 1 | 0 | X | X | X | CH6 |
| 0 | 0 | 1 | 1 | 1 | X | X | X | CH7 |
| 0 | 1 | 0 | 0 | 0 | X | X | X | CH8 |
| 0 | 1 | 0 | 0 | 1 | X | X | X | CH9 |
| 0 | 1 | 0 | 1 | 0 | X | X | X | CH10 |
| 0 | 1 | 0 | 1 | 1 | X | X | X | CH11 |
| 0 | 1 | 1 | 0 | 0 | X | X | X | CH12 |
| 0 | 1 | 1 | 0 | 1 | X | X | X | CH13 |
| 0 | 1 | 1 | 1 | 0 | X | X | X | CH14 |
| 0 | 1 | 1 | 1 | 1 | X | X | X | CH15 |
| 1 | 0 | 0 | 0 | 0 | X | X | X | CH16 |
| 1 | 0 | 0 | 0 | 1 | X | X | X | CH17 |
| 1 | 0 | 0 | 1 | 0 | X | X | X | CH18 |
| 1 | 0 | 0 | 1 | 1 | X | X | X | V _{TEST} |
| 1 | 0 | 1 | 0 | 0 | X | X | X | No Channel Select |
| 1 | 0 | 1 | 0 | 1 | X | X | X | No Channel Select |
| 1 | 0 | 1 | 1 | 0 | X | X | X | No Channel Select |
| 1 | 0 | 1 | 1 | 1 | X | X | X | No Channel Select |
| 1 | 1 | X | X | X | X | X | X | Logic Test Mode* |

*Analog channel inputs CH0 thru CH4 are logic outputs

Functional Description

1.0 DIGITAL INTERFACE

The ADC0819 uses five input/output pins to implement the serial interface. Taking chip select (\overline{CS}) low enables the I/O data lines (DO and DI) and the serial clock input (S_{CLK}). The result of the last conversion is transmitted by the A/D on the DO line, while simultaneously the DI line receives the address data that selects the mux channel for the next conversion. The mux address is shifted in on the rising edge of S_{CLK} and the conversion data is shifted out on the falling edge. It takes eight S_{CLK} cycles to complete the serial I/O. A second clock (ϕ_2) controls the SAR during the conversion process and must be continuously enabled.

1.1 CONTINUOUS S_{CLK}

With a continuous S_{CLK} input \overline{CS} must be used to synchronize the serial data exchange (see Figure 1). The ADC0819 recognizes a valid \overline{CS} one to three ϕ_2 clock periods after the actual falling edge of \overline{CS} . This is implemented to ensure noise immunity of the \overline{CS} signal. Any spikes on \overline{CS} less than one ϕ_2 clock period will be ignored. \overline{CS} must remain low during the complete I/O exchange which takes eight S_{CLK} cycles. Although \overline{CS} is not immediately acknowledged for the purpose of starting a new conversion, the falling edge of \overline{CS} immediately enables DO to output the MSB (D7) of the previous conversion.

The first S_{CLK} rising edge will be acknowledged after a set-up time (t_{set-up}) has elapsed from the falling edge of \overline{CS} . This and the following seven S_{CLK} rising edges will shift in the channel address for the analog multiplexer. Since there are 19 channels only five address bits are utilized. The first five S_{CLK} cycles clock in the mux address, during the next three S_{CLK} cycles the analog input is selected and sampled. During

this mux address/sample cycle, data from the last conversion is also clocked out on DO. Since D7 was clocked out on the falling edge of \overline{CS} only data bits D6–D0 remain to be received. The following seven falling edges of S_{CLK} shift out this data on DO.

The 8th S_{CLK} falling edge initiates the beginning of the A/D's actual conversion process which takes between 26 and 32 ϕ_2 cycles (T_C). During this time \overline{CS} can go high to TRI-STATE DO and disable the S_{CLK} input or it can remain low. If \overline{CS} is held low a new I/O exchange will not start until the conversion sequence has been completed, however once the conversion ends serial I/O will immediately begin. Since there is an ambiguity in the conversion time (T_C) synchronizing the data exchange is impossible. Therefore \overline{CS} should go high before the 26th ϕ_2 clock has elapsed and return low after the 32nd ϕ_2 to synchronize serial communication.

A conversion or I/O operation can be aborted at any time by strobing \overline{CS} . If \overline{CS} is high or low less than one ϕ_2 clock it will be ignored by the A/D. If the \overline{CS} is strobed high or low between 1 to 3 ϕ_2 clocks the A/D may or may not respond. Therefore \overline{CS} must be strobed high or low greater than 3 ϕ_2 clocks to ensure recognition. If a conversion or I/O exchange is aborted while in process the consequent data output will be erroneous until a complete conversion sequence has been implemented.

1.2 DISCONTINUOUS S_{CLK}

Another way to accomplish synchronous serial communication is to tie \overline{CS} low continuously and disable S_{CLK} after its 8th falling edge (see Figure 2). S_{CLK} must remain low for

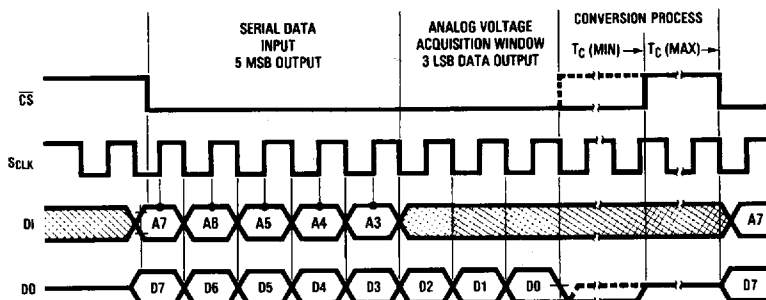

FIGURE 1

TL/H/9287-16

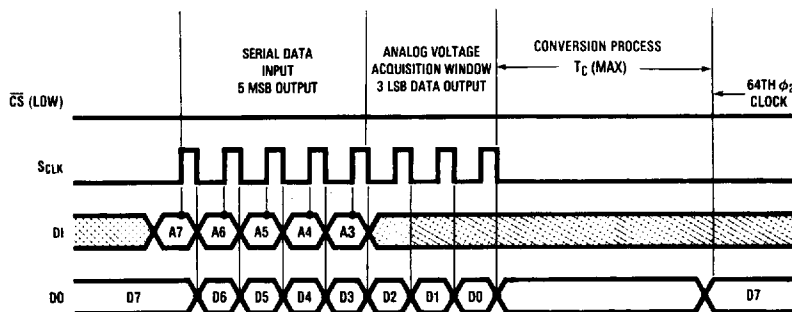

FIGURE 2

TL/H/9287-17

Functional Description (Continued)

at least $32 \phi_2$ clocks to ensure that the A/D has completed its conversion. If S_{CLK} is enabled sooner, synchronizing to the data output on DO is not possible since an end of conversion signal from the A/D is not available and the actual conversion time is not known. With \overline{CS} low during the conversion time ($32 \phi_2$ max) DO will go high or low after the eighth falling edge of S_{CLK} until the conversion is completed. Once the conversion is through DO will transmit the MSB. The rest of the data will be shifted out once S_{CLK} is enabled as discussed previously.

If \overline{CS} goes high during the conversion sequence DO is tri-stated, and the result is not affected so long as \overline{CS} remains high until the end of the conversion.

1.2 MULTIPLEXER ADDRESSING

The five bit mux address is shifted, MSB first, into DI . Input data corresponds to the channel selected as shown in table 1. Care should be taken not to send an address greater than or equal to twenty four (11XXX) as this puts the A/D in a digital testing mode. In this mode the analog inputs $CH0$ thru $CH4$ become digital outputs, for our use in production testing.

2.0 ANALOG INPUT

2.1 THE INPUT SAMPLE AND HOLD

The ADC0819's sample/hold capacitor is implemented in its capacitive ladder structure. After the channel address is received, the ladder is switched to sample the proper analog input. This sampling mode is maintained for $1 \mu\text{sec}$ after the

eighth S_{CLK} falling edge. The hold mode is initiated with the start of the conversion process. An acquisition window of $3t_{S_{CLK}} + 1 \mu\text{sec}$ is therefore available to allow the ladder capacitance to settle to the analog input voltage. Any change in the analog voltage before or after the acquisition window will not effect the A/D conversion result.

In the most simple case, the ladder's acquisition time is determined by the R_{on} ($3K$) of the multiplexer switches and the total ladder capacitance (90pf). These values yield an acquisition time of about $2 \mu\text{sec}$ for a full scale reading. Therefore the analog input must be stable for at least $2 \mu\text{sec}$ before and $1 \mu\text{sec}$ after the eighth S_{CLK} falling edge to ensure a proper conversion. External input source resistance and capacitance will lengthen the acquisition time and should be accounted for.

Other conventional sample and hold error specifications are included in the error and timing specs of the A/D. The hold step and gain error sample/hold specs are taken into account in the ADC0819's total unadjusted error, while the hold settling time is included in the A/D's max conversion time of $32 \phi_2$ clock periods. The hold droop rate can be thought of as being zero since an unlimited amount of time can pass between a conversion and the reading of data. However, once the data is read it is lost and another conversion is started.

Typical Applications

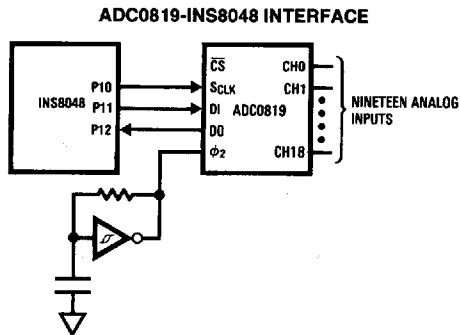

TL/H/9287-18

