

MQ-W SERIES

Related Information

- General terms and conditions..... F-7
- Sensor selection guide..... P.271~
- Glossary of terms..... P.1455~
- General precautions P.1458~



Sensing objects can be detected at a constant distance using the triple beam sensing method

Hardly affected by color

Adjustable range reflective type sensor can detect white or black object at the same distance. Therefore, the sensor can even detect individual objects that are mixed with black objects or objects of various colors that were hard for the diffuse reflective type sensor to detect.

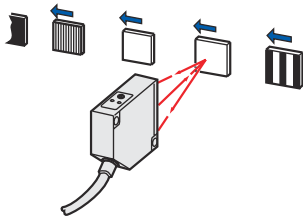

(However, when the background is specular, it may be necessary to change the angle of the sensor.)

Hardly affected by background

Adjustable range reflective type sensor does not detect objects beyond the set range. For this reason, malfunction does not occur even if there are moving machines or people passing by in the background.

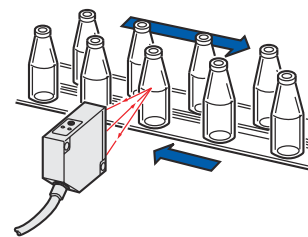

ENVIRONMENTAL RESISTANCE

Insusceptible to contamination on lens

Adjustable range reflective type sensor detects the distance by the angle, not by the light receiving intensity. Even if the lens surface is soiled by dust or any powdery material, there is little variation of sensing range. In addition, the sensor stably detects approaching objects at a fixed distance because the distance is sensed by the angle of received light.

MOUNTING / SIZE

Compact and slim size

A small size of W32 × H32 × D12.6 mm **W1.260 × H1.260 × D0.496 in** has been achieved for the 40 mm **1.575 in / 200 mm 7.874 in** sensing range type due to the built-in amplifier. In addition, you can mount the sensor both vertically and horizontally by diagonal mounting.

VARIETIES

Visible light type and low hysteresis type are available

Visible light type

Beam axis alignment can be performed by looking at the spot light.

Low hysteresis type

Hysteresis between the ON and OFF status has been reduced by half (compared to conventional model). Detection precision has been further improved!

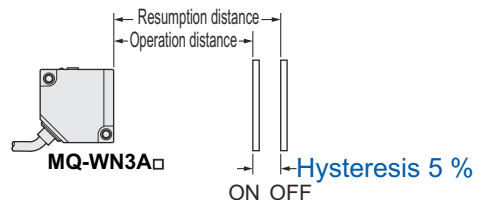

- FIBER SENSORS
- LASER SENSORS
- PHOTOELECTRIC SENSORS
- MICRO PHOTOELECTRIC SENSORS
- AREA SENSORS
- LIGHT CURTAINS / SAFETY COMPONENTS
- PRESSURE / FLOW SENSORS
- INDUCTIVE PROXIMITY SENSORS
- PARTICULAR USE SENSORS
- SENSOR OPTIONS
- SIMPLE WIRE-SAVING UNITS
- WIRE-SAVING SYSTEMS
- MEASUREMENT SENSORS
- STATIC ELECTRICITY PREVENTION DEVICES
- LASER MARKERS
- PLC
- HUMAN MACHINE INTERFACES
- ENERGY CONSUMPTION VISUALIZATION COMPONENTS
- FA COMPONENTS
- MACHINE VISION SYSTEMS
- UV CURING SYSTEMS

- Selection Guide
- Amplifier Built-in
- Power Supply Built-in
- Amplifier-separated

- CX-400
- CY-100
- EX-10
- EX-20
- EX-30
- EX-40
- CX-440
- EQ-30
- EQ-500
- MQ-W
- RX-LS200
- RX
- RT-610

APPLICATIONS

Object presence detection

The sensor detects objects that are being conveyed with almost no influence from background objects.

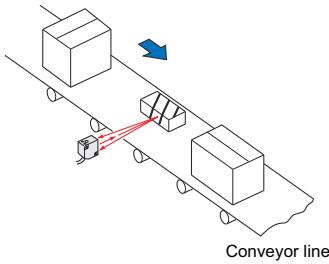

Black tire sensing

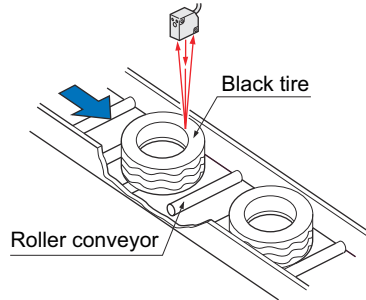

Detecting the remaining amount of roll sheets

Even if roll sheet colors are changed, the sensor can detect them at almost the same distance.

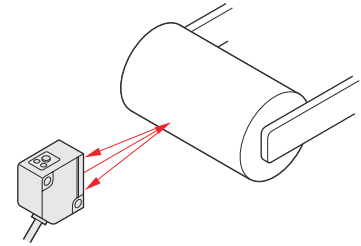

FIBER SENSORS

LASER SENSORS

PHOTO-ELECTRIC SENSORS

MICRO PHOTO-ELECTRIC SENSORS

AREA SENSORS

LIGHT CURTAINS / SAFETY COMPONENTS

PRESSURE / FLOW SENSORS

INDUCTIVE PROXIMITY SENSORS

PARTICULAR USE SENSORS

SENSOR OPTIONS

SIMPLE WIRE-SAVING UNITS

WIRE-SAVING SYSTEMS

MEASUREMENT SENSORS

STATIC ELECTRICITY PREVENTION DEVICES

LASER MARKERS

PLC

HUMAN MACHINE INTERFACES

ENERGY CONSUMPTION VISUALIZATION COMPONENTS

FA COMPONENTS

MACHINE VISION SYSTEMS

UV CURING SYSTEMS

Glossary (Performance overview of the triple beam adjustable range reflective type)

Sensing distance (rated)

- For the triple beam adjustable range reflective type, the maximum distance to operate stably with a standard sensing object is shown.

Setting range (optimum)

- For the triple beam adjustable range reflective type, the range between the maximum and minimum setting distance to operate stably with a standard sensing object is shown. When used beyond this range, there will be a non-detectable area near the sensor. There will also be insufficient light intensity on the far side of the sensor. This will result in unstable sensing. So when setting the sensor, use it within the optimum setting range.

Stability Indicator

- The **MQ-W** series uses PSD for light receiving elements and since sensing is based on the position of the entering beam and not its intensity, the output corresponds to distance. The stability indicator displays the marginal degree of the incident light intensity. So take note that the distance by which the indicator lights on/off varies depending on the reflectance of the sensing object, as shown in the diagram below. Also, do not use the sensor when the stability indicator lights off (Unstable light received condition).

ORDER GUIDE

Type	Appearance	Sensing range	Model No.
Triple beam adjustable range reflective type		40 mm 1.575 in	MQ-W3A-DC12-24V
		200 mm 7.874 in	MQ-W20A-DC12-24V
		700 mm 27.559 in	MQ-W70A-DC12-24V
		40 mm 1.575 in	MQ-W3AR-DC12-24V
		200 mm 7.874 in	MQ-W20AR-DC12-24V
		40 mm 1.575 in	MQ-WN3A-DC12-24V
		200 mm 7.874 in	MQ-WN20A-DC12-24V
		700 mm 27.559 in	MQ-WN70A-DC12-24V
		Standard (infrared)	
Visible light (red)			
Low hysteresis (infrared)			

Selection Guide

Amplifier Built-in

Power Supply Built-in

Amplifier-separated

CX-400

CY-100

EX-10

EX-20

EX-30

EX-40

CX-440

EQ-30

EQ-500

MQ-W

RX-LS200

RX

RT-610

SPECIFICATIONS

Item	Basic Model No.	Triple beam adjustable range reflective							
		40 mm 1.575 in type			200 mm 7.874 in type			700 mm 27.559 in type	
		Visible light	Low hysteresis	Visible light	Low hysteresis	Visible light	Low hysteresis		
		MQ-W3A□	MQ-W3AR□	MQ-WN3A□	MQ-W20A□	MQ-W20AR□	MQ-WN20A□	MQ-W70A□	MQ-WN70A□
Sensing distance (rated)		40 mm 1.575 in with white non-glossy paper (10 × 10 mm 0.394 × 0.394 in)			200 mm 7.874 in with white non-glossy paper (20 × 20 mm 0.787 × 0.787 in)			700 mm 27.559 in with white non-glossy paper (75 × 75 mm 2.953 × 2.953 in)	
Setting range (optimum)		20 to 40 mm 0.787 to 1.575 in with white non-glossy paper (10 × 10 mm 0.394 × 0.394 in)			40 to 200 mm 1.575 to 7.874 in with white non-glossy paper (20 × 20mm 0.787 × 0.787 in)			200 to 700 mm 7.874 to 27.559 in with white non-glossy paper (75 × 75 mm 2.953 × 2.953 in)	
Sensing object		Opaque or translucent object (Note 2)							
Hysteresis (Note 3)		10 % or less of operation distance (with standard sensing object)	5 % or less of operation distance (with standard sensing object)	20 % or less of operation distance (with standard sensing object)	10 % or less of operation distance (with standard sensing object)	20 % or less of operation distance (with standard sensing object)	10 % or less of operation distance (with standard sensing object)	20 % or less of operation distance (with standard sensing object)	10 % or less of operation distance (with standard sensing object)
Supply voltage		9.6 to 30 V DC							
Current consumption		30 mA or less							
Output		NPN open-collector transistor • Maximum sink current: 100 mA • Applied voltage: 30 V DC or less (between output and 0 V) • Residual voltage: 1.2 V or less (at 100 mA sink current)							
Output operation		Selectable either Light-ON or Dark-ON by the control input							
Response time		2 ms or less (Response frequency: 250 Hz or more)							
Operation indicator		Red LED (lights up under light received condition)							
Stability indicator		Red LED (lights up under stable sensing condition)							
Distance adjuster		Continuously variable adjuster							
Environmental resistance	Protection	IP67 (IEC)							
	Ambient temperature	-25 to +55 °C -13 to +131 °F (No dew condensation or icing allowed), Storage: -25 to +55 °C -13 to +131 °F							
	Ambient humidity	85 % RH or less, Storage: 85 % RH or less							
	Ambient illuminance	Incandescent light: 10,000 lx or less at the light-receiving face							
	Voltage withstandability	500 V AC for one min. between all supply terminals connected together and enclosure							
	Insulation resistance	20 MΩ, or more, with 500 V DC megger between all supply terminals connected together and enclosure							
	Vibration resistance	10 to 55 Hz frequency, 1.5 mm 0.059 in amplitude in X, Y and Z directions for two hours each							
Shock resistance	1,000 m/s ² acceleration (100 G approx.) in X, Y and Z directions for six times each								
Emitting element (modulated)		Infrared LED	Red LED	Infrared LED	Red LED	Infrared LED	Red LED	Infrared LED	
Material		Enclosure: Die-cast zinc alloy							
Cable		4-core cable, 2 m 6.562 ft long							
Cable extension		Extension up to total 100 m 328.084 ft is possible with 0.3 mm ² , or more, cable.							
Accessory		Mounting bracket: 1 set							

Notes: 1) Where measurement conditions have not been specified precisely, the conditions use were an ambient temperature of +23 °C +73.4 °F.
 2) Make sure to confirm detection with an actual sensor before use.
 3) This value is from the sensing distance (rated). The standard sensing object is non-glossy paper described in the "Sensing distance (rated)" item.

I/O CIRCUIT AND WIRING DIAGRAMS

I/O circuit diagram

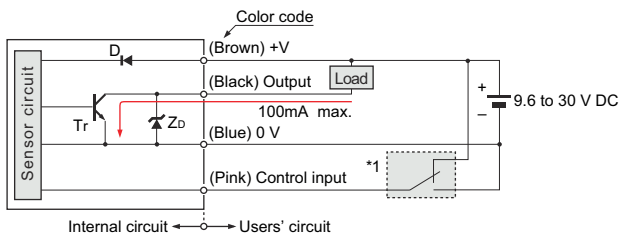

Symbols ... D : Reverse supply polarity protection diode
 Zd: Surge absorption zener diode
 Tr : NPN output transistor

Wiring diagram

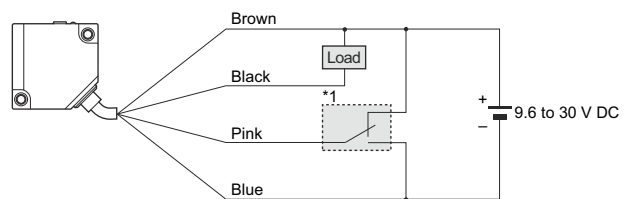

* 1: Selecting output operation by connecting control input wire (pink)

Processing	Output operation
Connected to +V	Light-ON
Connected to 0 V	Dark-ON

FIBER SENSORS

LASER SENSORS

PHOTO-ELECTRIC SENSORS

MICRO PHOTO-ELECTRIC SENSORS

AREA SENSORS

LIGHT CURTAINS/SAFETY COMPONENTS

PRESSURE / FLOW SENSORS

INDUCTIVE PROXIMITY SENSORS

PARTICULAR USE SENSORS

SENSOR OPTIONS

SIMPLE WIRE-SAVING UNITS

WIRE-SAVING SYSTEMS

MEASURE-MENT SENSORS

STATIC ELECTRICITY PREVENTION DEVICES

LASER MARKERS

PLC

HUMAN MACHINE INTERFACES

ENERGY CONSUMPTION VISUALIZATION COMPONENTS

FA COMPONENTS

MACHINE VISION SYSTEMS

UV CURING SYSTEMS

Selection Guide

Amplifier Built-in

Power Supply Built-in

Amplifier-separated

CX-400

CY-100

EX-10

EX-20

EX-30

EX-40

CX-440

EQ-30

EQ-500

MQ-W

RX-LS200

RX

RT-610

SENSING CHARACTERISTICS (TYPICAL)

40 mm 1.575 in Type

Sensing field

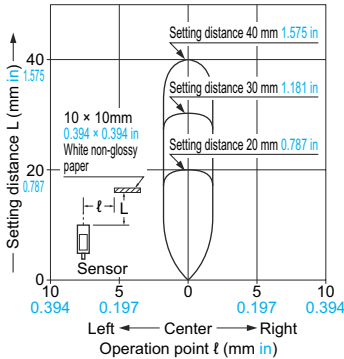

Correlation between sensing object size and sensing range

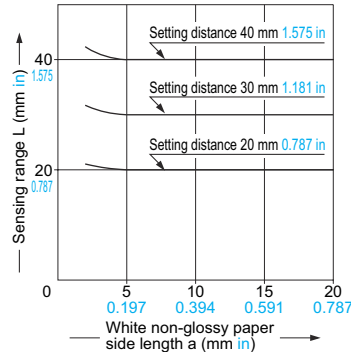

These curves show the characteristics with the maximum sensing range set to 40 mm 1.575 in, 30 mm 1.181 in and 20 mm 0.787 in, with white non-glossy paper (10 × 10 mm 0.394 × 0.394 in).

Correlation between material and sensing range

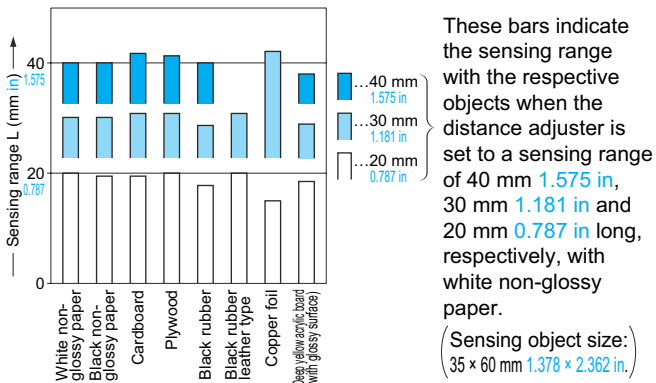

Emitted beam

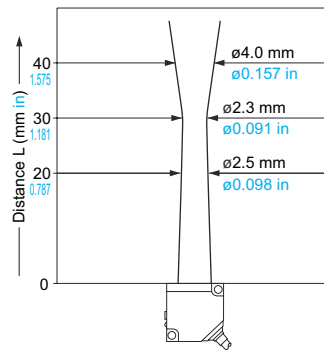

200 mm 7.874 in Type

Sensing field

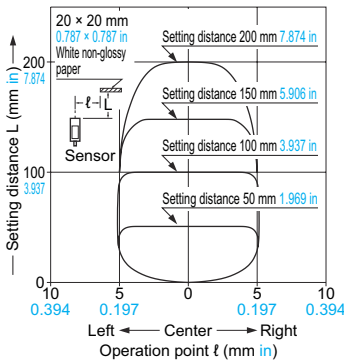

Correlation between sensing object size and sensing range

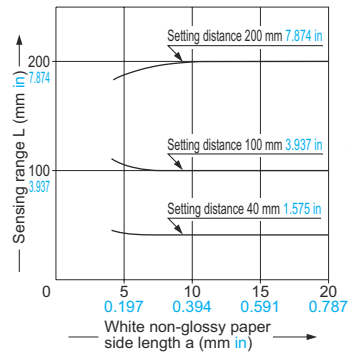

These curves show the characteristics with the maximum sensing range set to 200 mm 7.874 in, 100 mm 3.937 in and 40 mm 1.575 in, with white non-glossy paper (20 × 20 mm 0.787 × 0.787 in).

Correlation between material and sensing range

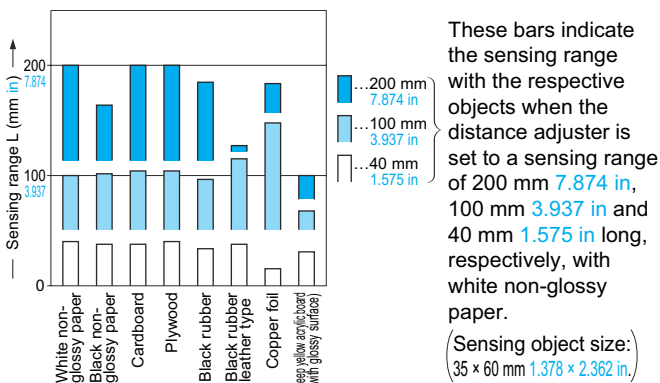

Emitted beam

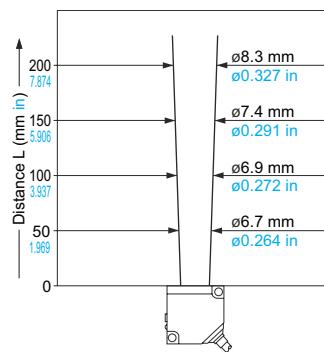

FIBER SENSORS

LASER SENSORS

PHOTO-ELECTRIC SENSORS

MICRO PHOTO-ELECTRIC SENSORS

AREA SENSORS

LIGHT CURTAINS / SAFETY COMPONENTS

PRESSURE / FLOW SENSORS

INDUCTIVE PROXIMITY SENSORS

PARTICULAR USE SENSORS

SENSOR OPTIONS

SIMPLE WIRE-SAVING UNITS

WIRE-SAVING SYSTEMS

MEASUREMENT SENSORS

STATIC ELECTRICITY PREVENTION DEVICES

LASER MARKERS

PLC

HUMAN MACHINE INTERFACES

ENERGY CONSUMPTION VISUALIZATION COMPONENTS

FA COMPONENTS

MACHINE VISION SYSTEMS

UV CURING SYSTEMS

Selection Guide

Amplifier Built-in

Power Supply Built-in

Amplifier-separated

CX-400

CY-100

EX-10

EX-20

EX-30

EX-40

CX-440

EQ-30

EQ-500

MQ-W

RX-LS200

RX

RT-610

SENSING CHARACTERISTICS (TYPICAL)

700 mm 27.559 in Type

Sensing field

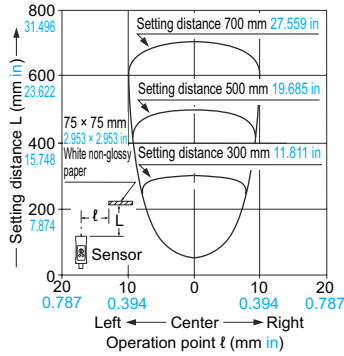

Correlation between sensing object size and sensing range

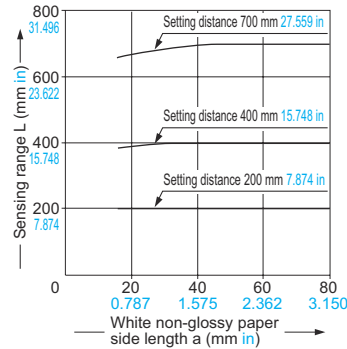

These curves show the characteristics with the maximum sensing range set to 700 mm 27.559 in, 400 mm 15.748 in and 200 mm 7.874 in, with white non-glossy paper (75 × 75 mm 2.953 × 2.953 in).

Correlation between material and sensing range

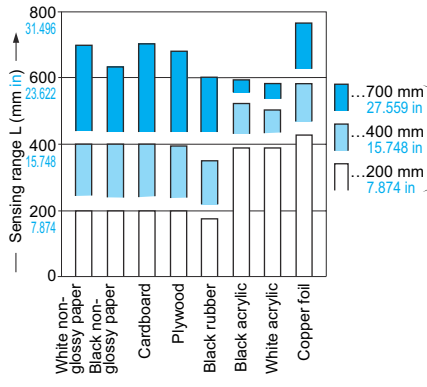

These bars indicate the sensing range with the respective objects when the distance adjuster is set to a sensing range of 700 mm 27.559 in, 400 mm 15.748 in and 200 mm 7.874 in long, respectively, with white non-glossy paper. (Sensing object size: 35 × 60 mm 1.378 × 2.362 in.)

Emitted beam

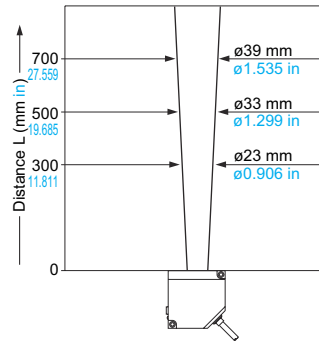

PRECAUTIONS FOR PROPER USE

Refer to p.1458~ for general precautions.



- Never use this product as a sensing device for personnel protection.
- In case of using sensing devices for personnel protection, use products which meet laws and standards, such as OSHA, ANSI or IEC etc., for personnel protection applicable in each region or country.

Case grounding method and insulation mounting bracket

- The **MQ-W** series has an internal circuit that is completely insulated from the enclosure (floating method).

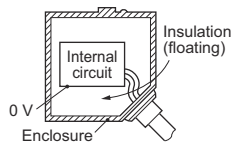

- An exclusive insulation mounting bracket is available in order to improve the anti-noise quality in case there are devices that produce high-frequency noise close to the sensor and the place where the sensor is mounted is an electric conductor (such as metal). Please contact our office for details.

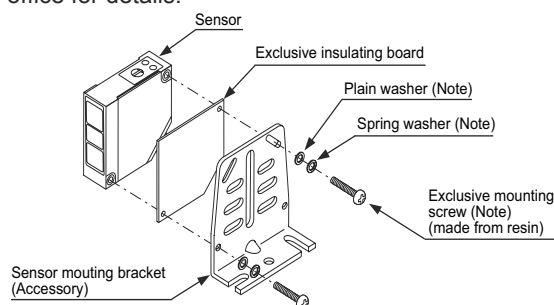

Note: Attached with the exclusive insulating board.

- Performing direct-grounding between the enclosure and circuit 0 V will improve the anti-noise quality.
- Contact our office if you would like to special-order the direct-grounding type that has the enclosure and circuit 0 V connected beforehand.

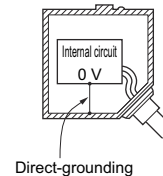

Others

- Do not use during the initial transient time (50 ms) after the power supply is switched on.

- FIBER SENSORS
- LASER SENSORS
- PHOTO-ELECTRIC SENSORS
- MICRO PHOTO-ELECTRIC SENSORS
- AREA SENSORS
- LIGHT CURTAINS/ SAFETY COMPONENTS
- PRESSURE / FLOW SENSORS
- INDUCTIVE PROXIMITY SENSORS
- PARTICULAR USE SENSORS
- SENSOR OPTIONS
- SIMPLE WIRE-SAVING UNITS
- WIRE-SAVING SYSTEMS
- MEASURE-MENT SENSORS
- STATIC ELECTRICITY PREVENTION DEVICES
- LASER MARKERS
- PLC
- HUMAN MACHINE INTERFACES
- ENERGY CONSUMPTION VISUALIZATION COMPONENTS
- FA COMPONENTS
- MACHINE VISION SYSTEMS
- UV CURING SYSTEMS
- Selection Guide
- Amplifier Built-in
- Power Supply Built-in
- Amplifier-separated
- CX-400
- CY-100
- EX-10
- EX-20
- EX-30
- EX-40
- CX-440
- EQ-30
- EQ-500
- MQ-W**
- RX-LS200
- RX
- RT-610

DIMENSIONS (Unit: mm in)

The CAD data in the dimensions can be downloaded from our website.

MQ-W30 MQ-WN30

Sensor

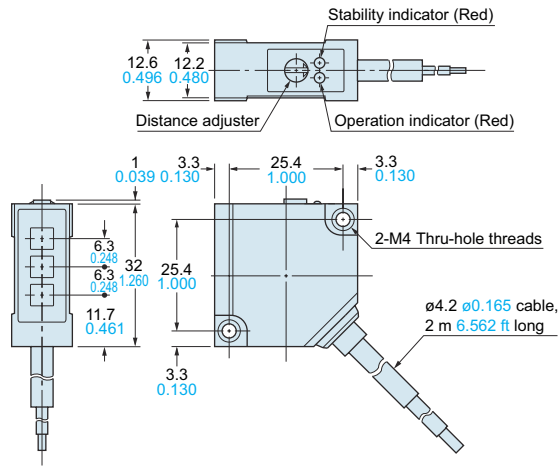

Assembly dimensions with attached mounting bracket

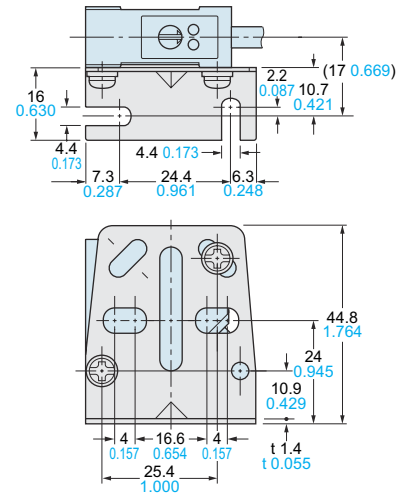

MQ-W200 MQ-WN200

Sensor

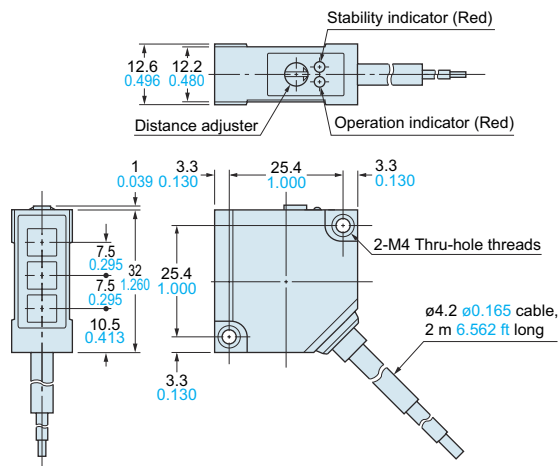

Assembly dimensions with attached mounting bracket

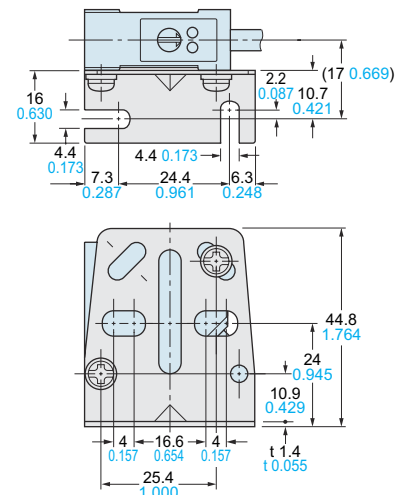

MQ-W700 MQ-WN700

Sensor

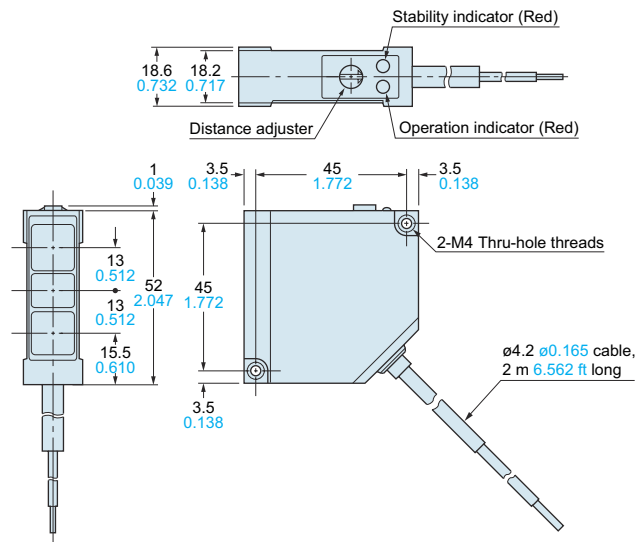

Assembly dimensions with attached mounting bracket

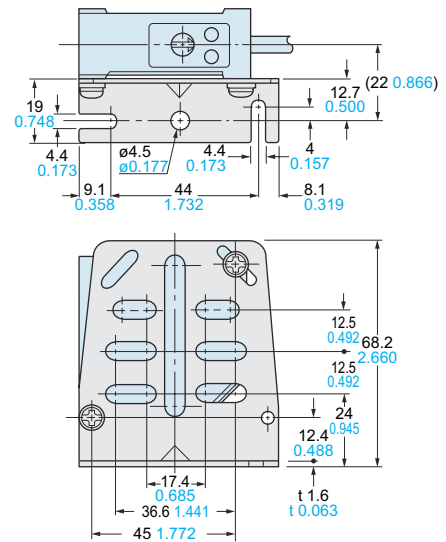

FIBER SENSORS

LASER SENSORS

PHOTO-ELECTRIC SENSORS

MICRO PHOTO-ELECTRIC SENSORS

AREA SENSORS

LIGHT CURTAINS / SAFETY COMPONENTS

PRESSURE / FLOW SENSORS

INDUCTIVE PROXIMITY SENSORS

PARTICULAR USE SENSORS

SENSOR OPTIONS

SMILE WIRE-SAVING UNITS

WIRE-SAVING SYSTEMS

MEASUREMENT SENSORS

STATIC ELECTRICITY PREVENTION DEVICES

LASER MARKERS

PLC

HUMAN MACHINE INTERFACES

ENERGY CONSUMPTION VISUALIZATION COMPONENTS

FA COMPONENTS

MACHINE VISION SYSTEMS

UV CURING SYSTEMS

Selection Guide

Amplifier Built-in

Power Supply Built-in

Amplifier-separated

CX-400

CY-100

EX-10

EX-20

EX-30

EX-40

CX-440

EQ-30

EQ-500

MQ-W

RX-LS200

RX

RT-610