

RoHS Compliant

# Specification of SAW Filter

Part No. : SF14-2446M5UUA3

Oct., 14, 2014

Kyocera Corporation, Electronic Components Group, Circuit Device Dept.

Approved by

H. Arikawa

Design Engineering

Checked by

T. Ohbayashi

Design Engineering

Issued by

E. Ohtsuka

Design Engineering

**Revision History**

Revision	Date	Description
00	Jul., 13, 2012	Initial release
01	Aug., 30, 2014	Modify operating temperature range to -40~+85deg.C
02	Oct., 14, 2014	Modify test condition of humidity storage, high temperature storage, low temperature storage and temperature cycle of table 4

## 1. Scope

This specification shall cover the characteristics of the RF SAW filter for WLAN.

## 2. KYOCERA's Part No.

SF 14 - 2446 M 5 UU A3  
 (a) (b) (c) (d) (e) (f) (g)

(a)	Series	(e)	Terminals
(b)	Package Size	(f)	In/Out Condition
(c)	Frequency	(g)	Custom Specification
(d)	Type		

## 3. Production Site

KYOCERA Kagoshima Kokubu Plant, Japan

## 4. Rating

Table 1

Items	Rating	Unit	Note
Operating Temperature Range	$\triangle$ -40 to +85	deg.C	
Storage Temperature Range	-40 to +85	deg.C	
Max Input Power	+24	dBm	10,000Hours, Ta=65 deg.C
Nominal Input Impedance	50//2.7nH	ohm	Unbalance
Nominal Output Impedance	50//2.7nH	ohm	Unbalance

## 5. Measurement Temperature

It measures at normal temperature (25+/-2deg.C), and the electrical property (Table 2) within the operational temperature range is guaranteed.

## 6. Measurement Circuit

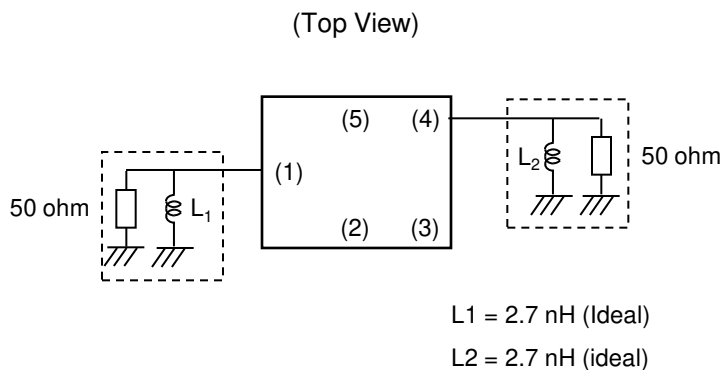

Pin No.	Function
(1)	Input
(2)	GND
(3)	GND
(4)	Output
(5)	GND

## 7. Electrical Characteristics

Table 2

Items	Frequency (MHz)	Specification			Unit	Note
		min.	typ.	max.		
Insertion Loss	2400 to 2493	-	1.5	2.3	dB	
Ripple	2400 to 2493	-	0.3	1.4	dB	
Input VSWR	2400 to 2493	-	1.3	2.1	-	
Output VSWR	2400 to 2493	-	1.3	2.1	-	
Absolute Attenuation	875 to 885	50	59	-	dB	
	869 to 894	50	58	-	dB	
	925 to 960	50	56	-	dB	
	1477 to 1501	38	44	-	dB	
	1574.42 to 1576.42	38	44	-	dB	
	1805 to 1880	30	37	-	dB	
	1930 to 1990	28	33	-	dB	
	2110 to 2155	28	38	-	dB	
	2110 to 2170	28	36	-	dB	
	2595 to 2625	30	39	-	dB	
4800 to 5805	23	27	-	dB		

## 8. Dimensions

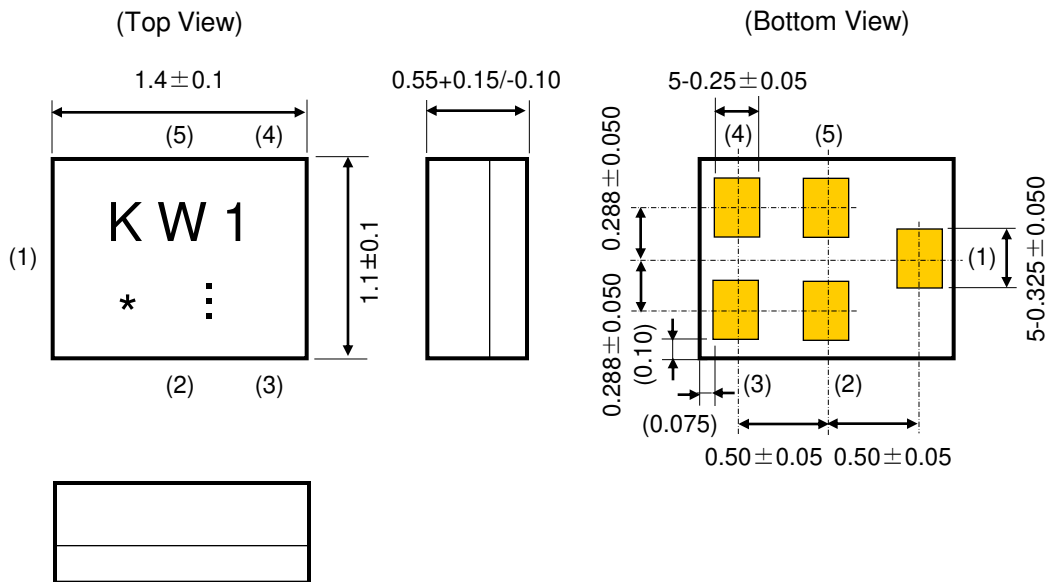

Unit	: mm
Terminal quality of the material	: Ni (1.0um min.) : Au (0.02um min.)
The degree of terminal flat	: 0.10mm max.
K	: KYOCERA logo
W1	: Identification no.
*	: Monthly code
⋮	: Index mark of ten days ( ⋮ : 1~10, : 11~20, · 21~31)

Table 3. Monthly Code Production

Year	Month	Code	Year	Month	Code	Year	Month	Code	Year	Month	Code
2011	1	a	2012	1	n	2013	1	A	2014	1	N
2015	2	b	2016	2	p	2017	2	B	2018	2	P
	3	c		3	q		3	C		3	Q
	4	d		4	r		4	D		4	R
	5	e		5	s		5	E		5	S
	6	f		6	t		6	F		6	T
	7	g		7	u		7	G		7	U
	8	h		8	v		8	H		8	V
	9	j		9	w		9	J		9	W
	10	k		10	x		10	K		10	X
	11	l		11	y		11	L		11	Y
	12	m		12	z		12	M		12	Z

## 9. Recommendable Land Pattern

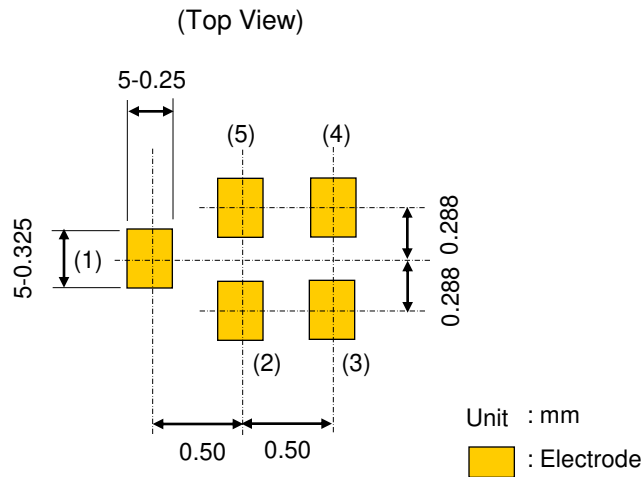

## 10. Recommendable Reflow Soldering Profile

Temperature measurement point is surface of glass epoxy circuit board.  
 Reflow 2 times max.

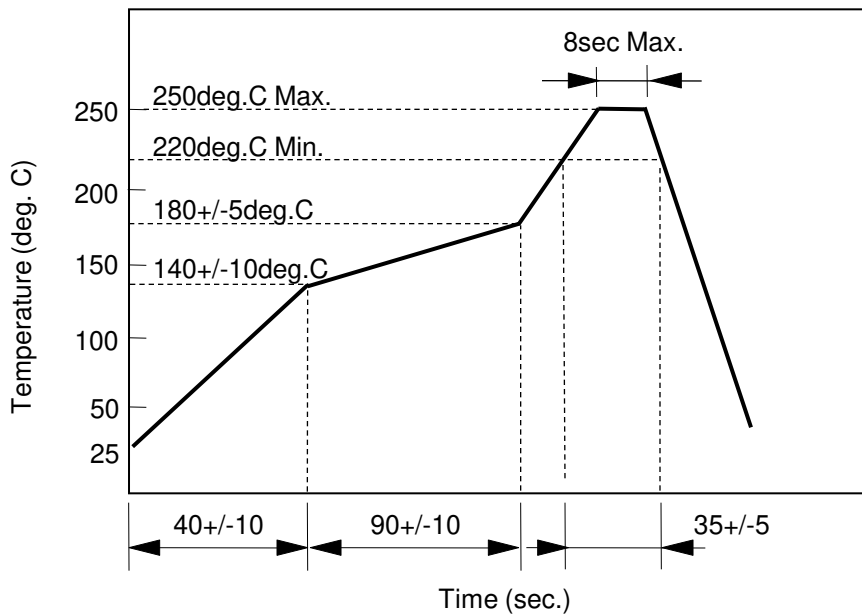

## 11. Environmental Characteristics

Table 4

Item	Condition
2 Humidity Storage	Subject the filter to 85+/-2deg.C and 85+/-2%RH for 1,000hours. Then, release the filter into the room conditions for 2hours minimum to the measurement. It shall fulfill the specifications in Table 2.
2 High Temperature Storage	Subject the filter to 85+/-2deg.C for 1,000hours. Then, release the filter into the room conditions for 2hours minimum to the measurement. It shall fulfill the specifications in Table 2.
2 Low Temperature Storage	Subject the filter to -40+/-2deg.C for 1,000hours. Then, release the filter into the room conditions for 2hours minimum to the measurement. It shall fulfill the specifications in Table 2.
2 Temperature Cycle	1,000 cycles (1cycles : -40deg.C for 30minutes then 85deg.C for 30minutes.) An examination is done under the evaluation circuit board mounting condition. Then, release the filter into the room conditions for 2hours minimum to the measurement. It shall fulfill the specifications in Table 2.
Random Drop	Drop the filter randomly onto a concrete floor from the height of 1m, 3times. It shall fulfill the specifications in Table 2.
Vibration	Subject the filter to vibration for 2hour each in the X,Y and Z axes with the amplitude of 1.5mm, 10 to 55Hz/min. It shall fulfill the specifications in Table 2.
Resistance to Reflow Solder Heat	Expose filter to increasing temperature with Recommendable Reflow Soldering Profile, twice. Then, release the filter into the room conditions for 2hours minimum to the measurement. It shall fulfill the specifications in Table 2.
Circuit Board Deflection	It is mounted on the circuit board for the evaluation, and the center of the circuit board is pushed from the product mounting side and the anti-interview, and a circuit board is made to sag 2mm. It carried out 3times in X and the direction of Y, respectively. ( Fig.-1 ) There are not mechanical damage and electrode detachment
ESD	A direct current voltage is increased to DEVICE mounted on the evaluation circuit board. The failure rate which occurred by the direct current voltage is investigated. A direct current voltage begins from 39V. As for the voltage, it increases with step of E12 series. A failure voltage is prescribed in the direct current voltage that an accumulate trouble rate is 10%. It is judged with the trouble when increase in the insertion loss occurs beyond 0.3dB before and after the examination. A failure voltage is more than 50V. ( Fig.-2 )

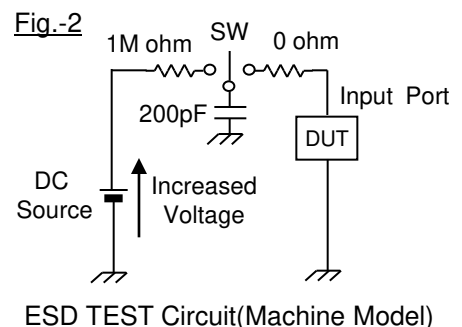
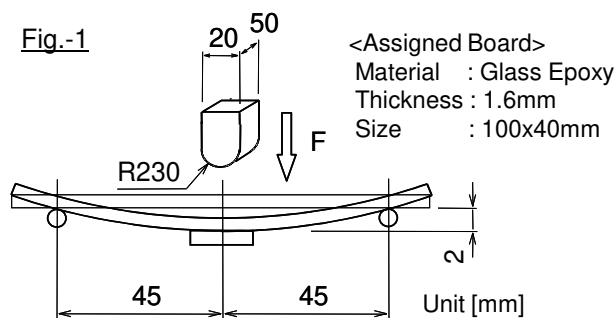

## 12. Taping Specification

### 12-1. Tape Material

Polyester resin, or Polystyrene resin (conductivity type)

### 12-2. Tape Dimensions

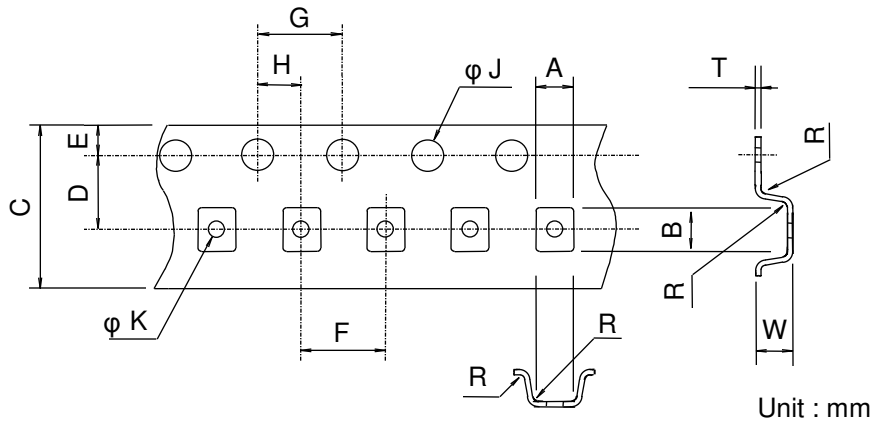

Unit : mm

Part	A	B	C	D	E
Dimension	$1.4 \pm 0.1$	$1.7 \pm 0.1$	$8.0 \pm 0.2$	$3.50 \pm 0.05$	$1.75 \pm 0.10$
Part	F	G	H	$\phi J$	$\phi K$
Dimension	$4.0 \pm 0.1$	$4.0 \pm 0.1$	$2.00 \pm 0.05$	$1.5 \pm 0.1$	$0.50 \pm 0.05$
Part	R	W	T		
Dimension	0.3 Max	$0.8 \pm 0.1$	$0.20 \pm 0.05$		

\* W Dimension is depth of pockets.

### 12-3. Taping Quantity

One reel of tape shall pack 3,000 filters maximum.

No filter shall be missing and contained continuously in pocket.

### 12-4. Reel Material

Polystyrene resin (conductivity type)

### 12-5. Reel Dimensions

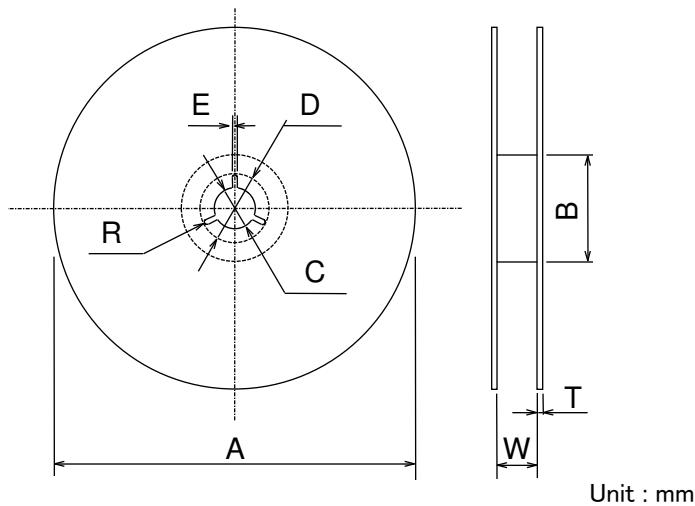

Unit : mm

Part	A	B	C	D
Dimension	$178 \pm 2$	$60 \pm 2$	$13.0 \pm 0.2$	$21.0 \pm 0.8$
Part	E	R	W	T
Dimension	$2.0 \pm 0.5$	1	$9.5 \pm 1.0$	$2.0 \pm 0.2$



12-6. Leader and blank pocket

Package shall consist of Leader and Blank Pocket, and packaging direction is as following.

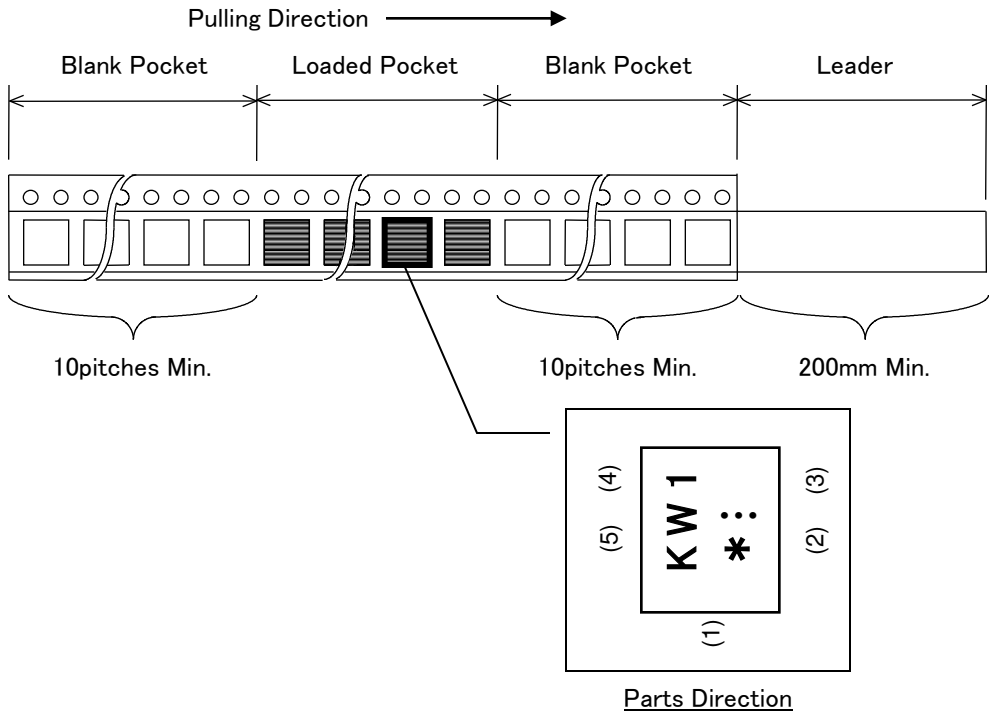

12-7. Taping peel strength

The taping peel test condition, method and peeling strength range are described as following.

Test condition : 120mm/min. 160~180°  
 Peel strength range : 0.1~1.0N

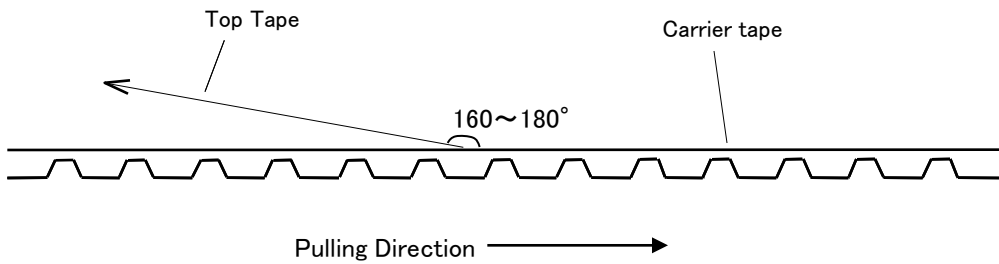

12-8.Reel Label

The following contents are indicated in a reel. (based on EIAJ-C3 label)

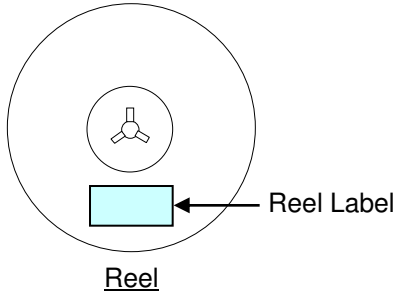

- Customer Parts Name
- Quantity
- Manufacturing Parts Name
- Lot Number
- Shipping Date
- Delivery corporate name

12-9. Aluminum Packing Label

We place care instruction, reel label and MSL label on the front of aluminum hermetic container.

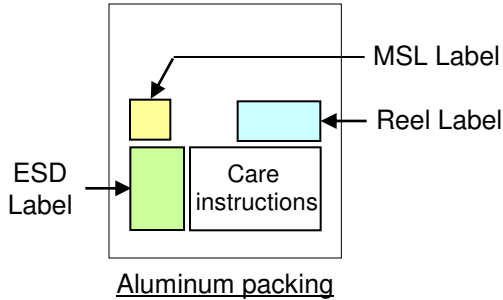

12-10. Packing Form / Packing Case Label

During transportation, after packing into an aluminum packing for every reel so that a damage and moisture absorption may not be given to a product, it puts into a packing box.

The following contents are indicated in a packing case. ( based on EIAJ-C3 label)

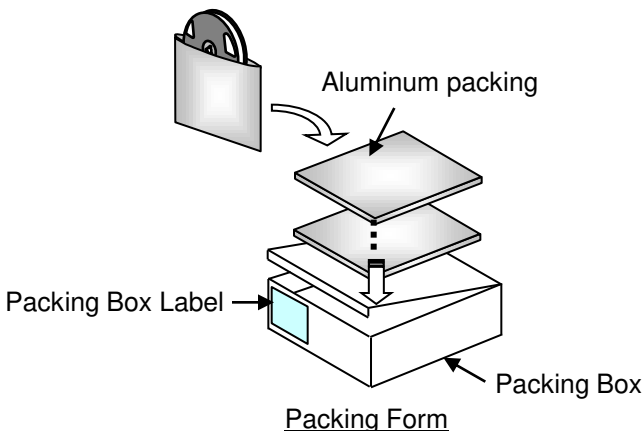

- Customer Parts Name
- Quantity
- Manufacturing Parts Name
- Lot Number
- Shipping date
- Delivery corporate name

## 13. Precaution in handling

### 13-1. Application instructions

- 1) This product is designed to be used for general electronic device and is not designed in the high reliability application listed below.

Please inform the department in charge when using the product for following applications.

Utility in nuclear power plant	Traffic signal control system
Utility in space	security and disaster-prevention
Aircraft	Transporter (car, train, ship, etc.)
under water or ground	Medical
other – applications requires same environmental status as above.	

- 2) This product must not be used in every application which are primary – intended to damage human race or their property.

Arms (missile, bomb and other application to damage human)  
 Weapons (transports act for combat )  
 Controller with primary – intended to military use.

### 13-2. Operating Environment

- 1) Use this product within the certified operating temperature.

If not, it may not fulfill the requested electrical characteristic. It may move successfully for a short time, but it will cause degradation or breakdown, moreover lower the reliability.

- 2) This product is designed and manufactured with intention to be used in general electronic equipments for standard applications but with no intention to be used in the following environments which may affect performance of this product.

Therefore, make sure to have enough confirmation on performance and reliability of this product in the following environments in advance before use.

- Under corrosive gas (Cl<sub>2</sub>, H<sub>2</sub>S, NH<sub>3</sub>, SO<sub>x</sub>, NO<sub>x</sub>, etc.)
- Under volatile and inflammability gas
- Dusty environment
- Under water trickle or dew drop occur from humid.
- Under direct sunlight
- Under high static charge or electric intensity.

Please inform the department in charge when using the product for the application above.

- 3) This product can't be used in liquid (water, oil, chemical, organic solvent)

- 4) Please use under certified voltage.

If not, it may not fulfill the requested electrical characteristic. It may move successfully for a short time, but it will cause degradation or breakdown, moreover lower the reliability.

- 5) The face resin is not on the purpose of insulation, do not contact with other components.

- 6) There might be a strong electrical charge when rapid thermal change is added to this product. This charge may damage this product and the surrounding circuit. Therefore, please load discharge path between output-Ground , input-Ground.

- 7) Please do not load larger stress loaded under the environmental test.

It may move successfully for a short time, but it will cause degradation or breakdown, moreover lower the reliability.

- 8) Do not mold this product by transfer molding. It may not have a normal operation from the sealing break. Please inform the department in charge when molding by resin.

### 13-3. Storage instructions

1) Please do not store under following condition. Solderability might deteriorate.

- Under corrosive gas (Cl<sub>2</sub>, H<sub>2</sub>S, NH<sub>3</sub>, SO<sub>x</sub>, NO<sub>x</sub>, etc.)
- Under volatile and inflammability gas
- Dusty environment
- Under water trickle or dew drop occur from humid.
- Under direct sunlight
- Under high static charge or electric intensity.

Please inform the department in charge when storing or handling the product under the environment.

2) Store this product under normal temperature , normal humidity with sealed or unopened package. Store more than the maximum storage limit 12months after shipment, the solderability might deteriorate. Therefore, make sure and test before using. Also, the electrode might change color during a long term storage.

3) Open the seal pack just before using.

After opening, please mount onto the board under 5-30deg.C, below 60%RH within 168 hours.

4) When stocking the box too high, it might fall down. Please stock the box within 5 boxes.

### 13-4. Handling instructions

1) Please do not load larger vibration or shock loaded under the environmental test while handling. It may cause degradation or breakdown and moreover lower the reliability.

2) Please do not load larger shock or stress than environmental test while handling the board with this product mounted.

3) Please handle this product with static electric and high voltage countermeasures. If static electric are loaded, degradation or damage may happen.

4) Do not handle this product with bear hand.

### 13-5. Placing instructions

1) Do not mount on the place where has a large stress while bending and bowing the board. There might be a large stress or shock when it's placed near the connection parts with other outer parts.

2) Please do not load larger stress than environmental test while mounting on the board.

3) Please bond every electrode with solder. If not, the electrode strength might lower.

## 13-6. Recommendable rework condition

1) Following status is recommended for the rework.

○Reflow solder

Please reflow by the recommended reflow profile

○Heat gun (Spot heater)

Pre-heating : 150deg.C +/- 10deg.C min 60sec

Hot air : 280deg.C +/- 10deg.C max 30 sec

2) The chip might break from the mechanical stress if there are too much solder on the land pattern.  
Please design the land pattern area and solder volume within the recommended status.

3) Please mount this product by reflow. Characteristic degradation or damaging the product might occur when rapid temperature change happens by short pre-heating.  
Please inform the department in charge if there are plans to use this product far from the condition described above.

4) The heating limit time when using heat gun repeatedly, will be the sum total time.

## 13-7. Recommended washing conditions

1) While washing the board after soldering, following conditions are recommended.

Avoid using Fluorocarbon and Trichloroethane from the environmental protection.

Washing medicine Kao.CO. Clean through 750H  
Isopropyl alcohol,  
ethyl alcohol

<u>Washing condition</u>	medicine wash	60 deg.C, 90 sec
	pure water wash	60 deg.C, 90 sec
	drying	80 deg.C, 30 min

2) Washing after reflow might cause product degradation from rapid temperature change.  
Please make sure the products are fully cooled to the room temperature.

3) Supersonic may cause characteristic degradation. Avoid supersonic wash.

4) Please dry the product within 60 minute after washing.

5) Please test and estimate the quality by actual product board before washing.

## 13-8. General information

If we stop the production of this product, we will let you know in writing a part number, the lifecycle reason, the discontinued time and the supply period for discontinued after six months ago as a general rule.

## 13-9. Warning about approval sheet

1) Test with actual product board before using.

2) Do not use without any depart from this specification sheet.