

**DESCRIPTION**

The LX2206 can be used with a wall adapter or USB power source to charge a single cell Lithium Ion or Lithium Polymer battery. There are two logic selectable and programmable charge current levels which can be set from anywhere between 50mA to 1A. The termination current is 1/10 the charge level set by the High Level Programming Current Pin.

Power status indicators (STAT and DCOK) can be configured to show charge in progress, battery fully charged and external power on. The STAT pin is capable of sourcing or sinking 10mA. The DCOK output is an open drain output.

The LX2206 enters a low quiescent current sleep mode when power is removed or when it is logically shutdown to minimize battery drain.

There are several protection features which include: under voltage lock out, inrush current limiting, reverse current blocking on the IN pin, a thermal loop to reduce charge current to maintain a low die temperature, an unsafe battery temperature charge inhibitor, and conditioning mode is provided for deeply discharged batteries.

**KEY FEATURES**

- Two Independent Programmable Charge Currents
- 0.5% Float Voltage Tolerance
- Charging up to 1A.
- Charging from USB Port.
- USB Current Compliance
- Full Battery Indicator
- CC/CV w Thermal Feedback
- Battery Temperature Monitor
- Precision Charge Termination
- Power Good Indication

**APPLICATIONS**

- MP3 Player
- PDA
- PMC
- Digital Camera
- Charge Cradle

**IMPORTANT:** For the most current data, consult MICROSEMI's website: <http://www.microsemi.com>

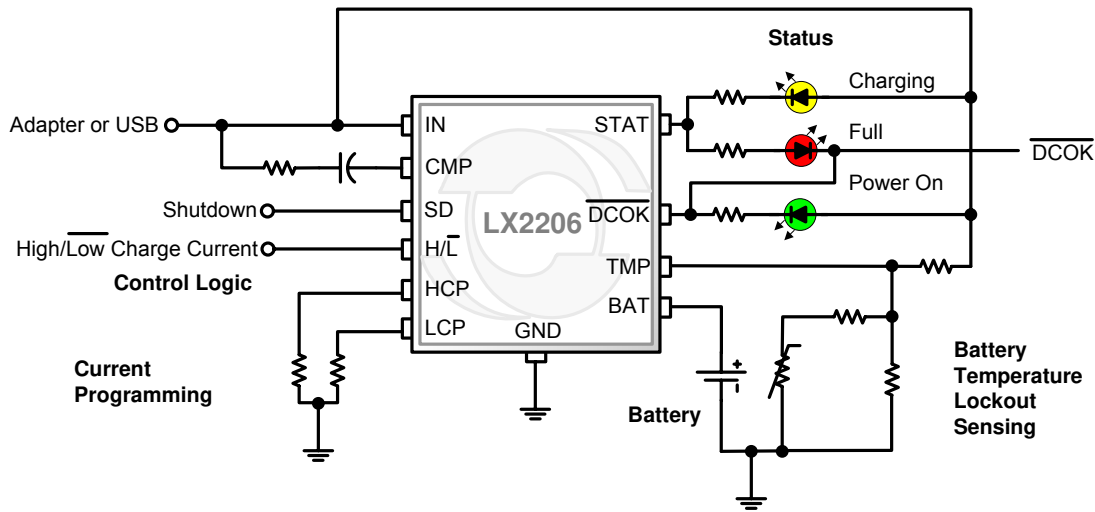
**PRODUCT HIGHLIGHT**

**PACKAGE ORDER INFO**

$T_A$ (°C)	<b>LD</b> Plastic MLPD 10-Pin
	RoHS Compliant / Pb-free
-40 to 85	<b>LX2206ILD</b>

Note: Available in Tape & Reel. Append the letters "TR" to the part number. (i.e. LX2206ILD-TR)

**ABSOLUTE MAXIMUM RATINGS**

Supply Input Voltage (IN, BAT) .....	-0.3V to 7V
All other pins .....	-0.3V to $V_{SUPPLY}$
Battery Charging Current .....	1.1A
Operating Temperature Range .....	-40 to 150°C
Maximum Operating Junction Temperature .....	150°C
Storage Temperature Range .....	-65°C to 150°C
Lead Temperature (Soldering 10 seconds).....	300°C
Package Peak Temp. for Solder Reflow (40 seconds maximum exposure) ...	260°C (+0 -5)

Note: Exceeding these ratings could cause damage to the device. All voltages are with respect to Ground. Currents are positive into, negative out of specified terminal.

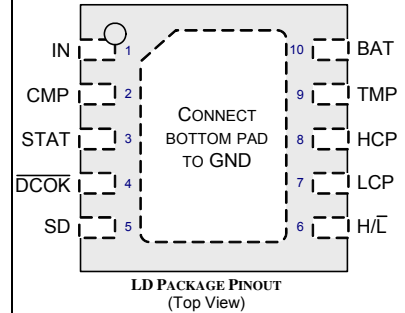
**PACKAGE PIN OUT**

RoHS / Pb-free 100% matte Tin Pin Finish

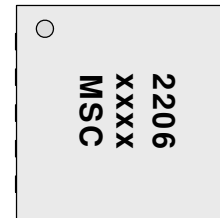

Part Marking  
xxxx = Denotes date and  
lot code Identification

**THERMAL DATA**
**LD Plastic Micro Leadframe Package 10-Pin**

<b>THERMAL RESISTANCE-JUNCTION TO AMBIENT, <math>\theta_{JA}</math></b>	<b>33°C/W</b>
-------------------------------------------------------------------------	---------------

Junction Temperature Calculation:  $T_J = T_A + (P_D \times \theta_{JA})$ .

The  $\theta_{JA}$  numbers are guidelines for the thermal performance of the device/pc-board system. All of the above assume no ambient airflow.

**FUNCTIONAL PIN DESCRIPTION**

Name	Description
BAT	Battery – Connect to a single cell Lithium Ion Battery.
CMP	Compensation – Connect the series combination of a 1k resistor and a 0.47 $\mu$ F capacitor from CMP to IN.
DCOK	Power status logic pin and LED driver – This pin is an open drain output that can sink 20mA of current to drive an external LED. This pin is low impedance to GND when the Input voltage is high enough to charge the Battery.
GND	Ground – Connect to the system ground plane. Use sufficient via copper area to allow for thermal conduction from the IC to the GND plane.
HCP	High Current Programming (and Termination Current Programming) – Connect a resistor to ground to set the constant current high level. The termination current is set to 1/10 of the High Current Programming Level. For a value of 19.6K, the High Current is 460mA and the Termination Current is 46mA.
H/L	High or Low load select logic input – A logic high selects the constant charge current level set by the HCP pin resistor and a logic low selects the constant charge current level set by the LCP pin resistor
IN	Input Power – Connect to a wall adapter or a USB power plug.
LCP	Low Current Programming – Connect a resistor to ground to set the constant current low level. For a value of 110K, the Low Current is 92mA.
SD	Shutdown – A logic high places the LX2206 in sleep mode; can also be used for USB suspend.
STAT	Charging status logic pin and LED driver – This pin can source or sink 10mA of current to drive an external LED in either output state. This pin is low (current sinking mode) when the battery is in charging mode and becomes high (current sourcing mode) when the charge cycle is finished. It becomes a high impedance when the input power is removed.
TMP	Battery Temperature Monitor – This sense pin determines the battery temperature for charging out of temperature range lockout and is connected to a resistor network as defined in the Applications section. The TMP pin is grounded if this function is not used.

**ELECTRICAL CHARACTERISTICS**

Unless otherwise specified, the following specifications apply over the operating ambient temperature  $-40^{\circ}\text{C} \leq T_A \leq 85^{\circ}\text{C}$  except where otherwise noted and the following test conditions:  $I_N = 5.0\text{V}$ ; SD = Low; H/L = High; BAT = 3.6V;  $H_{CP} = 19.6\text{k}$ ; LCP = 110k; TMP = 0V.

Parameter	Symbol	Test Conditions	LX2206			Units
			Min	Typ	Max	
<b>INPUT CIRCUITRY</b>						
Input Voltage	$V_{IN}$		4.35		6	V
Battery Voltage	$V_{BAT}$				4.3	V
Under Voltage Charging Lockout	$V_{INUVLO}$	Rising input $V_{BAT} = 3.2\text{V}$	3.5	3.8	4	V
UVLO Hysteresis				300		mV
Input Supply Current	IIN	$V_{BAT} = 4.2\text{V}$ ; battery charged		1	2	mA
		SHDN = High		35	50	$\mu\text{A}$
<b>BATTERY CHARGER</b>						
Constant Voltage Charging	$V_{CVL}$	$I_{BAT} < 100\text{mA}$	4.16	4.2	4.24	V
Constant Voltage Charging	$V_{CVL}$	$I_{BAT} < 100\text{mA} @ 25\text{C}$	4.18	4.2	4.22	V
HCP Bias Voltage	$V_{HCP}$	$I_{BAT} > 100\text{mA}$		1.25		V
LCP Bias Voltage	$V_{LCP}$			1.25		V
Battery Charge Current	$I_{BAT}$	HCP = 12.1k	650	710	750	mA
		H/L = Low	420	460	483	mA
Conditioning Current	$I_{COND}$	$V_{BAT} < V_{CCT}$ ; HCP = 19.6k	13	23	33	mA
Conditioning Current	$I_{COND}$	$V_{BAT} < V_{CCT}$ ; HCP = 110k	2.6	5.0	7.5	mA
Cond. Current Threshold	$V_{CCT}$		2.5	2.7	2.9	V
Charge Termination Current	$I_{BAT}$	HCP = 19.6k	34	46	59	mA
Charge Termination Current	$I_{BAT}$	HCP = 110k		9		mA
Charge Termination Current	$I_{BAT}$	HCP = 210k		5		mA
Top Off Threshold	$V_{TOT}$		96	97	98	$\% \frac{V_{BAT}}{V_{CVL}}$
Battery Drain Current	$I_{BAT}$	$V_{BAT} = 4.2\text{V}$ ; battery charged		1	30	$\mu\text{A}$
		$V_{BAT} > V_{IN}$ SD = High (Shutdown Mode)		5	30	$\mu\text{A}$
				1	5	$\mu\text{A}$
<b>LOGIC</b>						
STAT Logic High Output	$V_{DRV}$	$V_{IN} = 5.0\text{V}$ , $I_{DRV} = -10\text{mA}$	4.2	4.5	5	V
STAT Logic Low Output	$V_{DRV}$	$V_{IN} = 5.0\text{V}$ , $I_{DRV} = 10\text{mA}$			0.5	V
Input Logic : SD, H/L	$V_{LOG(IN)}$	Logic Hi,	1.2			V
		Logic Lo			0.4	V
Input Current : SD, H/L	$I_{LOG(IN)}$	Logic Hi, $V_{LOG} = 2\text{V}$	0	2	4	$\mu\text{A}$
		Logic Lo, $V_{LOG} = 0\text{V}$	-2	0	2	$\mu\text{A}$
Output Logic : $\overline{\text{DCOK}}$	$V_{LOG(OUT)}$	Logic Hi, $I_{LOG} = 10\text{k}$ pullup to 3.3V	3.1			V
		Logic Lo, $I_{LOG} = 20\text{mA}$			0.5	V
<b>BATTERY TEMPERATURE MONITOR</b>						
Cold Temp Fault Threshold	VCOLD	Rising Threshold		0.75 x $V_{IN}$		V
		Falling Threshold		0.72 x $V_{IN}$		V
Hot Temp Fault Threshold	VHOT	Falling Threshold		0.28 x $V_{IN}$		V
		Rising Threshold		0.30 x $V_{IN}$		V
TFB Disable Voltage	VDIS		75	100	150	mV

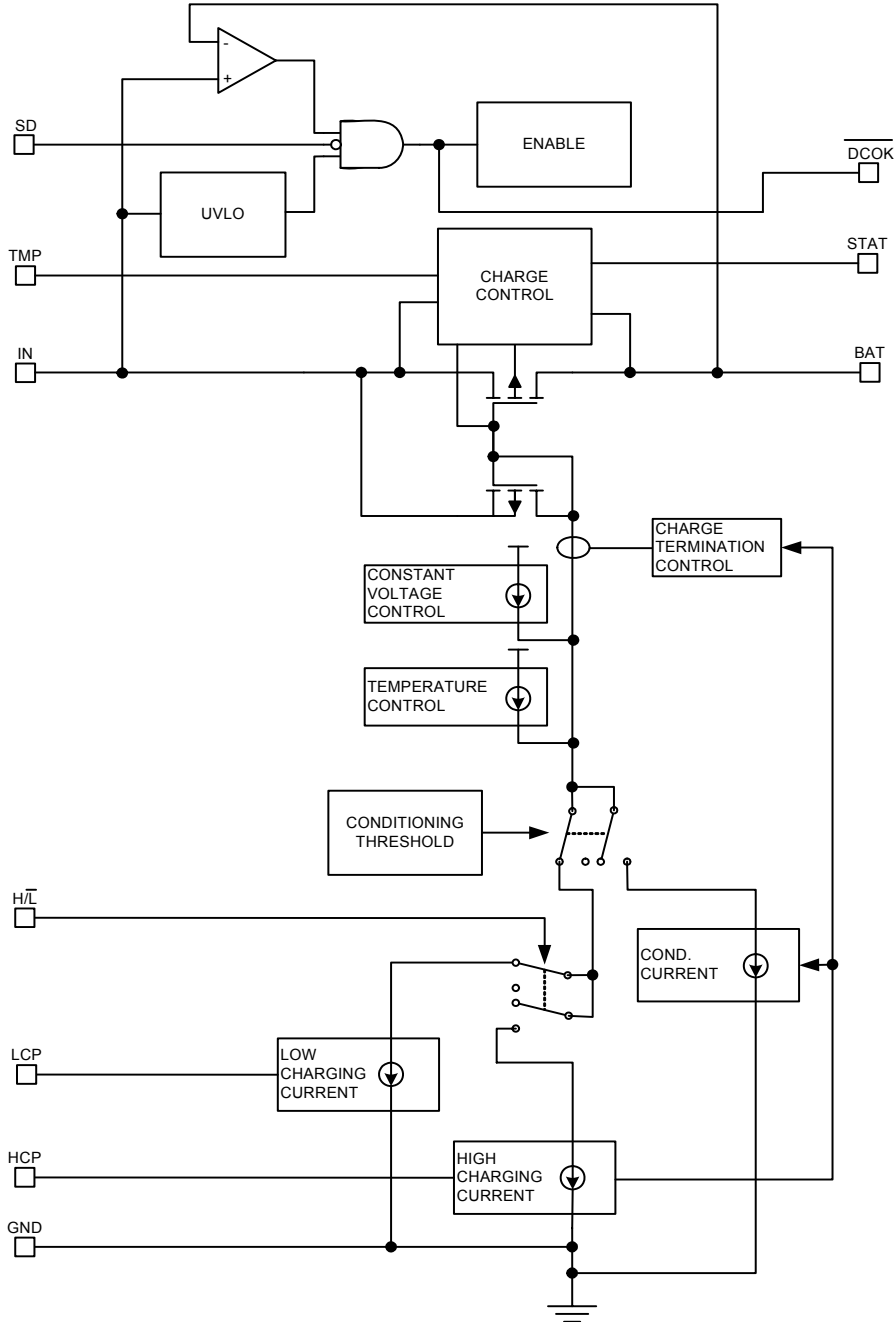
**SIMPLIFIED BLOCK DIAGRAM**

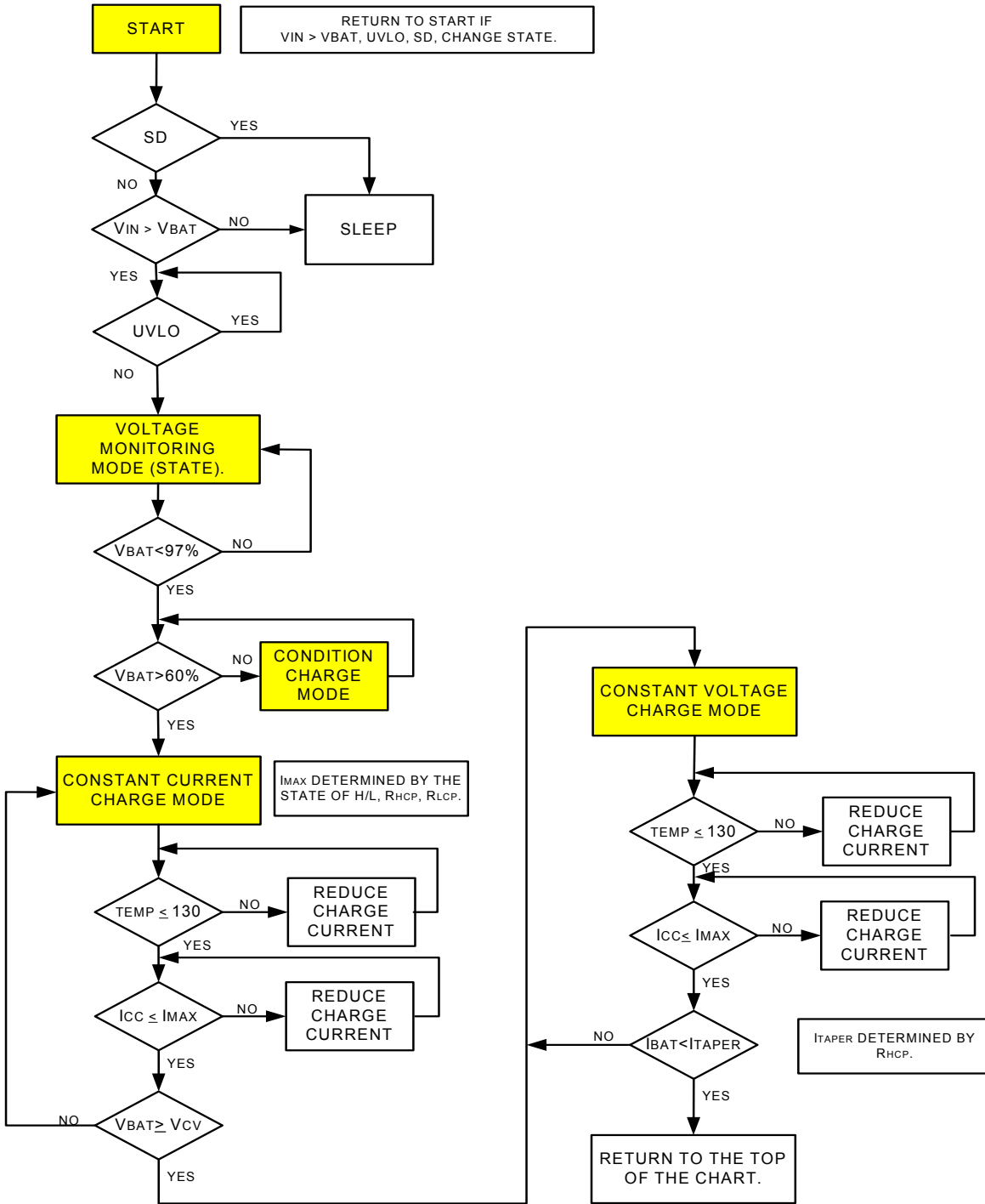
**CONTROL LOGIC DIAGRAM**

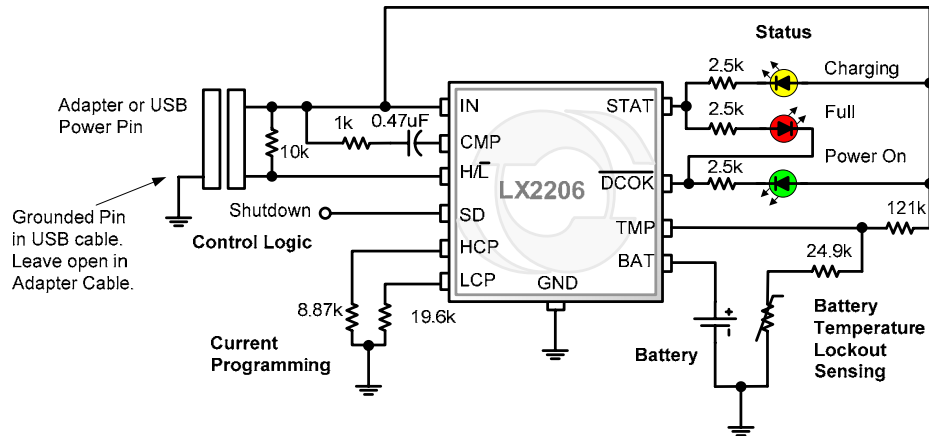
**APPLICATION CIRCUITS**

**Figure 1** – Typical Application – 1A or 500mA maximum charge currents with three indicators and battery temperature lockout. A grounded spare pin in the USB power cable can be used to sense when the 500mA USB current power source is being used.

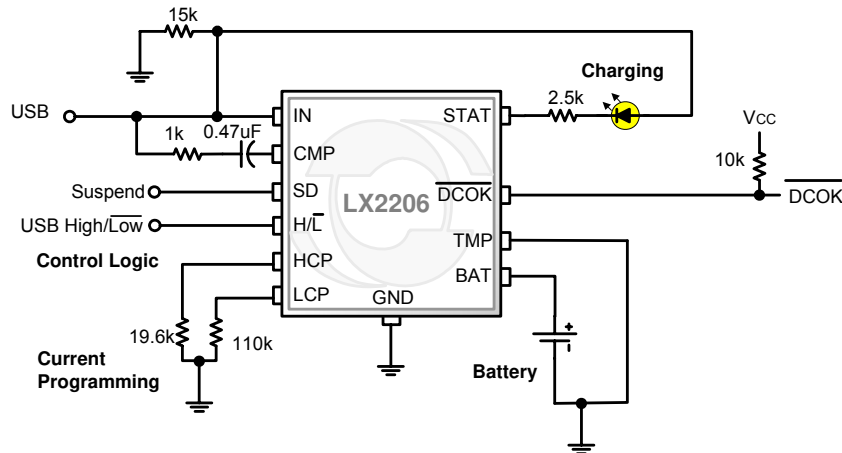

**Figure 2**– Typical USB Application – 500mA or 100mA maximum charge currents with charge indicator.

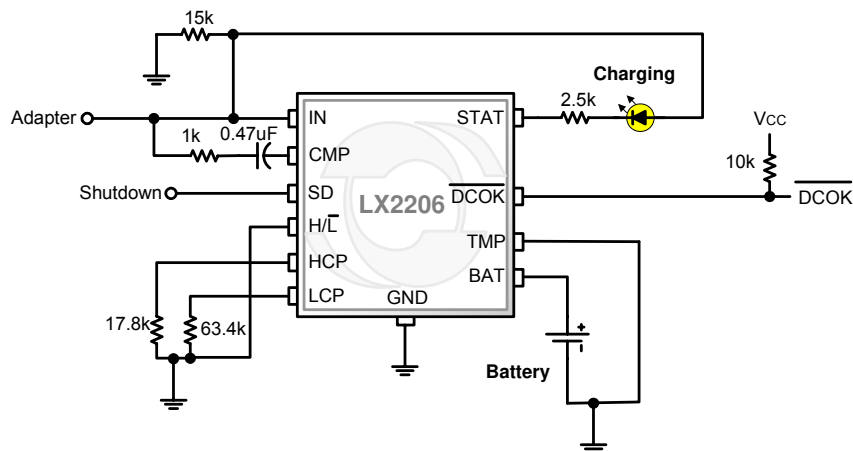

**Figure 3** – Typical Low current application – 150mA charge current and 50mA termination current.

**THEORY OF OPERATION****GENERAL DESCRIPTION**

The LX2206 is designed to charge a single cell Lithium Ion battery using two steps: a constant current mode followed by a constant voltage mode. The maximum charging current during the Constant Current Mode of the charging profile can be logically set (using H/L) to two preprogrammed levels set by resistors connected to HCP and LCP (High and Low current). The charger will terminate constant voltage charging once the current drops below the taper current setting which is 10% of the high charge current setting (determined by HCP resistor value).

**CONDITIONING CURRENT CHARGE MODE**

A conditioning current is applied to batteries that are deeply discharged and have a terminal voltage less than 60% of the constant voltage level. The conditioning current is 5% of the HCP programmable constant current level. Once the battery terminal voltage exceeds the conditioning current threshold, the full constant current level is applied (unless charging current is limited by one of the other charger control loops).

**CHARGE TERMINATION MODE**

To increase system battery life and avoid float charging, the LX2206 turns off the pass element once the battery has been fully charged. The charge termination state occurs at the end of constant voltage mode. The termination current is set by the value of the resistor connected to the HCP programming pin. The STAT pin changes state when charging is completed.

**TOP OFF CHARGE MODE**

Once the charger has completed a charge cycle, if power remains applied, the LX2206 enters a Voltage Monitoring mode. In this mode the LX2206 monitors the battery terminal voltage and applies a top off charge if the battery voltage drops below the top of threshold.

**ADAPTER OR USB SELECTION**

The LX2206 supports battery charging from a system that provides adapter power or USB power using the same external connector. Figure 1 shows one example of a system using a special USB adapter cable to determine whether the power source is USB or Wall Adapter. Similarly, if the system processor senses the absence of USB data, it can logically set the H/L logic level high to allow a higher charge current to be used.

**USB CHARGE MODE AND CURRENT LIMIT**

The LX2206 is fully compliant with, and supports, the USB specifications – the Low Power Peripheral (100mA) and High Power Peripherals (500mA). USB current levels can be set using the appropriate values for the HCP and LCP programming resistors. H/L logic input selects USB high/low charge currents. When the SD pin is pulled high, the USB input enters Suspend mode and will not present a load to the IN pin.

**DCOK**

The IN input is monitored and DCOK is set to a logic low to report the presence of the power source with sufficient voltage to charge the battery. The DCOK threshold is the larger of the UVLO threshold or the battery voltage.

**PROTECTION FEATURES**

**Conditioning Current Mode** – If the battery terminal voltage is less than 2.7V, the battery charger will reduce the charge current to 5%. This also protects the appliance from overheating by trying to drive the full charging current into a short circuited battery.

**Under Voltage Lockout** – The charge cycle will not start until the IN voltage rises above 3.8V. Hysteresis helps alleviate chattering on and off.

**Thermal Control loop** – If the power dissipation of the charger becomes excessive, the charge current will be reduced to prevent the die temperature from getting above 140°C. This does not cause the charge cycle to stop.

**Reverse current blocking** – If IN input is grounded, current will not flow from the BAT pin through the charger. No external blocking diode is required on the input.

**Sleep Mode** – If the SD pin is a logic high, the charger enters a sleep mode where a very low quiescent current prevents drain from the battery.

**APPLICATION NOTE**
**LAYOUT**

In the layout of the Printed Circuit Board (PCB) it is important to provide a solid path from the IC power and ground pins to the power and ground planes of the PCB to provide a good conduction path for heat. This insures the LX2206 stays cool and can provide the maximum charge current to minimize the time required to charge the battery.

For stability purposes and to reduce voltage switching transients it is important to place capacitors close to the IN and BAT pins. A 10µF capacitor (X5R or X7R dielectric) is recommended.

**CURRENT PROGRAMMING RESISTORS**

The LX2206 has two programming resistors to control the battery charging current during the constant current charging mode of the battery charging cycle. When the H/L pin is high (selecting the High Current charging mode), the charge current is determined by the value of the HCP programming resistor. The maximum charge current is determined by the programming current at either the HCP or LCP programming pins (depending on the state of H/L); the range of each of these channels is identical. The programming current is the HCP or LCP pin voltage (typically 1.25V) divided by the value of the programming resistor. For example, the HCP current with a 110K resistor to GND is:

$$I_{HCP} = \frac{1.25}{R_{HCP}} = \frac{1.25}{110k} = 11.4\mu A$$

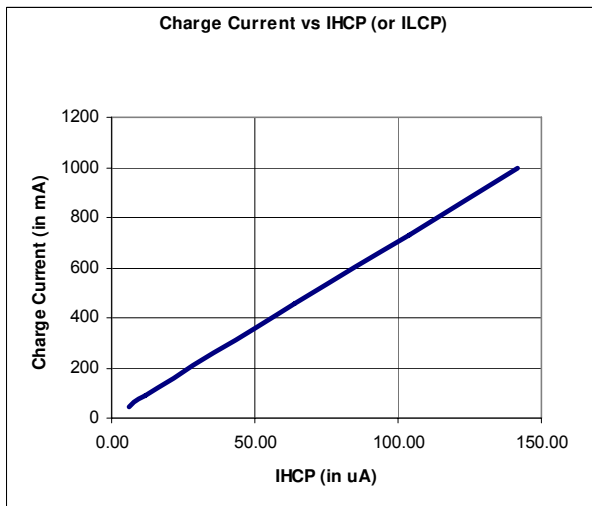

Using the table below it can be seen that for a programming current value of 11.4µA, the corresponding maximum charge current is 92mA.

The termination current determines the point at which the charge cycle is terminated and the battery is determined to be fully charged. The termination current is determined by the value of the HCP programming current as determined by the HCP programming resistor. For a value of IHCP = 11.4µA (as was used in the previous example), the termination current from the chart below can be seen to be 9mA.

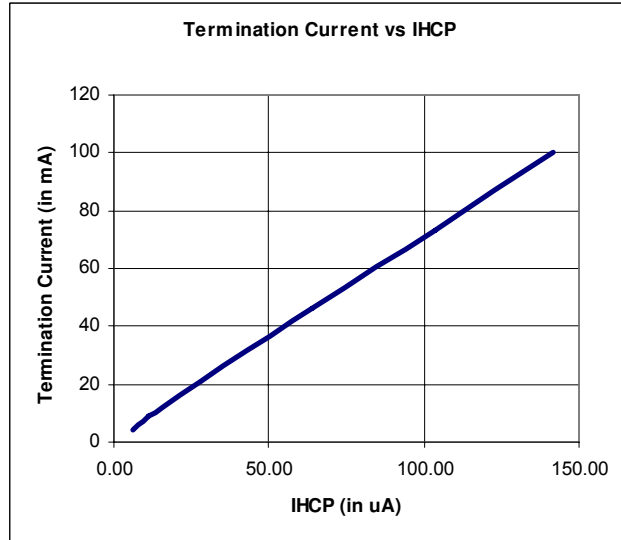

The termination current is always roughly 10% of the maximum charge current set by the HCP resistor.



**APPLICATION NOTE**
**BATTERY TEMPERATURE MONITOR**

The LX2206 has an input to monitor the battery temperature during battery charging; this method assumes the battery pack contains a thermistor expressly for this purpose. A typical Lithium ion battery should only be charged from a range of 0°C to 60°C. For this calculation, a Vishay NTHS0402N01N1003J Thermistor was used. This thermistor is 327KΩ at 0°C, 100KΩ at 25°C and 24.9KΩ at 60°C. The thermistor must be biased with a Thevenin voltage source and series resistance to achieve the proper thresholds. A fixed value resistor is added in series with the thermistor to prevent it from becoming too low an impedance at high temperatures and causing the TMP input to default to off.

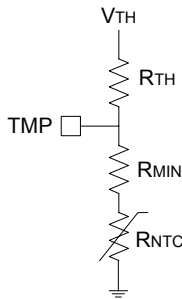

Using a value of  $R_{MIN}$  that is equal to the thermistor temperature at 60°C works well; therefore, for this example, set the value of  $R_{MIN}$  to 24.9K. This has the effect of adding 24.9K to the thermistor resistance values so it becomes 352KΩ at 0°C, 125KΩ at 25°C and 49.8KΩ at 60°C.

The equations for  $R_{TH}$  and  $V_{TH}$  are:

$$\frac{V_{TH}}{V_{IN}} = \frac{0.29 \times 0.74 \times (R_{T=0C} - R_{T=60C})}{(0.29 \times R_{T=0C}) - (0.74 \times R_{T=60C})} = K = 0.99$$

$$R_{TH} = \left( \frac{K}{0.74} - 1 \right) \times R_{T=0C} = 121K$$

Where R at temperature is the sum of the thermistor plus  $R_{MIN}$ .

To finish the design it is necessary to create the Thevenin Voltage and resistance using a voltage divider from the input pin (IN).

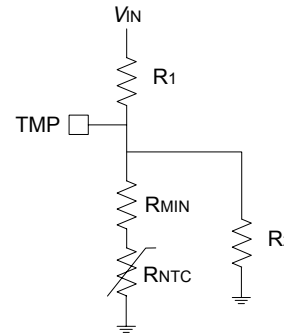

The values of  $R_1$  and  $R_2$  can be calculated as:

$$R_1 = \frac{R_{TH}}{K} = 122K$$

$$R_2 = \frac{R_1 \times R_{TH}}{R_1 - R_{TH}} = 14,800K$$

In this case, it is not necessary to use  $R_2$ , because the value is so large it is insignificant. In this case,  $R_1 = R_{TH}$ .

**APPLICATION NOTE**

The final circuit for this example is:

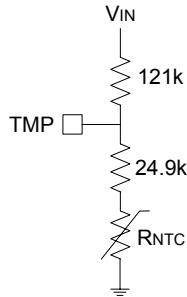

The TMP voltages with this circuit are:

TEMP (°C)	RNTC	VTMP (% VIN)
-20	971k	89%
0	327k	74%
25	100k	51%
60	24.9k	29%
80	12.6k	24%

**POWER STATUS INDICATORS**

The STAT pin is designed to source or sink current. LEDs can be configured to indicate charging or battery full. The battery full indicator can be connected to DCOK rather than GND to insure it is off when the input power is removed and the STAT pin and DCOK pin go to a high impedance state.

Conditions	STAT
Charge in process	Low
Charge completed	High
Input power removed	Hi Z

**INPUT POWER SOURCE DETECTION**

In order to detect when the input power source has been removed, the LX2206 requires that a small current (up to 200uA) momentarily flow out of the IN pin (in the reverse direction). Once detected, the reverse IN current is shut off (the IN pin becomes a very high impedance until an input power source is later reapplied). In most applications, there is sufficient loading on the IN pin from external circuitry to accomplish this, which includes the “Full” and/or “Power On” LED loads and the TFB resistor string. If there is no external load on the IN pin, then it is recommended to provide a 15k resistor from IN to GND as shown below.

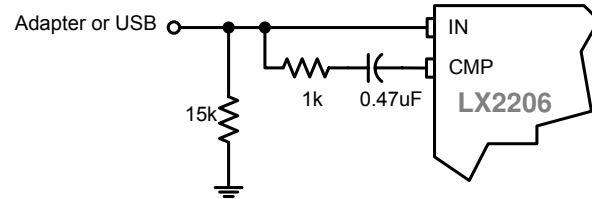

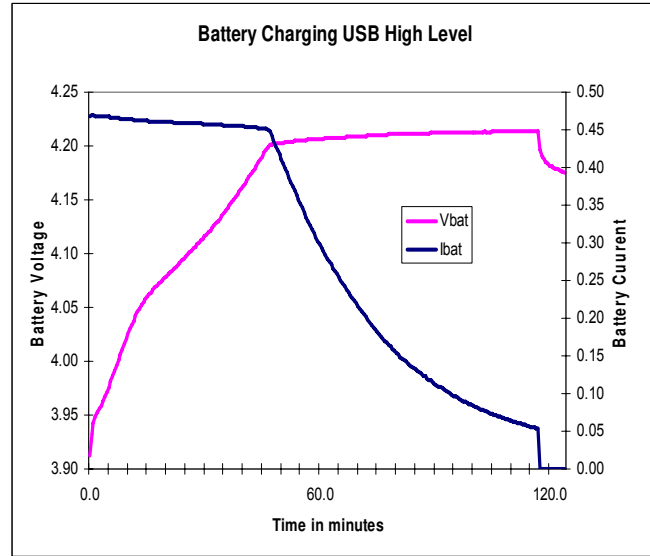
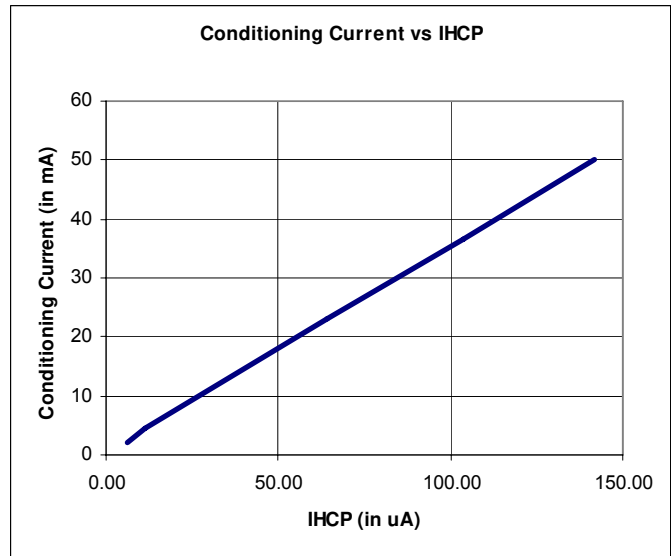
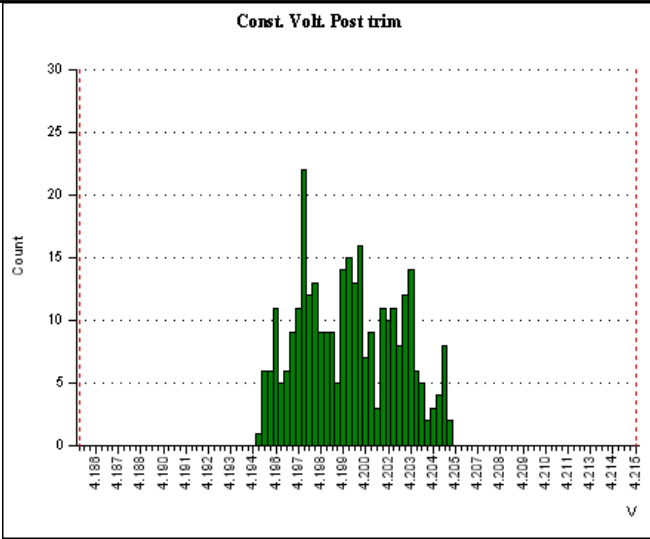
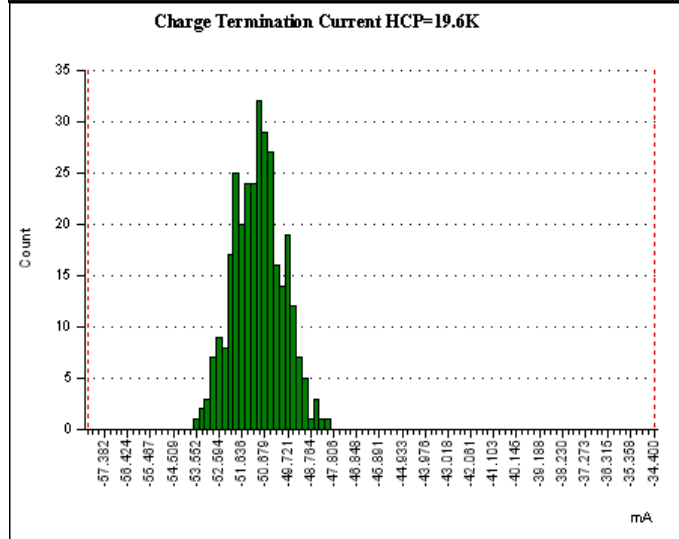
**CHARGING PROFILE**

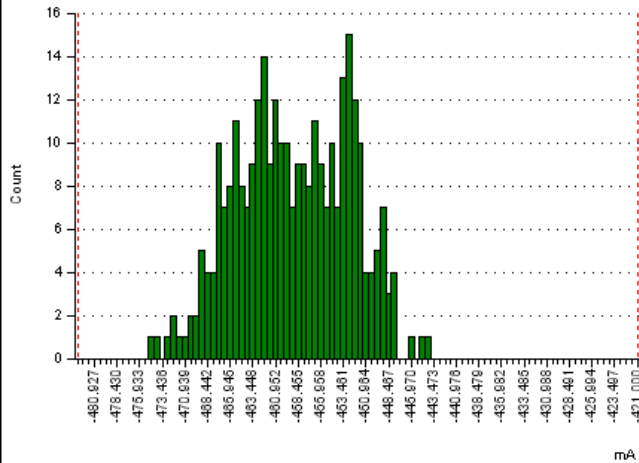
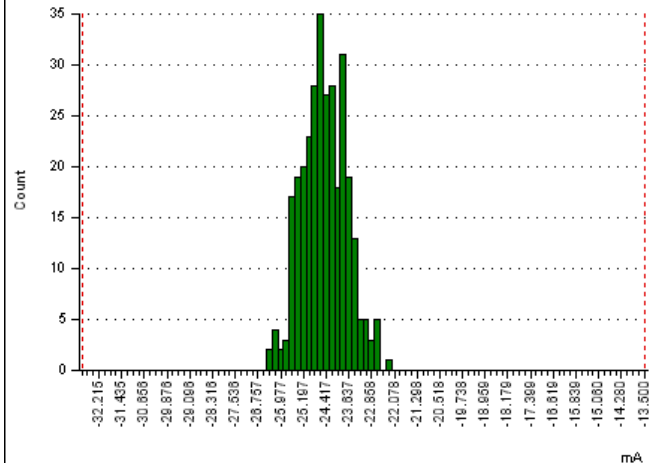
**CONDITIONING CURRENT**

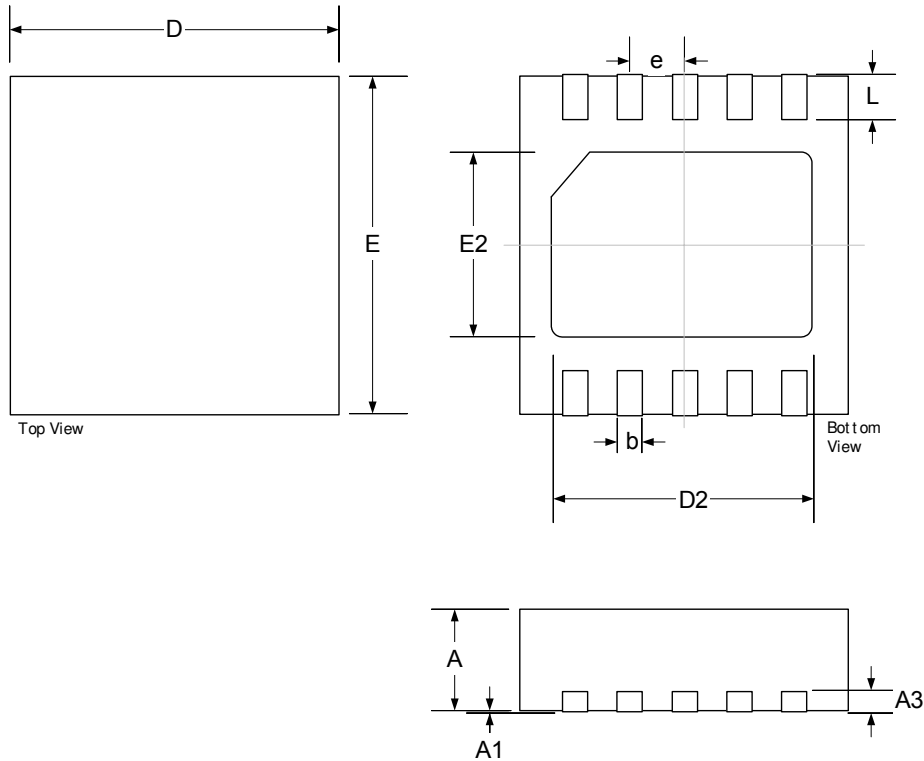
**FLOAT VOLTAGE**

**TERMINATION CURRENT**

**CONSTANT CURRENT**
**Batt Chg Current High Curr Mode HCP=19.6K**

**CONDITIONING CURRENT**
**Conditioning Current HCP=19.6K**

**PACKAGE DIMENSIONS**
**LD** 10-Pin Plastic MLP Dual Exposed Pad

Dim	MILLIMETERS		INCHES	
	MIN	MAX	MIN	MAX
A	0.80	1.00	0.0315	0.0394
A1	0	0.05	0	0.0019
A3	0.20 REF		0.0079 REF	
b	0.18	0.30	0.0071	0.0118
D	3.00 BSC		0.1181 BSC	
D2	2.23	2.48	0.0878	0.0976
e	0.50 BSC		0.0197 BSC	
E	3.00 BSC		0.1181 BSC	
E2	1.49	1.74	0.0587	0.0685
L	0.30	0.50	0.0071	0.0197

**Note:**

- Dimensions do not include mold flash or protrusions; these shall not exceed 0.155mm(.006") on any side. Lead dimension shall not include solder coverage.



**Microsemi**<sup>®</sup>

**LX2206**

**Dual Level Lithium Ion Battery Charger**

**PRODUCTION DATA SHEET**

**NOTES**

PRODUCTION DATA – Information contained in this document is proprietary to Microsemi and is current as of publication date. This document may not be modified in any way without the express written consent of Microsemi. Product processing does not necessarily include testing of all parameters. Microsemi reserves the right to change the configuration and performance of the product and to discontinue product at any time.