

LOC		DIST		REVISIONS			
P	LTR	DESCRIPTION	DATE	DWN	APVD		
A		REVISED PER ECR-12-013323	09AUG12	KH	TM		

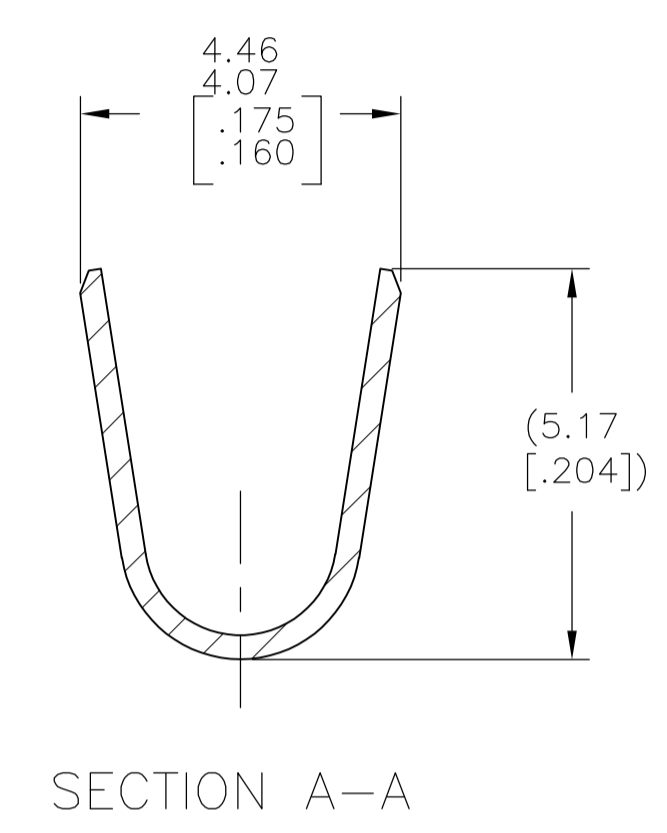

1 WIRE RANGE: 12-10 AWG  
 WIRE INSULATION DIAMETER: 5.08 [.200] MAX.  
 LIMITED BY THE CONNECTOR HOUSING CAVITY

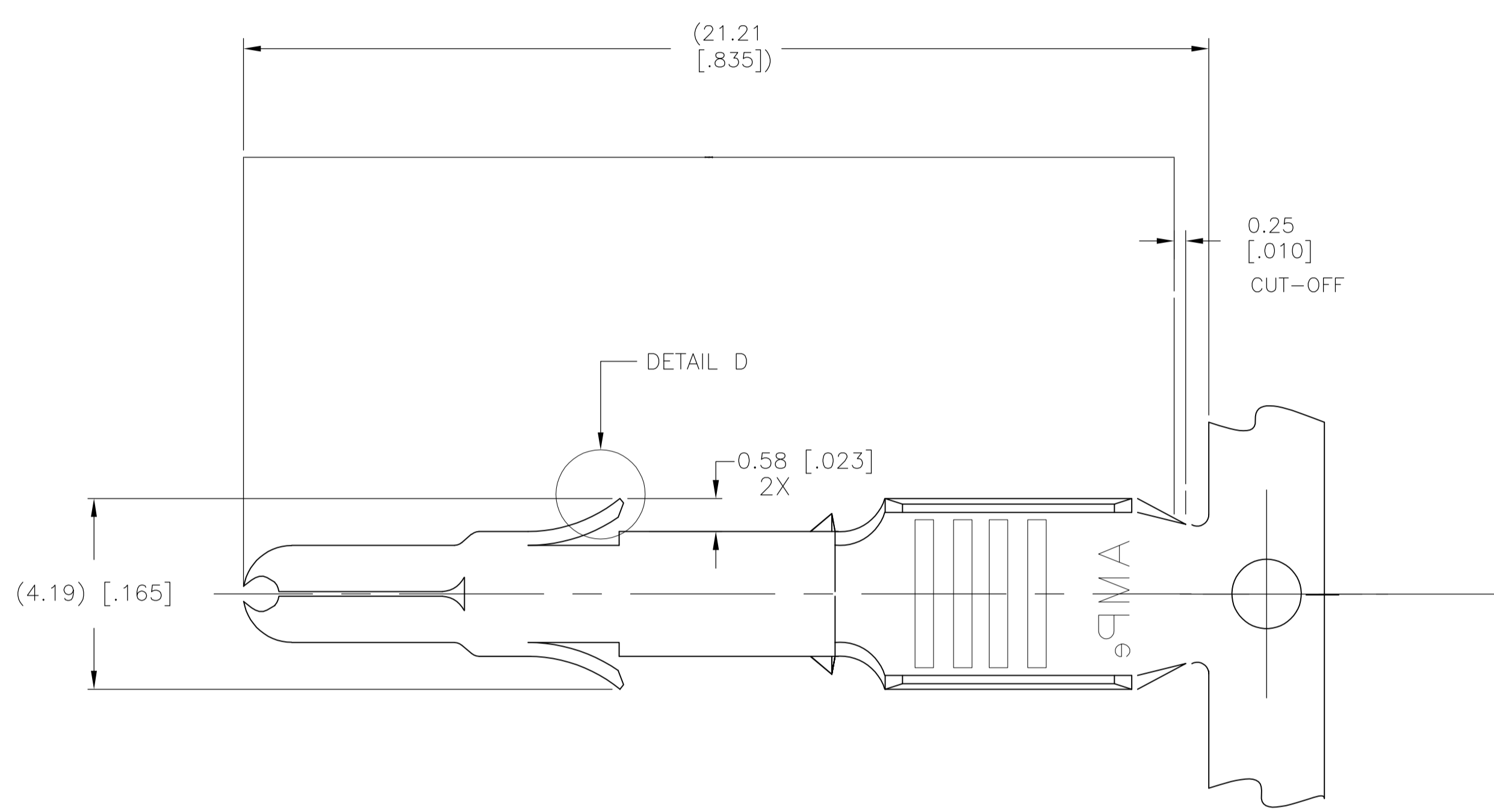
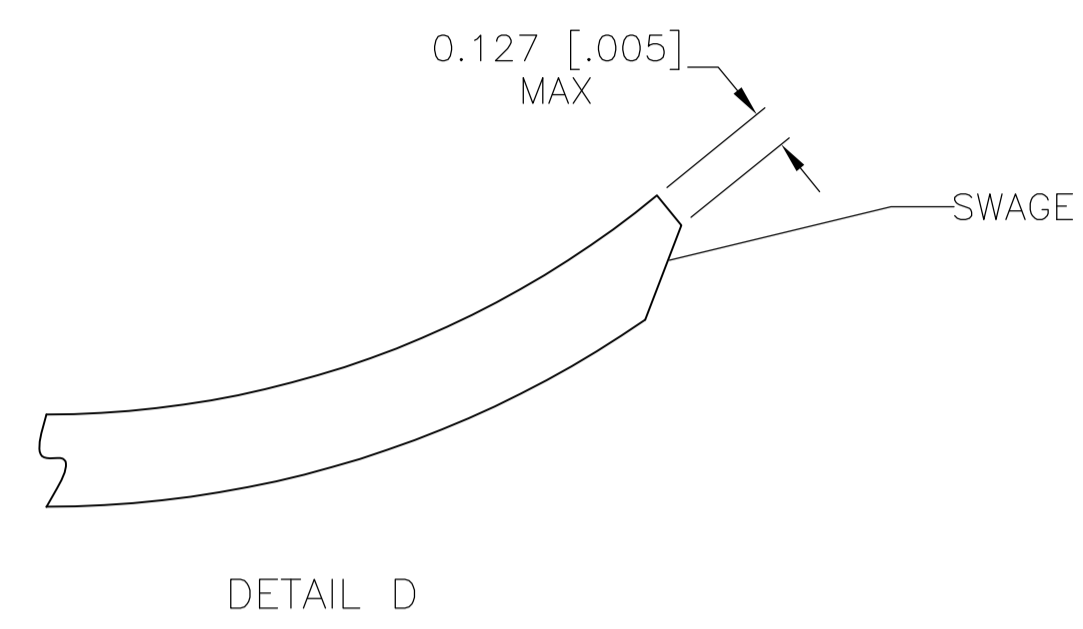
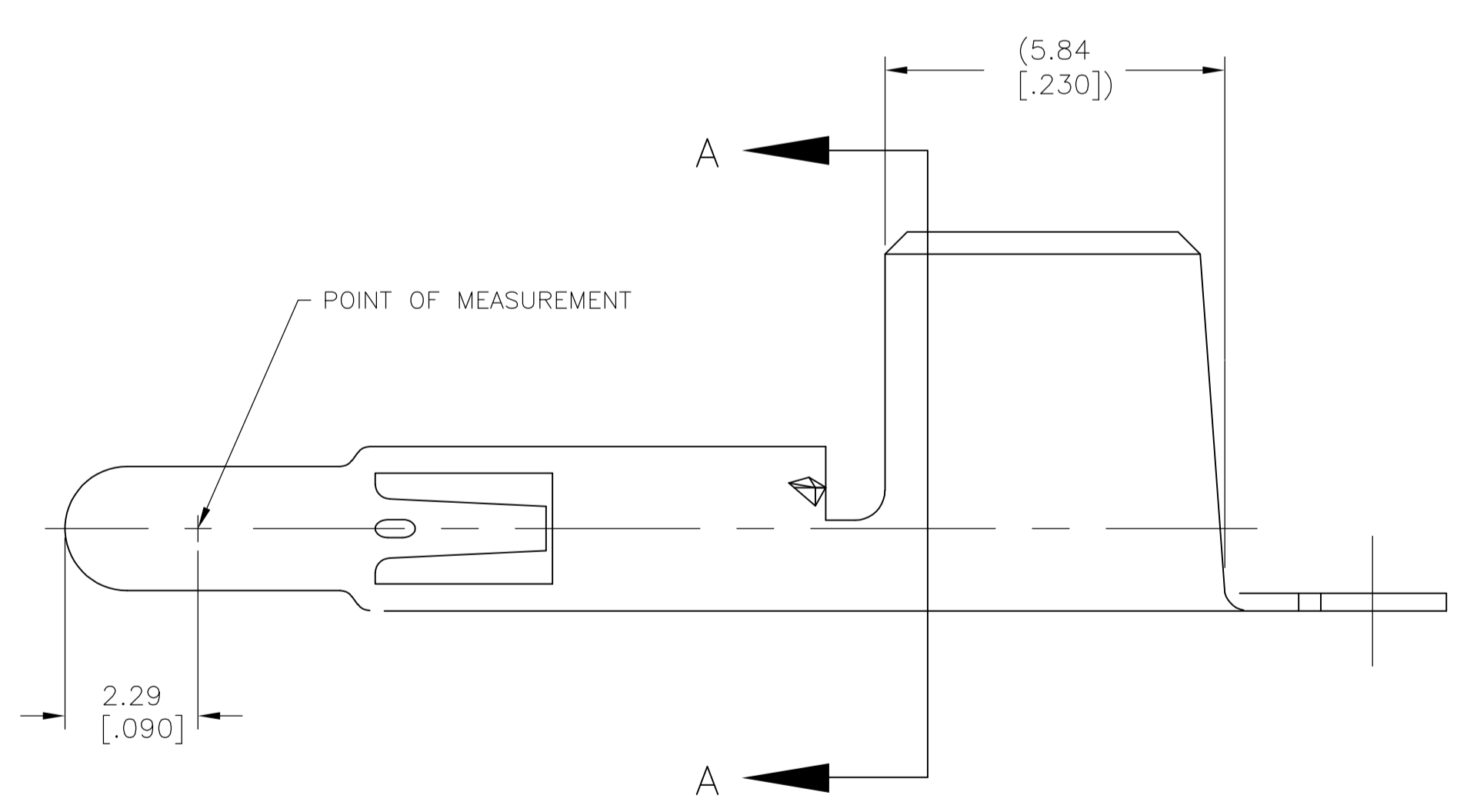
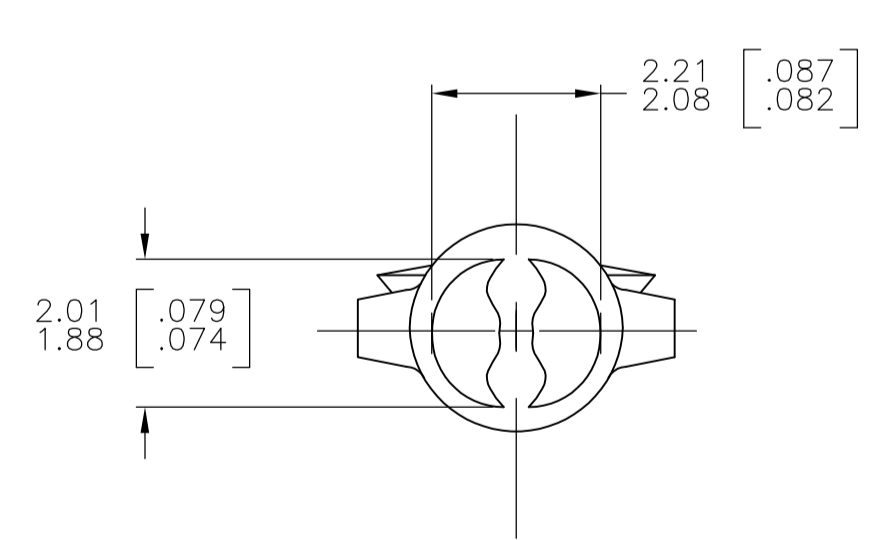

FINISH	MATERIAL	PART NUMBER
PRE-TIN	.012 COPPER ALLOY	1586096-1

THIS DRAWING IS A CONTROLLED DOCUMENT.		DIN S. HOOVER 25-MAR-2003		TE Connectivity	
DIMENSIONS: mm [INCHES]		CHK S. RIDGILL 25-MAR-2003			
TOLERANCES UNLESS OTHERWISE SPECIFIED:		APVD S. RIDGILL 25-MAR-2003		NAME	
0 PLC ±		PRODUCT SPEC		SPLIT PIN, ENHANCED CURRENT UNIVERSAL MATE-N-LOK™	
1 PLC ±		APPLICATION SPEC		SIZE	
2 PLC ± 0.13 [.005]		WEIGHT		CAGE CODE	
3 PLC ±		A1 00779		DRAWING NO	
4 PLC ±		CUSTOMER DRAWING		RESTRICTED TO	
ANGLES ±		SCALE 10:1		SHEET 1 OF 1	
FINISH		SCALE 10:1		REV A	