

Heat Sink SCR IGBT Assemblies

Wakefield-Vette compression pack heat sink and clamp systems provide customers with the complete system solution for proper installation and heat dissipation for high-power compression pack semiconductors. These high-quality mounting clamp assemblies are the industry standard for mounting, compressing, and clamping press-pack SCR, thyristors, rectifiers, and other high power disc packaged devices. Devices of these styles are most commonly found in power distribution equipment, industrial controls, transportation systems, and power supply and conversion systems.



A clamp system consists of a crossbar and a spring assembly. The crossbar is a steel bar with two threaded rods installed in it. The rods are generally knurled and cold rolled into the bar to ensure proper fit. The cross bar assembly is covered in an epoxy coating which acts as an electrical insulator to ensure the devices are properly grounded. The crossbar is installed through the center web of the heat sink and sits in a channel surrounded by fins needed for thermal performance.



On the back of the heat sink, a puck style device is installed and then the spring assembly is installed in the threaded rods of the crossbar. By tightening the nuts on the spring assembly, a compression force is applied to the center of the puck. Each spring assembly has a force gauge integrated into it to ensure ease of assembly and consistency of force applied to the many devices used in a system.

The cross bar assembly is available in various lengths to meet the various needs of the industry. All components for device mounting are available separately for all standard compression requirements from 800 lbs. to 16,000 lbs.



PRECISION COMPRESSION MOUNTING CLAMP SYSTEMS

Wakefield-Vette Engineering compression pack heat sinks and clamp systems provide electrical and industrial equipment manufacturers with complete system solutions for proper installation and heat dissipation for high-power compression pack semiconductor. All components for device mounting and cooling are available separately for all standard compression requirements from 800 lbs (362.9 kg) to 16,000 lbs (7,257.5 kg) force in both natural and forced convection applications.

Clamp Assembly Series	Maximum Clamping Force Force Range	Maximum Diameter (Ref) Power Disc Device	Crossbar Stud Centerline to Centerline Dimension
130 Series	800 lbs (362.9 kg) - 2,000 lbs (907.2 kg)	2.25 in. (57.2 mm)	2.750 in. (69.9 mm) Ref
139 Series	3,000 lbs (1,360.8 kg) and 5,000 lbs (2,268.0 kg)	3.50 in. (88.9 mm)	4.000 in. (101.6 mm) Ref
143 Series	1,000 lbs (453.6 kg) - 6,000 lbs (2,721.6 kg)	3.50 in. (88.9 mm)	4.000 in. (101.6 mm) Ref
144 Series	1,000 lbs (453.6 kg) - 6,000 lbs (2,721.6 kg)	4.00 in. (101.6 mm)	4.625 in. (117.5 mm) Ref
145 Series	2,000 lbs (907.2 kg) - 10,000 lbs (4,535.9 kg)	4.50 in. (114.3 mm)	5.500 in. (139.7 mm) Ref
146 Series	8,000 lbs (3,628.8 kg) - 16,000 lbs (7,257.5 kg)	5.25 in. (133.4 mm)	6.000 in. (152.4 mm) Ref
131/132/133 Series	High-Performance Press Pack Heat Sinks		

These high-quality mounting clamp assemblies are the worldwide standard for mounting, compression, and clamping press-pack SCR, thyristor, and other high power disc packaged devices utilized in power distribution equipment, industrial controls, transportation systems, and power supply and conversion systems.

Clamp assemblies will accommodate devices with overall case diameters to 5.25 in. (133.4 mm) maximum. Vertical device mounting space available for assemblies is determined by selecting an appropriate series crossbar by length which, when a series spring assembly is selected (based on maximum clamping force required), will provide the necessary vertical clearance space. For the 130 and 139 Series, this determination is made by subtracting the chosen spring assembly "Z" dimension (refer to dimensional tables) from the crossbar assembly "X" dimension minimum and maximum values, to calculate the available device mounting space clearance for the particular assembly combination. Spring assembly "Z" dimension is the dimension measured from the spring assembly device mounting surface to the spring assembly top surface. Some series have fixed dimensions for alpha characters. All spring assemblies are designed with a force indicator gauge.

Max SCR DIA	Clamp Series	Force Range	Extrusion Profile	
101.6 mm	ALL	800 - 16000 LBS	XX7151	
84 mm	ALL	800 - 16000 LBS	XX6351	
63 mm	ALL	800 - 16000 LBS	XX5735	
	144	800 - 6000 LBS	XX5360	
	143	800 - 6000 LBS	XX10239	
	144	800 - 6000 LBS	O16235	
	144	800 - 6000 LBS	O14442	
	143	800 - 6000 LBS	XX3529	
	143	800 - 6000 LBS	XX5730	
	143	800 - 6000 LBS	O14191	
	143	800 - 6000 LBS	XX3849	
50 mm	143	800 - 6000 LBS	XX5733	
	143	800 - 6000 LBS	XX3559-2	
	143	800 - 6000 LBS	XX5736	
	143	800 - 6000 LBS	XX3561-2	
	143	800 - 6000 LBS	XX5732	
	143	800 - 6000 LBS	XX5731	
	143	800 - 6000 LBS	XX3560-2	
	143	800 - 6000 LBS	O13450	
	143	800 - 6000 LBS	XX4554	
	143	800 - 6000 LBS	XX5331	
	143	800 - 6000 LBS	O03537	
	143	800 - 6000 LBS	XX5306	
	40 mm	143	800 - 6000 LBS	O14779

COMPRESSION MOUNTING CLAMP ASSEMBLIES FOR SEMICONDUCTORS TO 2.25 IN. (57.2 MM) DIAMETER

130 SERIES

130 SERIES SPRING ASSEMBLY				
Model No.	No. of Leaves	"Z" Dim. in. (mm)	Max Force lb. (kg)	Weight lbs. (gms)
130-1	2	0.90 (22.9)	2,000 (907.2)	0.331 (150.14)
130-2	2	0.50 (12.7)	800 (362.8)	0.19 (86.18)
130-3	3	0.61 (15.5)	1,200 (544.3)	0.219 (99.34)
130-4	4	0.72 (18.3)	1,600 (727.8)	0.333 (151.05)
130-5	5	0.83 (21.1)	2,000 (907.2)	0.408 (185.07)

NOTES:

1. Spring assemblies are stainless steel leaves with a force indicator gauge, except the lowest cost Type 130-1 spring assembly manufactured from automotive grade stainless steel.

Order Guide: Order Crossbar and Spring Assembly separately by type number from table.
Dimensions: in. (mm) lb. (kg)

COMPRESSION MOUNTING CLAMP ASSEMBLIES FOR SEMICONDUCTORS TO 3.50 IN. (88.9 MM) DIAMETER



139 SERIES

139 SERIES CROSSBAR 3,000 lb - 5,000 lb, (1,360.8 kg - 2,268.0 kg), Crossbar Device Mounting, Surface to Spring Assembly, Top Surface Dimension							
139-3 SERIES CROSSBAR - 3,000 LB (1,360.8)				139-5 SERIES CROSSBAR - 5,000 LB (2,268.0)			
Model No.	"X" Dimension		Weight lbs. (grams)	Model No.	"X" Dimension		Weight lbs. (grams)
	Min in. (mm)	Max in. (mm)			Min in. (mm)	Max in. (mm)	
139-3A	1.52 (38.6)	1.89 (48.0)	0.689 (312.52)	139-5A	1.52 (38.6)	1.89 (48.0)	0.94 (426.38)
139-3B	1.83 (46.5)	2.21 (56.1)	0.7 (317.51)	139-5B	1.83 (46.5)	2.21 (56.1)	0.96 (435.45)
139-3C	2.14 (54.4)	2.52 (64.0)	0.706 (320.24)	139-5C	2.14 (54.4)	2.52 (64.0)	0.98 (444.52)
139-3D	2.45 (62.2)	2.83 (71.9)	0.721 (327.04)	139-5D	2.45 (62.2)	2.83 (71.9)	1.01 (458.13)
139-3E	2.77 (70.4)	3.14 (79.8)	0.732 (332.03)	139-5E	2.77 (70.4)	3.14 (79.8)	1.02 (462.66)
139-3F	3.08 (78.2)	3.45 (87.6)	0.741 (336.11)	139-5F	3.08 (78.2)	3.45 (87.6)	1.033 (468.56)
139-3G	3.39 (86.1)	3.77 (95.8)	0.762 (345.64)	139-5G	3.39 (86.1)	3.77 (95.8)	1.053 (477.63)
139-3H	3.70 (94.0)	4.08 (103.6)	0.773 (350.63)	139-5H	3.70 (94.0)	4.08 (103.6)	1.074 (487.64)
130-3J	4.01 (101.9)	4.39 (111.5)	0.784 (355.62)	139-5J	4.33 (101.9)	4.39 (111.5)	1.064 (482.62)
139-3K	4.33 (110.0)	4.70 (119.4)	0.79 (358.34)	139-5K	4.33 (110.0)	4.70 (119.4)	1.075 (487.61)
139-3L	4.64 (117.9)	5.01 (127.3)	0.793 (359.70)	139-5L	4.64 (117.9)	5.01 (127.3)	1.088 (493.51)
139-3M	4.95 (125.7)	5.33 (135.4)	0.796 (361.06)	139-5M	4.95 (125.7)	5.33 (135.4)	1.102 (499.86)
139-3N	5.26 (133.6)	5.64 (143.3)	0.832 (377.39)	139-5N	5.26 (133.6)	5.64 (143.3)	1.11 (503.49)
139-3P	5.57 (141.5)	5.95 (151.1)	0.838 (380.11)	139-5P	5.57 (141.5)	5.95 (151.1)	1.171 (531.16)

CROSSBAR HEIGHT AND WIDTH		
Series Number	Height "A" Reference in. (mm)	Width "B" Reference in. (mm)
139-3	0.72 (18.3)	0.95 (24.1)
139-5	1.02 (25.9)	0.83 (21.1)

139 SERIES SPRING ASSEMBLY			
Model Number	Number of Leaves	"Z" Dimension in. (mm)	Maximum Force lb. (kg)
139-1	1	0.87(22.1)	3,000 (1,360.8)
139-2	2	1.25(31.8)	5,000 (2,268.0)



130 SERIES

COMPRESSION MOUNTING CLAMP ASSEMBLIES FOR SEMICONDUCTORS TO 2.25 IN. (57.2 MM) DIAMETER

130 SERIES CROSSBAR 800 lb - 2,000 lb (362.8 kg - 907.2 kg)			
Crossbar Device Mounting, Surface to Spring Assembly Top Surface Dimension			
Model No.	"X" Dimension		Weight lbs. (grams)
	Min. in. (mm)	Max. in. (mm)	
130-A	1.74 (44.2)	2.12 (53.8)	0.4 (181.44)
130-B	2.05 (52.1)	2.43 (61.7)	0.418 (189.60)
130-C	2.36 (59.9)	2.74 (69.6)	0.427 (193.68)
130-D	2.67 (67.8)	3.05 (77.5)	0.437 (198.22)
130-E	2.98 (75.7)	3.36 (85.3)	0.447 (202.76)
130-F	3.29 (83.6)	3.67 (93.2)	0.461 (209.11)
130-G	3.60 (91.4)	3.98 (101.1)	0.476 (215.91)
130-H	3.91 (99.3)	4.29 (109.0)	0.486 (220.45)
130-J	4.22 (107.2)	4.60 (116.8)	0.497 (225.44)
130-K	4.53 (115.1)	4.91 (124.7)	0.51 (231.33)
130-L	4.34 (122.9)	5.22 (132.6)	0.52 (235.87)
130-M	5.15 (130.8)	5.53 (140.5)	0.534 (242.22)
130-N	5.46 (138.7)	5.84 (147.3)	0.544 (246.75)
130-P	5.77 (146.6)	6.15 (156.2)	0.559 (253.56)

MECHANICAL DIMENSIONS

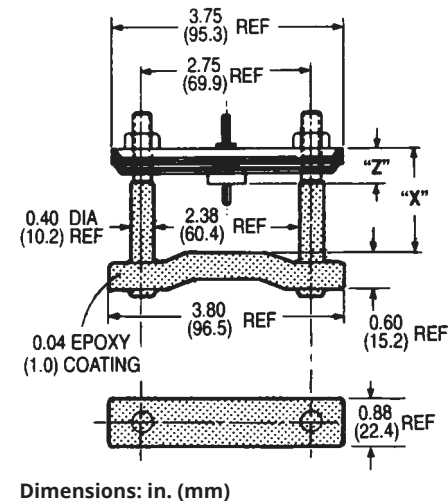

MECHANICAL DIMENSIONS

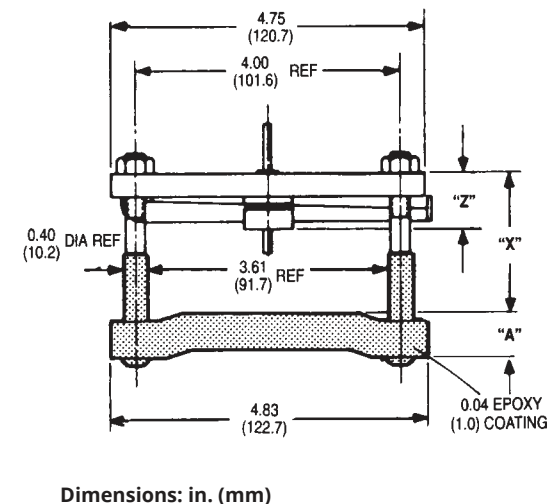

Order Guide: Order Crossbar and Spring Assembly separately by type number from table.
Dimensions: in. (mm) lb. (kg)

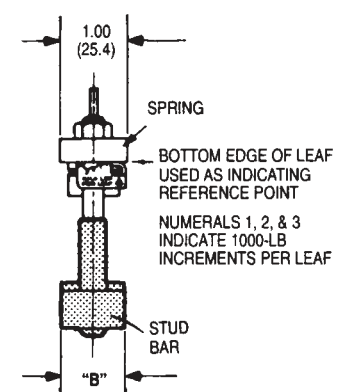

PRECISION COMPRESSION MOUNTING CLAMP SYSTEMS

143 SERIES

COMPRESSION MOUNTING CLAMP ASSEMBLIES FOR SEMICONDUCTORS TO 3.50 IN. (88.9 MM) DIAMETER

143 SERIES CROSSBAR 2,000 lb - 6,000 lb (907.2 kg - 2,721.6 kg)				
Crossbar Device Mounting, Surface to Spring Assembly, Top Surface Dimension				
Model No.	"X" Dimension		Overall Height "H" in. (mm)	Weight lbs. (grams)
	Min in. (mm)	Max in. (mm)		
143-A	1.30 (33.0)	1.80 (45.7)	4.68 (118.9)	1,100 (498.95)
143-B	1.86 (45.7)	2.30 (58.4)	5.18 (131.6)	1,125 (510.29)
143-C	2.30 (58.4)	2.80 (71.1)	5.68 (144.3)	1,150 (521.63)
143-D	2.80 (71.1)	3.30 (83.8)	6.18 (157.0)	1,175 (532.97)
143-E	3.30 (83.8)	3.80 (96.5)	6.68 (169.7)	1,200 (544.31)
143-F	3.80 (96.5)	4.30 (109.2)	7.18 (182.4)	1,225 (555.65)
143-G	4.30 (109.2)	4.80 (121.9)	1.68 (195.1)	1,250 (566.99)
143-H	4.80 (121.9)	5.30 (134.6)	8.18 (207.8)	1,275 (578.33)
143-J	5.30 (134.6)	5.80 (147.3)	8.68 (220.5)	1,300 (589.67)
143-K	5.80 (147.3)	6.30 (160.0)	9.18 (233.2)	1,325 (601.00)
143-L	6.30 (160.0)	6.80 (172.7)	9.68 (245.9)	1,350 (612.35)

143 SERIES SPRING ASSEMBLY			
Model Number	Number of Leaves	Max. Clamping Force lb. (kg)	Weight lb. (grams)
143-2	2	6,000 (2,721.6)	0.813 (368.77)

Order Guide:
Order Crossbar and Spring Assembly separately by type number from table.

Dimensions:
in. (mm)
lb. (kg)

MECHANICAL DIMENSIONS

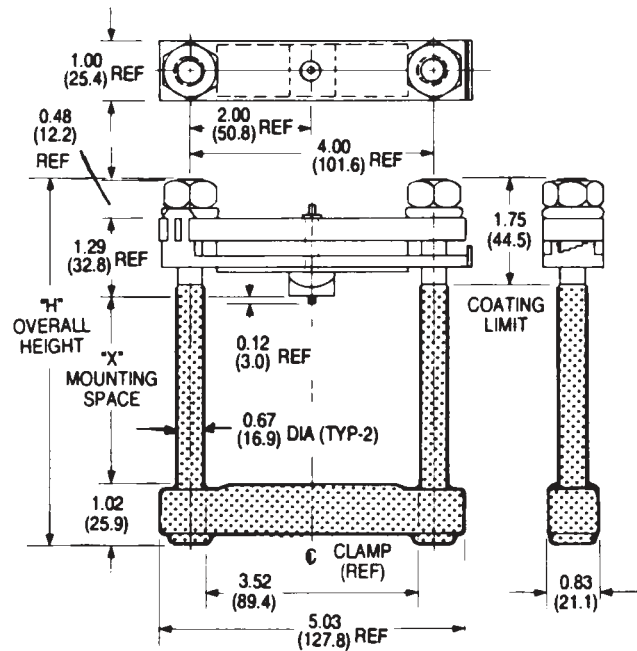

Dimensions: in. (mm)

COMPRESSION MOUNTING CLAMP ASSEMBLIES FOR SEMICONDUCTORS TO 4.00 IN. (101.6 MM) DIAMETER

144 SERIES

144 SERIES CROSSBAR 1,000 lb - 6,000 lb (453.6 kg - 2,721.6 kg)			
Crossbar Device Mounting, Surface to Spring Assembly Top Surface Dimension			
Model No.	"X" Dimension		Weight lbs. (grams)
	Min in. (mm)	Max in. (mm)	
144-A	1.50 (38.1)	2.00 (50.8)	1,231 (558.37)
144-B	2.00 (50.8)	2.50 (63.5)	1,262 (572.43)
144-C	2.50 (63.5)	3.00 (76.2)	1,285 (582.87)
144-D	3.00 (76.2)	3.50 (88.9)	1,310 (594.21)
144-E	3.50 (88.9)	4.00 (101.6)	1,352 (613.26)

144 SERIES SPRING ASSEMBLY		
Model No.	Clamping Force Range lb. (kg)	Weight lbs. (grams)
144-2	1,000 (453.6) - 6,000 (2,721)	1.772 (803.77)

Order Guide:
Order Crossbar and Spring Assembly separately by type number from table.

Dimensions:
in. (mm)
lb. (kg)

MECHANICAL DIMENSIONS

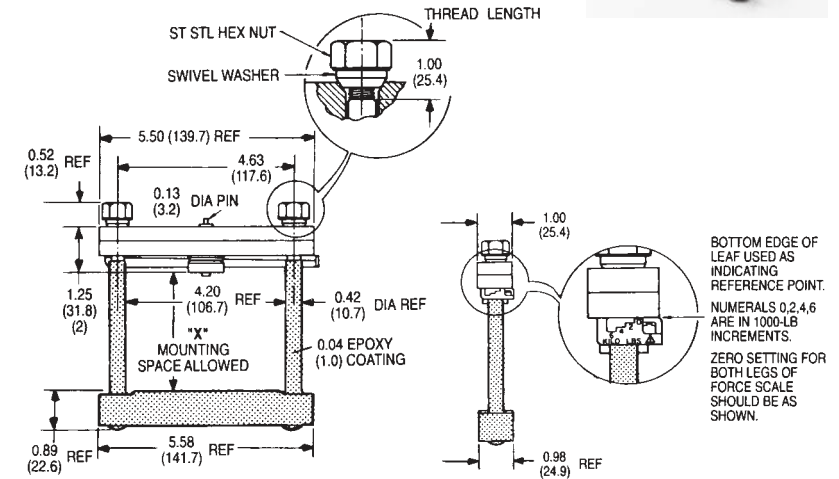

Dimensions: in. (mm)

145 SERIES

COMPRESSION MOUNTING CLAMP ASSEMBLIES FOR SEMICONDUCTORS TO 4.50 IN. (114.3 MM) DIAMETER

145 SERIES CROSSBAR 2,000 lb - 10,000 lb (907.2 kg - 4,535.9 kg)				
Crossbar Device Mounting, Surface to Spring Assembly, Top Surface Dimension				
Model No.	"X" Dimension		Overall Height "H" in. (mm)	Weight lbs. (grams)
	Min in. (mm)	Max in. (mm)		
145-A	1.75 (44.5)	2.50 (63.5)	6.00 (152.4)	3,845 (1744.06)
145-B	2.50 (63.5)	3.25 (82.6)	6.75 (171.5)	3,987 (1808.47)
145-C	3.25 (82.6)	4.00 (101.6)	7.50 (190.5)	4,06 (1841.58)
145-D	4.00 (101.6)	4.75 (120.7)	8.25 (209.6)	4,187 (1899.19)
145-E	4.75 (120.7)	5.50 (139.7)	9.00 (228.6)	4,37 (1982.20)
145-F	5.50 (139.7)	6.25 (158.8)	9.75 (247.7)	4,459 (2022.57)

145 SERIES SPRING ASSEMBLY		
Model No.	Clamping Force Range lb. (kg)	Weight lbs. (grams)
145-2	2,000 (907.2) - 10,000 (4,535.9)	2.01 (911.72)

Order Guide:
Order Crossbar and Spring Assembly separately by type number from table.

Dimensions:
in. (mm)
lb. (kg)

MECHANICAL DIMENSIONS

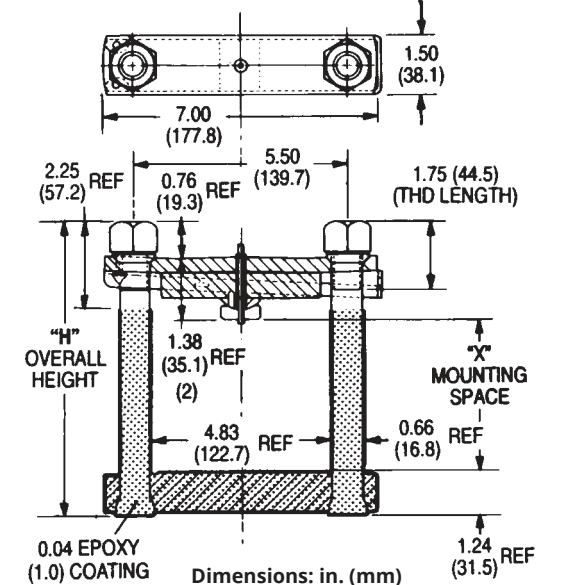

Dimensions: in. (mm)

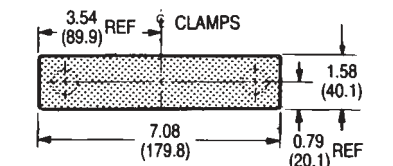

PRECISION COMPRESSION MOUNTING CLAMP SYSTEMS

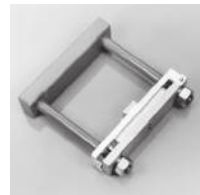

146 SERIES

COMPRESSION MOUNTING CLAMP ASSEMBLIES FOR SEMICONDUCTORS TO 5.25 IN. (133.5 MM) DIAMETER

146 SERIES CROSSBAR
8,000 lb-16,000 lb (3,628.7 kg - 7,257.4 kg)

Crossbar Device Mounting, Surface to Spring Assembly, Top Surface Dimension

Model No.	"X" Dimension		Overall Height "H" in. (mm)	Weight lbs. (grams)
	Min in. (mm)	Max in. (mm)		
146-A	1.54 (39.1)	2.29 (58.2)	5.92 (150.4)	3.813 (1729.55)
146-B	2.29 (58.2)	3.04 (77.2)	6.67 (169.4)	3.938 (1786.25)
146-C	3.04 (77.2)	3.79 (96.3)	7.42 (188.5)	4.063 (1842.95)
146-D	3.79 (96.3)	4.54 (115.3)	8.17 (207.5)	4.188 (1899.64)
146-E	4.54 (115.3)	5.29 (134.4)	8.92 (226.6)	4.313 (1956.34)
146-F	5.29 (134.4)	6.04 (153.4)	9.67 (245.6)	4.438 (2013.04)
146-G	6.04 (153.4)	6.79 (172.5)	10.42 (264.7)	4.563 (2069.74)

146 SERIES SPRING ASSEMBLY

Model Number	Number of Leaves	Clamping Force Range lb. (kg)	Maximum Force lb. (grams)
146-2	2	8,000 (3,628.7) - 16,000 (7,257.5)	2,688 (1,219.26)

Order Guide:
Order Crossbar and Spring Assembly separately by type number from table.

Dimensions:
in. (mm)
lb. (kg)

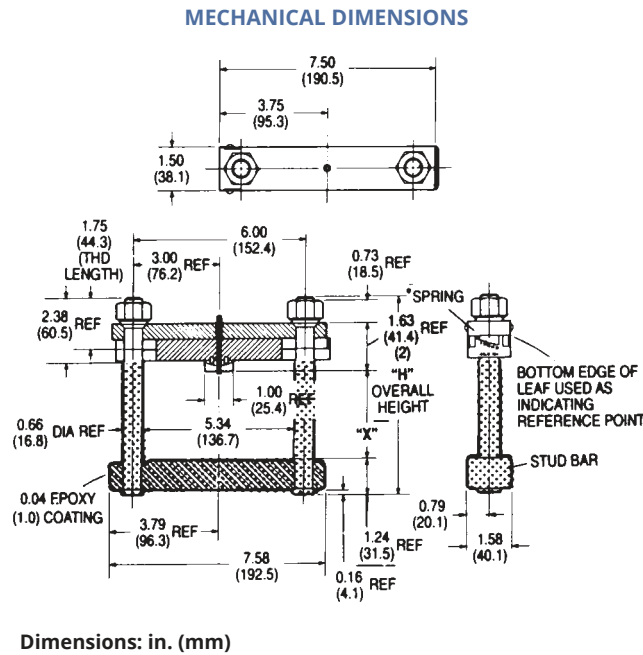

132/133 SERIES HIGH-PERFORMANCE HEAT SINKS FOR COMPRESSION TYPE DEVICES

132 & 133 SERIES

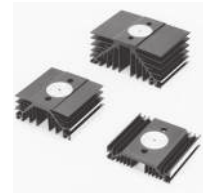

Standard P/N		Width in. (mm)	Nominal Dimensions: ⁽¹⁾ Length "A" in. (mm)	Height in. (mm)	Clamp System Series ⁽⁵⁾	Thermal Performance at Typical Load ⁽²⁾	
Black Anodize ^(4,5)	Gold Iridite					Natural Convection (°C/W) ⁽³⁾	Convection (°C/W) @ 500 LFM
132-4.5B	132-4.5G	5.000 (127.0)	4.500 (114.3)	2.250 (57.2)	130	0.61	0.170
132-10B	132-10G	5.000 (127.0)	10.000 (254.0)	2.250 (57.2)	130	0.38	0.130
132-15.5B	132-15.5G	5.000 (127.0)	15.500 (393.7)	2.250 (57.2)	130	0.28	0.100
132-5-B9	132-5-G9	5.000 (127.0)	5.000 (127.0)	2.250 (57.2)	139	0.61	0.170
132-11-B9	132-11-G9	5.000 (127.0)	11.000 (279.4)	2.250 (57.2)	139	0.37	0.120
133-4.5B	133-4.5G	7.000 (177.8)	4.500 (114.3)	3.125 (79.4)	130	0.37	0.110
133-7.5B	133-7.5G	7.000 (177.8)	7.500 (190.5)	3.125 (79.4)	130	0.28	0.085
133-10B	133-10G	7.000 (177.8)	10.000 (254.0)	3.125 (79.4)	130	0.26	0.082
133-5-B9	133-5-G9	7.000 (177.8)	5.000 (127.0)	3.125 (79.4)	139	0.37	0.110
133-7.5-B9	133-7.5-G9	7.000 (177.8)	7.500 (190.5)	3.125 (79.4)	139	0.28	0.085
133-11-B9	133-11-G9	7.000 (177.8)	11.000 (279.4)	3.125 (79.4)	139	0.24	0.076

Material: Aluminum, Black Anodized
Finish: B = Black Anodized, G = Gold Iridite

132 & 133 SERIES

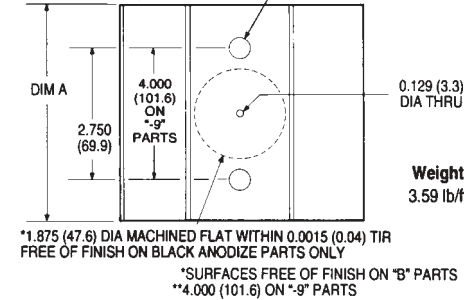
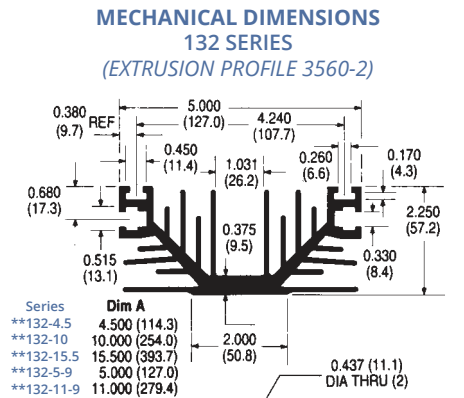
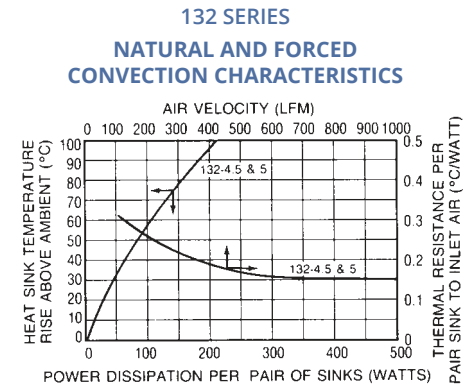

MULTIPLE ASSEMBLY CONFIGURATION

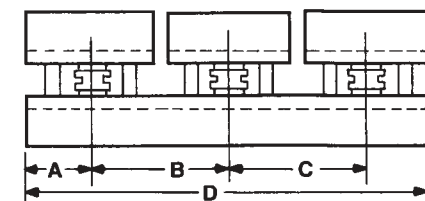

Type	Use with	A	B	C	D
132-4.5	-	-	-	See Fig.132	-
132-10	2 ea 132-4.5	2.25	5.50	-	10.0
132-15.5	3 ea 132-4.5	2.25	5.50	5.50	15.5
133-4.5	-	-	-	See Fig.133	-
133-7.5	-	-	-	See Fig.133	-
133-10	2 ea 133-4.5	2.25	5.50	-	10.0
132-5-9**	-	-	-	See Fig.132	-
132-11-9**	2 ea 132-5-9	2.50	6.00	-	11.00
133-5-9**	-	-	-	See Fig.133	-
133-7.5-9**	-	-	-	See Fig.133	-
133-11-9**	2 ea 133-5-9	2.50	6.00	-	11.00

** -9 indicates heat sinks drilled for 139 clamp.

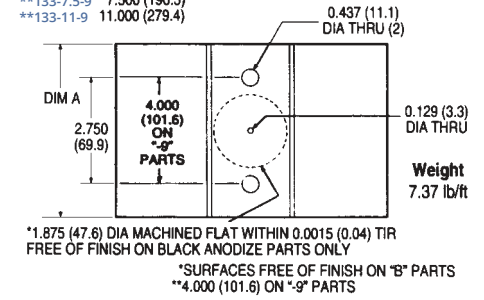
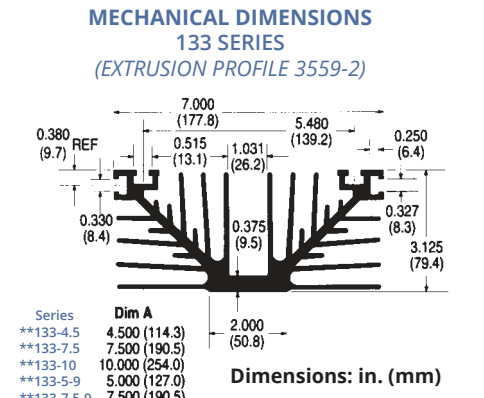
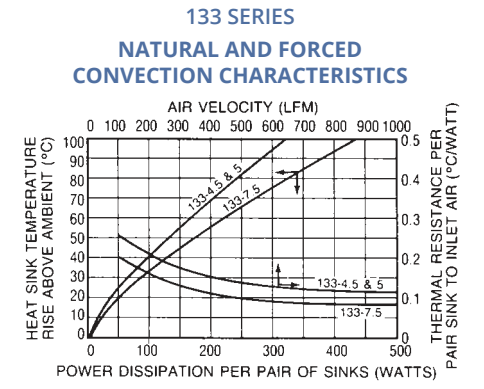

NOTES:

- Nominal dimensions for one heat sink of this type.
- Thermal performance values shown are per pair of heat sinks.
- Natural convection performance at 50°C heat sink rise above ambient.
- Black anodize finish [1.875 in. (47.6 mm) diameter spot face. Device mounting surface area free of finish].
- Predrilled heat sinks accept 130 and 139 Series clamp systems.

Clamp Assembly Procedure

All illustrations assume the following parts: 143 series crossbar, 143-2 spring leaf assembly and one or two 132-5-B9 heat sinks, compression SCR (not a Wakefield product), EJC No. 2 thermal joint compound (not a Wakefield product). Wakefield recommends using two heat sinks, one on each side of the SCR.

When received, the top edges of the force indicator should be in line with bottom edge of the spring leaf as shown below. This is the zero position. If this is not the case, move it to zero with your hands or a pair of pliers.

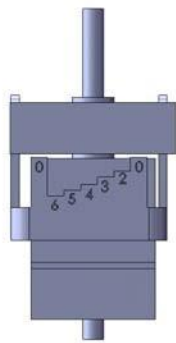

Too low

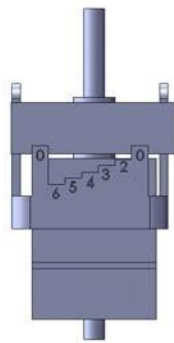

Too high

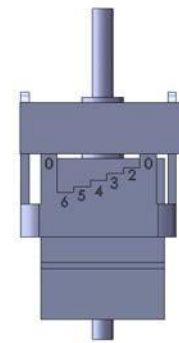

Proper zero position

If using one heat sink only: The roll pin will need to be adjusted to fit into the blind hole of the SCR. Check the depth of the blind hole and allow a clearance of at least 0.025 in (0.65 mm). Care will be needed to ensure that the upper retaining washer is held against the top leaf spring.

Keep washer fixed as shown

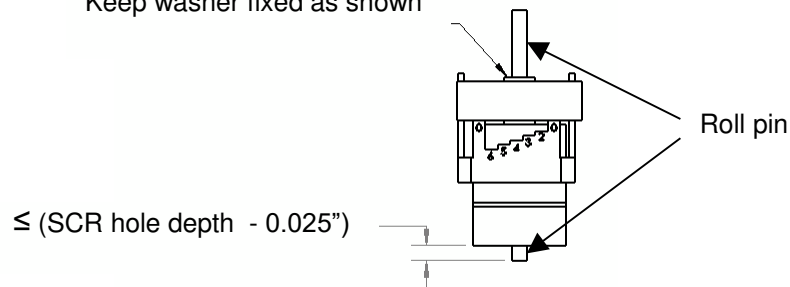

Clamp Assembly Procedure

If using two heat sinks on both sides of the component: place the heat sink on a flat surface and put the leaf spring assembly between the fins on center with the roll pin into the hole. With a hammer drive the pin into the hole and through the heat sink, so that the pin comes through the other side and protrudes 0.050 in (1.3 mm). This is helpful in indexing the SCR to keep it concentric to the forces applied when the nuts are tightened. This also holds the spring leaf assembly in place.

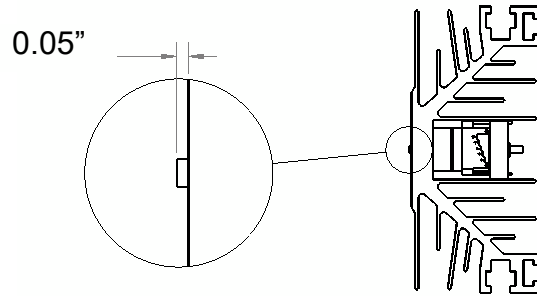

Apply a non-silicone based thermal compound to the spotface of the heat sink without the spring leaf assembly/roll pin. It is recommended that Electrical Joint Compound No. 2 (EJC #2) be used, as it contains a fluoride compound that removes the surface oxides on both the heat sink surface and the pole face of the SCR. Do not use Wakefield Type 120 compound, as it will cause a hot spot at this joint. There are many methods for applying the proper thickness of grease with full coverage and without excessive squeeze-out; this should be done by trial and error, removing the SCR and checking the amount of coverage.

Electrical Joint Compound No. 2 (EJC #2) is supplied by:

ACA Conductor Accessories
www.acasolutions.com
(800) 866-7385

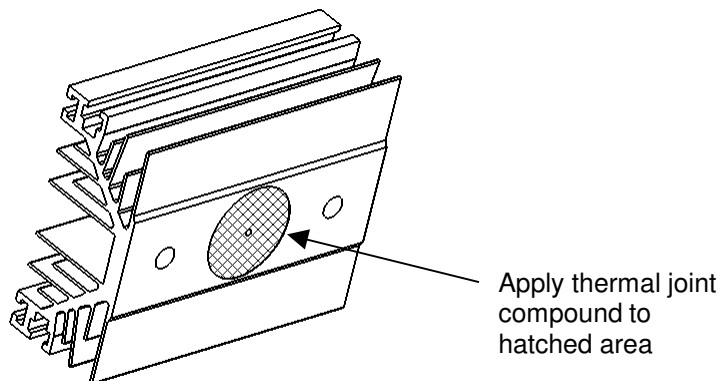

Clamp Assembly Procedure

Apply the thermal compound to the spotface of the heat sink with the spring leaf assembly and place the SCR in position on the spotface, centering the SCR on the roll pin. At this time fit the crossbar studs between the two innermost fins and through the holes of the other heat sink (without the spring leaf assembly). Slowly drop the crossbar studs through the holes in the heat sink with the SCR and spring leaf assembly, making sure that the SCR fits over the spotface on the upper heat sink. Then flip the assembly upside down, supporting the crossbar against the inner surface of the heat sink. Drop the washers over the threaded ends of the studs, and then apply the nuts to the threads and screw on until finger tight.

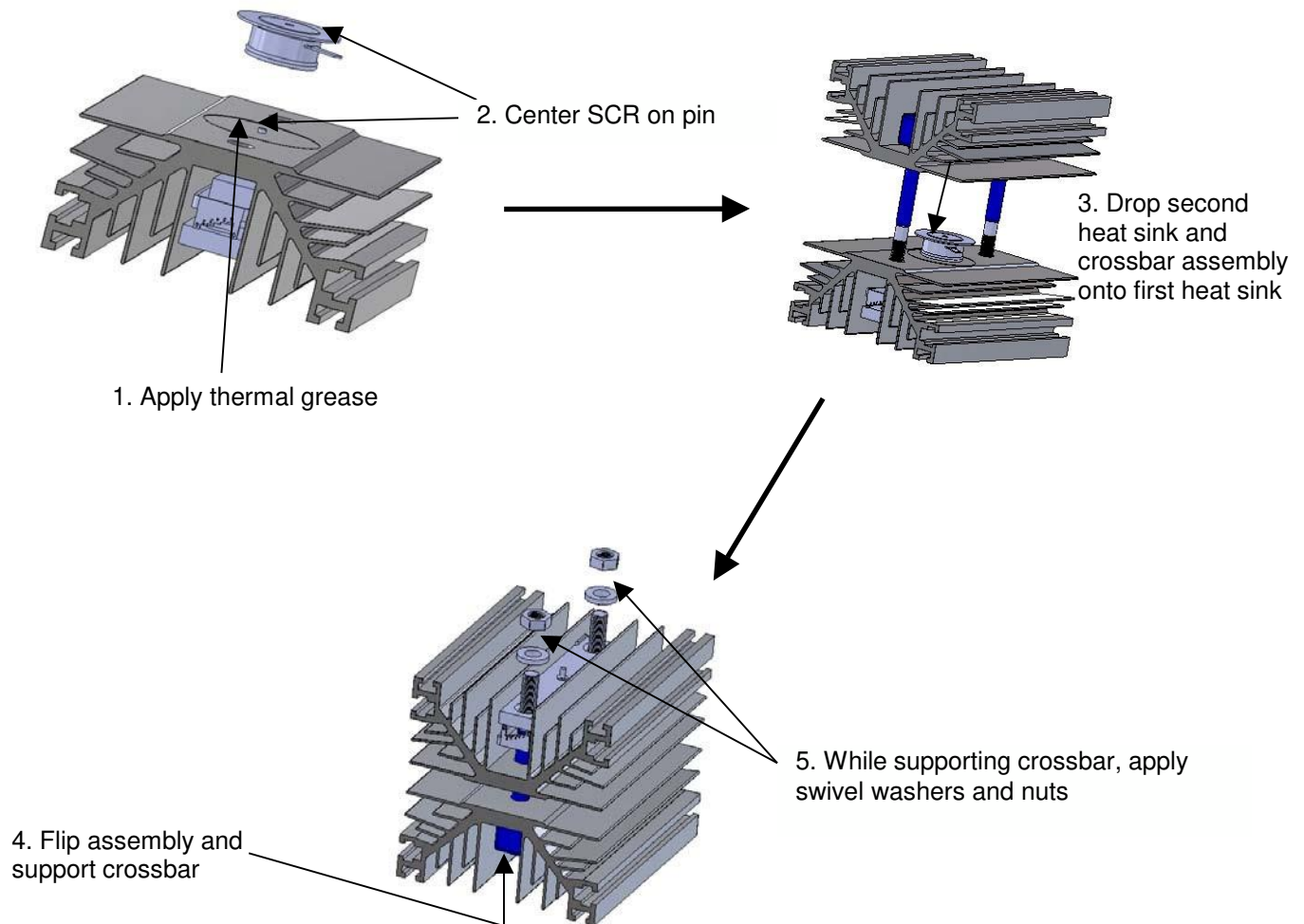

Clamp Assembly Procedure

Tighten the nuts alternately one-quarter turn each until you have reached the required force recommended for the SCR. This occurs when the edge of the marked step on the force indicator matches the bottom edge of the spring leaf as shown below.

"4" lines up with bottom edge of spring leaf \AA
4000 lb on 6000 lb scale

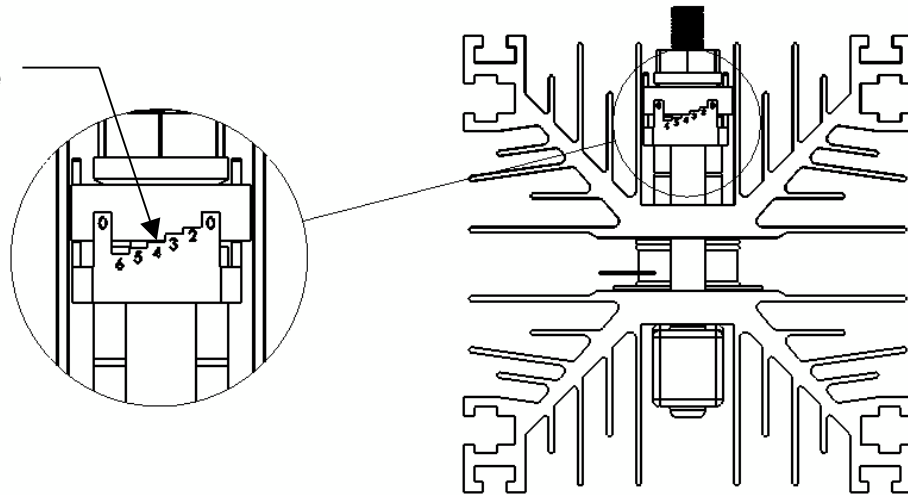

Additional notes:

Avoid short cuts in assembling these components, as it is important that deflection of the spring leaf assembly be given precedence over all other choices of force measuring techniques.

Do not use torque wrenches to set the force level, as torque is not a measure of force on these assemblies. The lubricants and surfaces of the nuts and washers will vary and cause a gross misrepresentation of force if torque is used as a force indicator.

Spotfaces are machined to a minimum depth to provide a flat surface for the SCR to sit on. The pole face of the SCR is only about 0.060 in (1.5 mm) above the surrounding bellows ring that is bonded to the SCR porcelain housing. The pole faces of the SCR deflect slightly as the force is applied to make contact to the silicon dioxide disc inside. If the spotface is too deep on the heat sink, the shoulder of the bellows will make contact to the heat sink, and the proper force required at the pole faces will not be met.

Every clamp/heat sink/SCR assembly will not have the same physical heat sink thicknesses to accommodate, and will require that the customer install small pins into the heat sinks to index the SCR's. The pins in the leaf spring assemblies will not be long enough in most cases and cannot be driven through the thicker heat sinks. In these applications the pin is driven into the heat sink a minimum distance to lock the leaf spring assembly to the heat sink.