

THIS DRAWING IS UNPUBLISHED. RELEASED FOR PUBLICATION
 © COPYRIGHT - By - ALL RIGHTS RESERVED.

LOC		DIST		REVISIONS			
P	LTR	DESCRIPTION		DATE	DWN	APVD	
	A2	REVISED PER ECO-11-005027		11MAR11	RK	HMR	

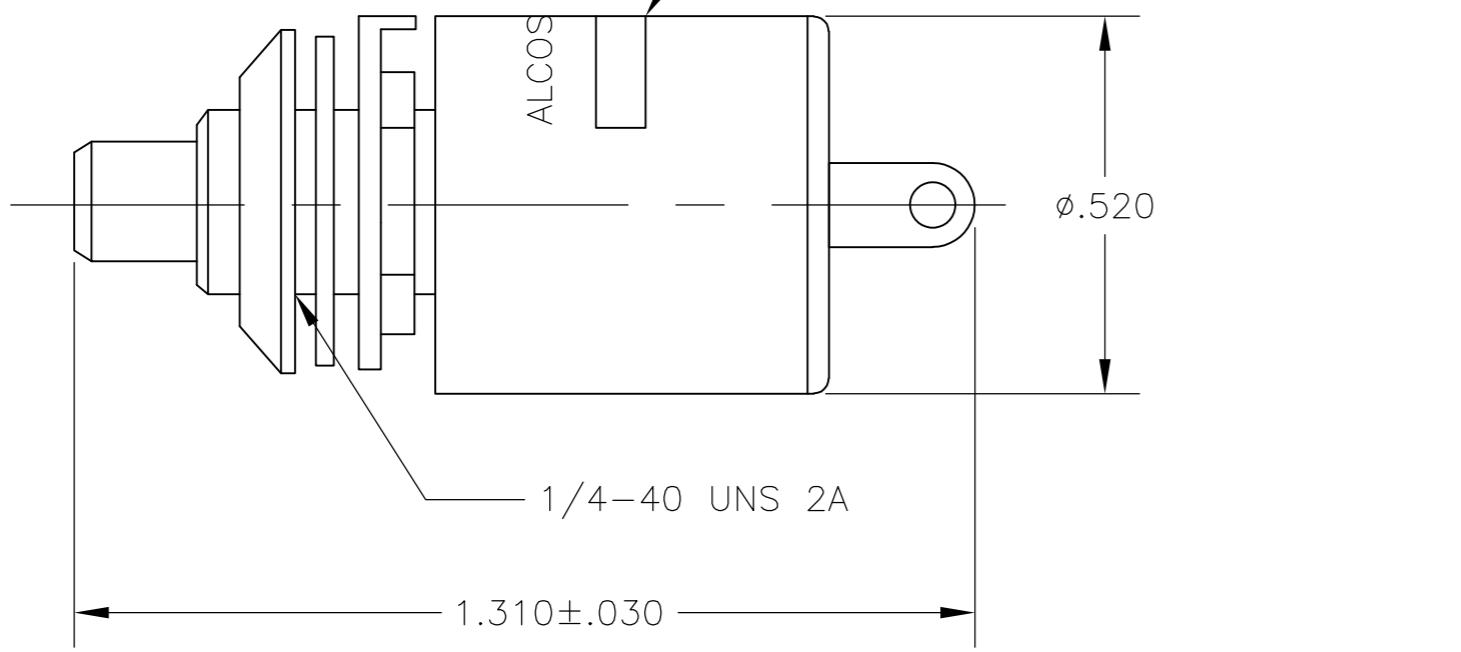

LUG TERMINAL

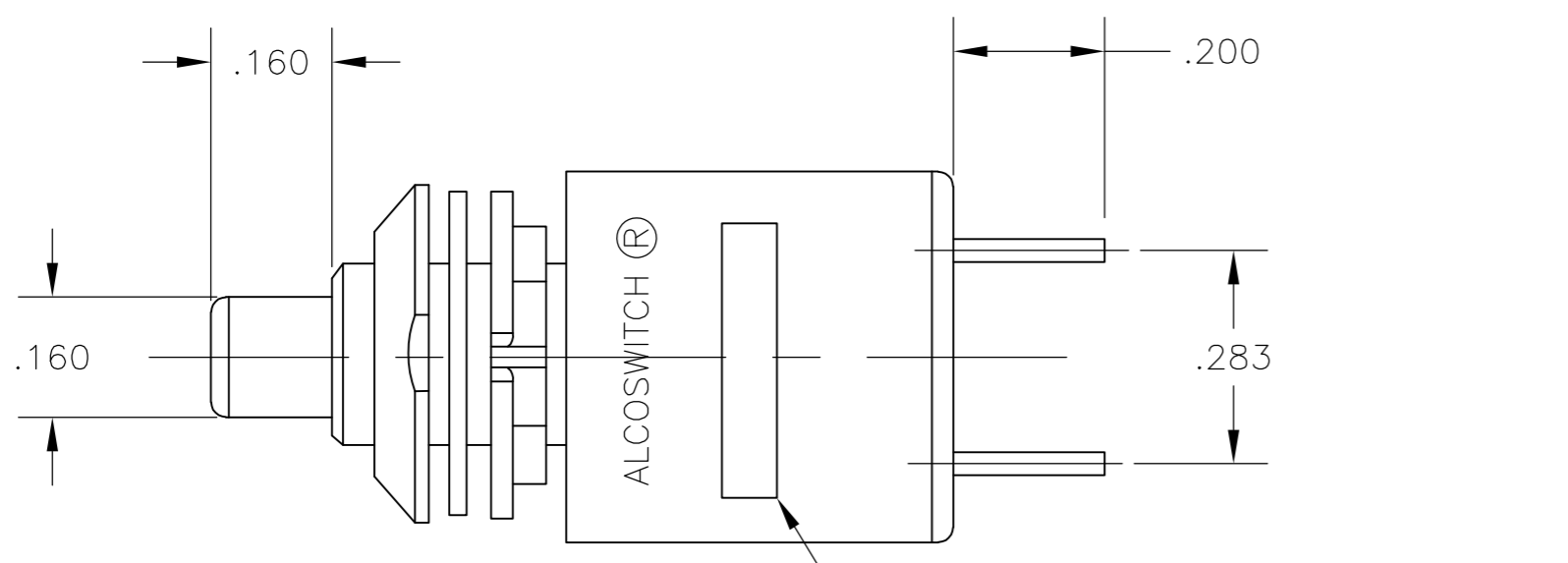
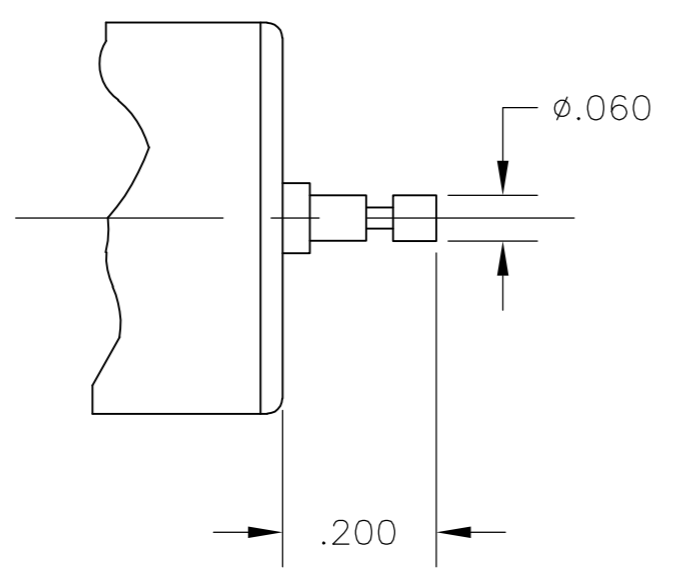

PIN TERMINAL OPTION

NOTES:

1. TERMINAL NUMBERS ARE FOR REFERENCE ONLY AND DO NOT APPEAR ON SWITCHES.
2. EACH SWITCH SUPPLIED WITH THE FOLLOWING MOUNTING HARDWARE:
 (1) DECORATIVE NUT
 (1) HEX NUT
 (1) INTERNAL TOOTH LOCKWASHER
 (1) LOCATING RING
3. ALL MATERIALS AND FINISHES SHALL COMPLY WITH EU DIRECTIVE 2002/95/EC OF 27JAN2003 (ROHS).
4. LUG TERMINALS ACCEPT STANDARD .110 QUICK CONNECT RECEPTACLES. PIN TERMINALS USEABLE FOR PCB APPLICATIONS.

TERMINAL STYLE	CAP COLOR	ACTION	THROWS	POLES	ALCO P/N	P/N
LUG	RED	NORMALLY OPEN	1	1	MSPM101CS104	1825539-4
PIN	RED	NORMALLY OPEN	1	1	MSPM101CS04	1825539-3
LUG	BLACK	NORMALLY CLOSED	1	1	MSPM101BS104	1825539-2
PIN	BLACK	NORMALLY CLOSED	1	1	MSPM101BS04	1825539-1

THIS DRAWING IS A CONTROLLED DOCUMENT.		DWN	14OCT92										
DIMENSIONS: INCHES		CHK	15OCT92										
TOLERANCES UNLESS OTHERWISE SPECIFIED:		APVD	19OCT92										
0 PLC ± - 1 PLC ± - 2 PLC ± - 3 PLC ± .010 4 PLC ± - ANGLES ± 1°		NAME J.JORDAN PRODUCT SPEC APPLICATION SPEC											
MATERIAL SEE SPECIFICATIONS		FINISH	SEE SPECIFICATIONS	WEIGHT	-	SIZE	A2	CAGE CODE	00779	DRAWING NO	1825539	RESTRICTED TO	-
CUSTOMER DRAWING		SCALE		4:1	SHEET	1 of 2	REV	A2					

THIS DRAWING IS UNPUBLISHED. RELEASED FOR PUBLICATION
 © COPYRIGHT - By - ALL RIGHTS RESERVED.

LOC	DIST	REVISIONS			
P	LTR	DESCRIPTION	DATE	DWN	APVD
AD	00	SEE SHEET 1	-	-	-

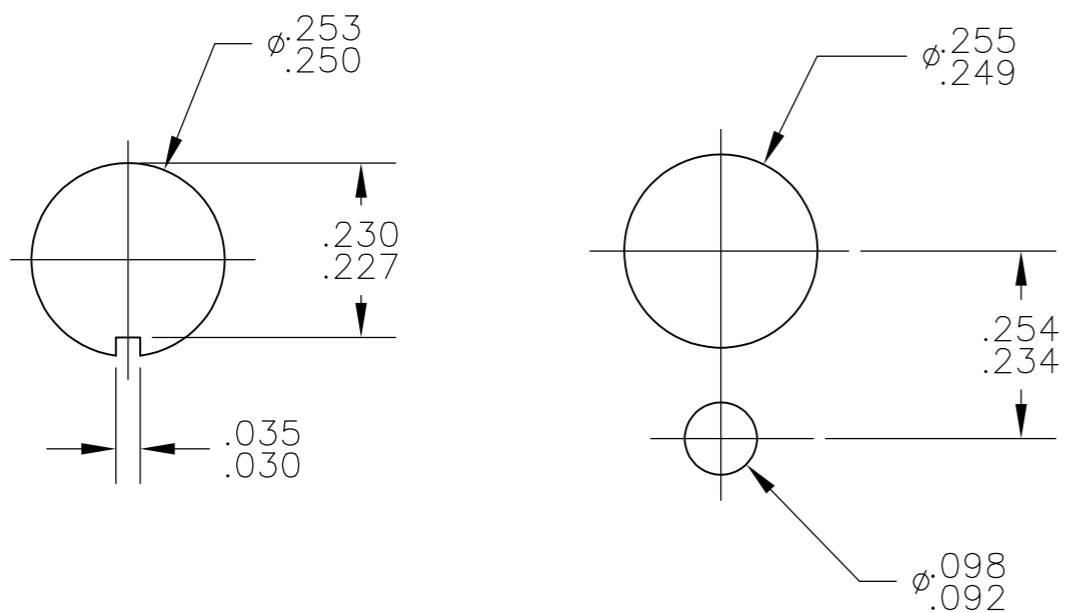

RECOMMENDED HOLE LAYOUT
TO PREVENT ROTATION

MATERIALS		
COMPONENT NAME	BASE MATERIAL	FINISH
CASE	STEEL	
ACTUATOR BUTTON	POLYAMIDE, SEE CHART FOR COLOR	
MOVING CONTACT	COPPER ALLOY	GOLD OVER NICKEL
FIXED CONTACT	COPPER ALLOY	GOLD OVER NICKEL
TERMINALS	COPPER ALLOY	TIN OVER NICKEL

SPECIFICATIONS	
RATING	1.0VA OPTIMUM (100mA MAX., 50 VDC MAX.)
INITIAL CONTACT RESISTANCE	100 MILLIOHMS
INSULATION RESISTANCE	1000 MEGOHMS MIN.
DIELECTRIC WITHSTANDING VOLTAGE	1000 VRMS AT SEA LEVEL
DURABILITY	500000 CYCLES AT .1VA 50000 CYCLES AT 5VA
OPERATING FORCE	TACTILE KEYBOARD FEEL 4 TO 7 OZ. BREAKAWAY REDUCING IMMEDIATELY TO 1.5 OZ. FOLLOW-THROUGH
TRAVEL	.079 +/- .008
OPERATING TEMPERATURE	-10C TO +80C
STORAGE TEMPERATURE	-10C TO +80C

THIS DRAWING IS A CONTROLLED DOCUMENT.		DWN	M.M.	14OCT92	 TE Connectivity
DIMENSIONS: INCHES		CHK	RAY.D	15OCT92	
TOLERANCES UNLESS OTHERWISE SPECIFIED:		APVD	J.JORDAN	19OCT92	
0 PLC ± - 1 PLC ± - 2 PLC ± - 3 PLC ± .010 4 PLC ± - ANGLES ± 1°		NAME			
MATERIAL SEE SPECIFICATIONS		FINISH SEE SPECIFICATIONS		WEIGHT	-
		PRODUCT SPEC APPLICATION SPEC		SIZE	A2
CUSTOMER DRAWING		SCALE 4:1		CAGE CODE	00779
		SHEET 2 OF 2		DRAWING NO	1825539
		REV A2		RESTRICTED TO	-