

P	LTR	DESCRIPTION	DATE	DWN	APVD
	L5	REVISED PER ECN-22-156403	03JUN2022	RK	CSD

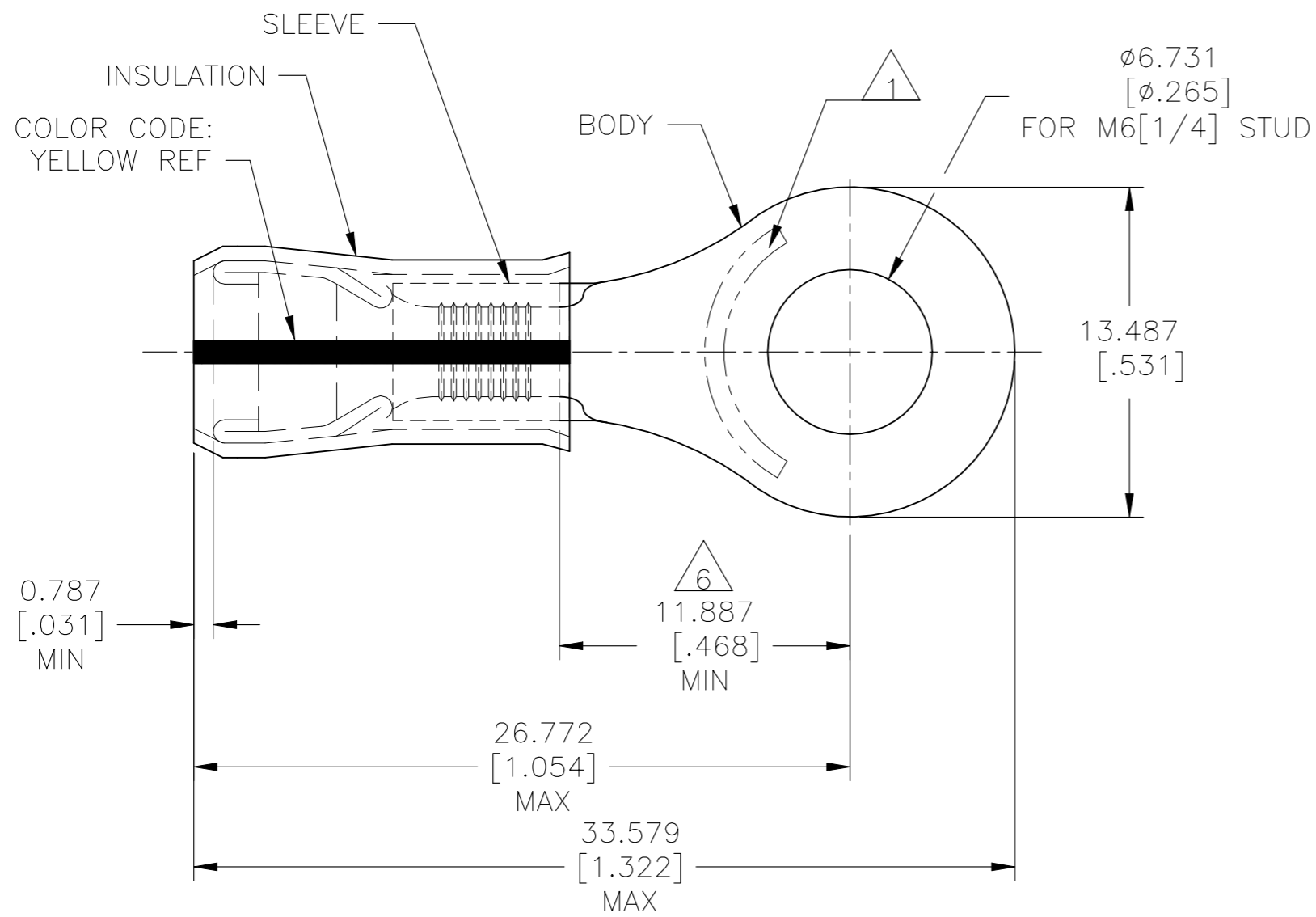
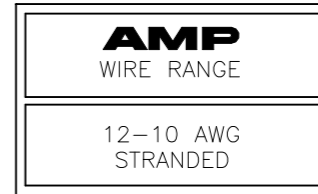

- 1 STAMP AMP 12-10* APPROX AS SHOWN.
- 2 WIRE INSULATION : $\phi 3.810-5.842[\phi .150-.230]$
- 3 BODY MATERIAL THK: $0.991 \pm 0.051[.039 \pm .002]$
- 4 FINISH:
BODY & SLEEVE: TIN-LEAD (93-7) PLATE PER ASTM B545,
(3% MIN LEAD CONTENT)
INSULATION: COLOR-NATURAL.
- 5 MATERIAL:
BODY & SLEEVE: CU PER ASTM B152
INSULATION: PVF2,
- 6 APPLIES FROM EDGE OF METAL WIRE BARREL
TO CENTER OF STUD HOLE.
- 7 MEETS M7928/4-157, CLASS 1
MEETS M7928/13-157. CLASS 1

500	LOOSE PIECE	53426-1
QTY	PACKAGE TYPE	PART NO

AMP INCORPORATED CUSTOMER SERVICE SYSTEMS		MAX RECOMMENDED OPERATING TEMPERATURE: 150°C [302°F] MAX	THIS DRAWING IS A CONTROLLED DOCUMENT.		DWN JR RUTH 160CT07	TE Connectivity NAME TERMINAL, RING TONGUE, PVF2 , P.I.D.G. WIRE SIZE: 12-10 AWG			
FOR ADDITIONAL PRODUCT INFORMATION OR COPIES OF DRAWINGS AND TECHNICAL DOCUMENTS	PRODUCT INFORMATION CENTER 1-800-522-6752	VOLTAGE RATING: -	DIMENSIONS: mm [INCHES]	TOLERANCES UNLESS OTHERWISE SPECIFIED:	CHK T MICHELUTTI 160CT07				APVD T MICHELUTTI 160CT07
FOR APPLICATION TOOLING INFORMATION	TOOLING ASSISTANCE CENTER 1-800-722-1111	CIRCULAR MIL AREA: 2.62-6.64mm² [5,180-13,100] STRANDED		0 PLC ± - 1 PLC ± - 2 PLC ± - 3 PLC ± 0.127[.005] 4 PLC ± - ANGLES ± -	APPLICATION SPEC 114-2157	WEIGHT -	SIZE A3	CAGE CODE 00779	DRAWING NO C-53426
FOR ORDER ENTRY	1-800-526-5142	THIS DRAWING IS A CONTROLLED DOCUMENT FOR AMP INCORPORATED. IT IS SUBJECT TO CHANGE AND THE CONTROLLING ENGINEERING ORGANIZATION SHOULD BE CONTACTED FOR THE LATEST REVISION.	MATERIAL 5	FINISH 4	CUSTOMER DRAWING		SCALE 4:1	SHEET 1 OF 1	REV L5