



Eliminate the need for hard wiring systems with the NEW Souriau UTS threaded receptacles

NPT, PG & M threaded receptacle - Threads into existing installation allowing for easy conversion from a hard wired to pluggable solution

- | | | |
|--|---|---|
| NPT, PG & M threaded receptacle | ✓ | No need to change drilling pattern when using the UTS threaded receptacle as your connector solution! |
| UL 1977 qualified | ✓ | Easy qualification of your System by regulation authorities |
| Fire & smoke: UL94-VO | ✓ | Suitable for public environment |
| IP68/69K + UV resistant | ✓ | Suitable for outdoor use |
| Hexagonal shape | ✓ | Easy to fasten to a box with standard wrench |



UTS Series

UTS range overview

The UTS series offers a range of plastic connectors rugged enough to withstand industrial applications.

The bayonet coupling system makes it simple to use. With only a 1/3 twist of the coupling ring, connectors are mated with an audible and sensitive "click".



UTS series is available with a diverse range of options.....

Everything from power & signal connectors, box mounted receptacles, cable mounted plugs, cable mounted in-line and PCB mounted receptacles.

A full range of wire termination options include: Crimp, Solder and Screw.



Screw termination version

The philosophy of the UTS series is built around three key elements:

Dynamic IP68/69K



UTS series is rated at IP68/69K... even in dynamic conditions. This means that it remains sealed even when used continuously underwater or cleaned using a high pressure hose and cable is moving.

This extreme level of performance is achievable with jacketed cable or discrete wires.

If this same level of performance is required when connectors are not mated, we offer the UTS Hi Seal; a product designed to remain watertight if an environmental cap is not fitted or if the equipment is likely to get wet when cables have been disconnected.

UV Resistant



In most applications, our connectors are exposed to extreme climatic conditions; it was therefore key for us to select the materials best able to cope with the targeted environment.

Part of our product qualification process involved subjecting connectors to a simulated five years of exposure to various elements including Temperature, UV and Humidity.

The results were positive in that there were no visible signs of weakness, such as cracking.

UL/IEC Compliant



The utmost priority for any electrical installation is to protect personnel from any shock hazard.

In North America, Underwriters Laboratories requires connector manufacturers to respect their standards based on application use.

In Europe and in Asia, IEC standards are better known and trusted by end users. Like its American equivalent, the IEC refers to safety rules. The UTS series was obviously designed to respect these rules.

UTS Series

Layout

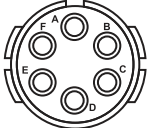
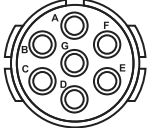
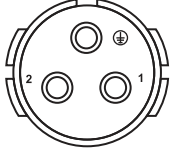
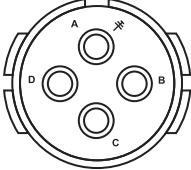
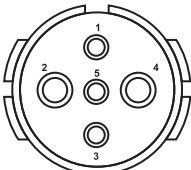
Shell size	Contact size
10	 <p data-bbox="808 688 1101 743">106 - 10E6 6 x #20 (Ø 1.0) - M16x1.5</p>
	 <p data-bbox="808 995 1101 1050">10E7 7 x #20 (Ø 1.0) - M16x1.5</p>
14	 <p data-bbox="820 1304 1089 1358">142G1 3 x #8 (Ø 3.6) - NPT 1/2</p>
18	 <p data-bbox="815 1610 1092 1665">183G1 4 x #8 (Ø 3.6) - NPT 3/4"</p>
	 <p data-bbox="722 1917 1187 1971">18X2M3 2 x #8 (Ø 3.6) + 3 x #16 (Ø 1.6) - NPT 3/4"</p>

Contact identification positions shown are for mating face of pin contact connectors and wire face of socket contact connectors.

UTS Series 142G1



Specifications

Contact type	Connector type	Backshell	Part number	
			Male insert	Female insert
Crimp contacts supplied separately see page 7	Free hanging receptacle	Cable gland (Fig. 1)	UTS1JC142G1P	UTS1JC142G1S ☺
	Plug	Without (Fig.3)	UTS6142G1P	UTS6142G1S ☺
		Cable gland (Fig.4)	UTS6JC142G1P ☺	UTS6JC142G1S ☺
	Jam nut receptacle	Without (Fig.2)	UTS7142G1P ☺	UTS7142G1S ☺
	NPT threaded receptacle	Without (Fig.5)		 UTS7142G1SNPT ☺

48h sample service ☺

UTS Series

142G1

2 + ground
44A/600V
per UL 1977

Dimensions

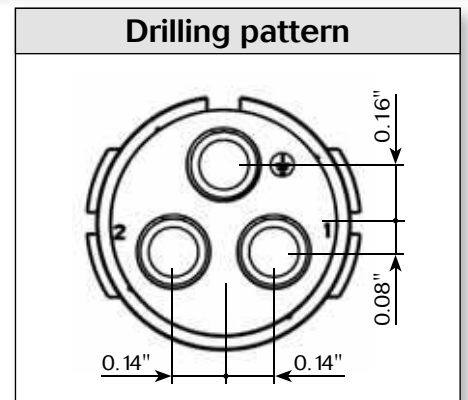
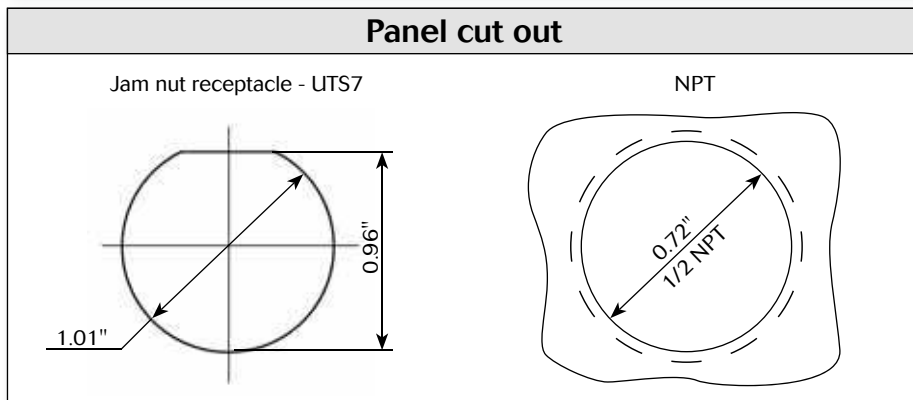
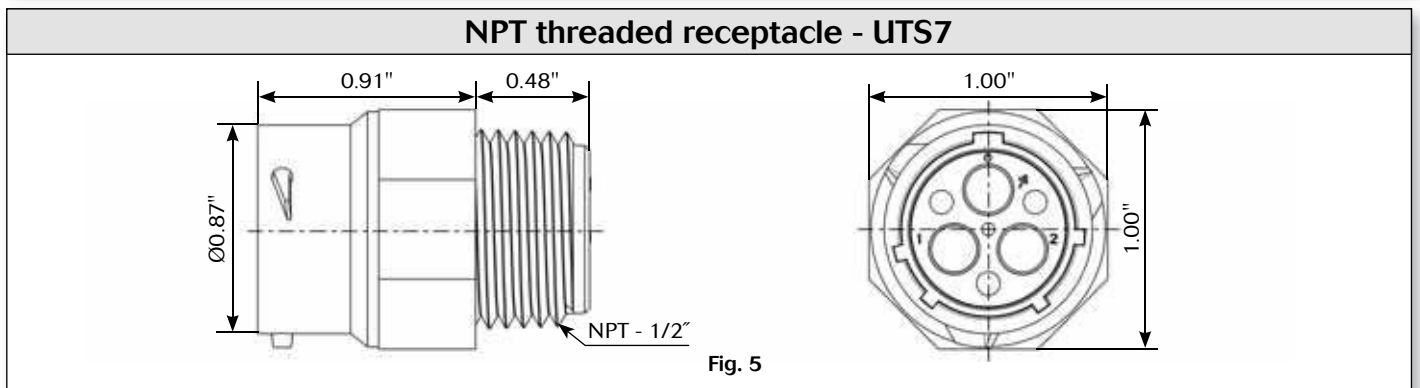
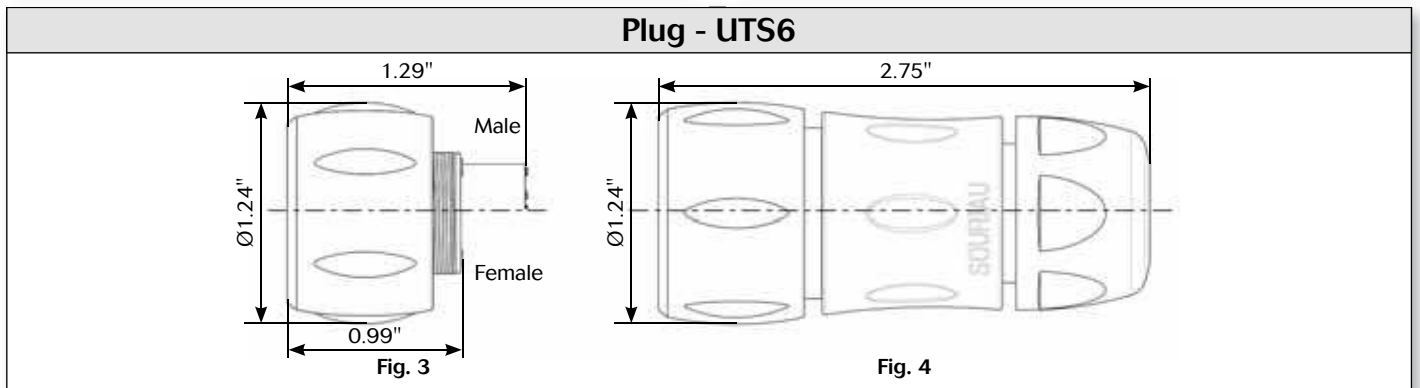
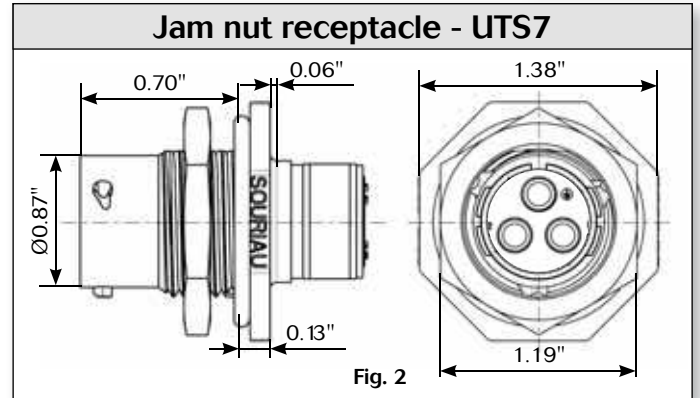
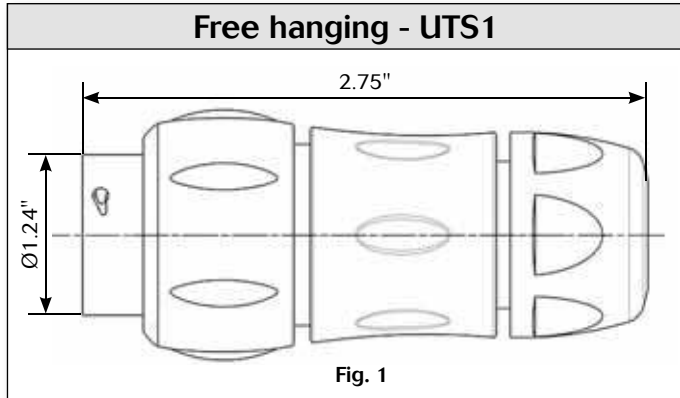

Note: All dimensions in inches unless otherwise noted.

UTS Series

142G1

Accessories and tooling

Jam nut sealing caps



Part number
UTS14DOG



Metal terminal

Part number
UTS14DOGR

Hand tool



Part number
M817

Plug sealing cap



Part number
UTS614DOG

Positioner + locator setting



Part number
VGE10078A

Plastic protective cap



Part numbers	
Receptacle cap	Plug cap
85005588A	85005597

Extraction tool



Part number
51060210936

Color coding rings

G for Green

Y for Yellow

R for Red



Part numbers	
Receptacles	Plugs
UTS714CCRR	UTS614CCRR
UTS714CCRY	UTS614CCRY
UTS714CCRG	UTS614CCRG

* Add G for Green, Y for Yellow, R for Red

UTS Series

142G1

2 + ground
44A/600V
per UL 1977

Contacts

#8	Contact type	AWG	Part number		Max wire Ø (inch)	Max insulator Ø (inch)
			Male	Female		
Crimp	Machined	16	82913601A ⁽¹⁾ Ⓢ	82913600A ⁽¹⁾ Ⓢ	-	0.25"
		14	82913603A ⁽¹⁾ Ⓢ	82913602A ⁽¹⁾ Ⓢ	-	
		12	82913605A ⁽¹⁾ Ⓢ	82913604A ⁽¹⁾ Ⓢ	-	
		10	82913607A ⁽¹⁾ Ⓢ	82913606A ⁽¹⁾ Ⓢ	-	
		8	82913609A ⁽¹⁾ Ⓢ	82913608A ⁽¹⁾ Ⓢ	-	

(1): Example of plating, for other plating see page 26

48h sample service Ⓢ

Electrical characteristics

UL
44A 600V UL94 V-0

CSA
30A 600V UL94 V-0

IEC
40A 300V 4kV 3

UTS 142G1 derating curves

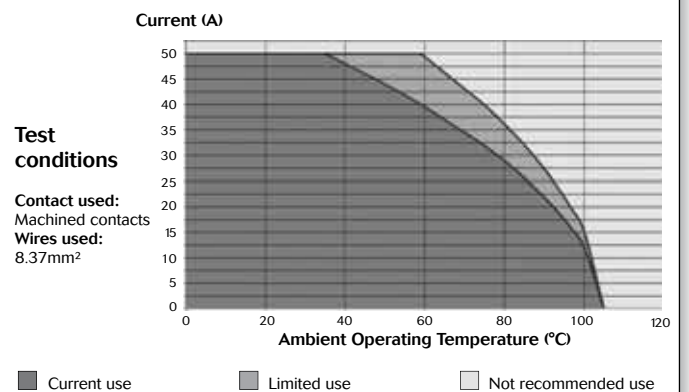

UTS Series

183G1

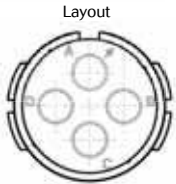

Specifications

Contact type	Connector type	Backshell	Part number	
			Male insert	Female insert
Crimp contacts supplied separately see page 11	NPT threaded receptacle	Without (Fig.1)	UTS7183G1 PNPT	UTS7183G1 SNPT ☺
	Plug	Without (Fig.2)	UTS6183G1 P	UTS6183G1 S
	Plug	Cable gland (Fig.3)	UTS6JC183G1 P ☺	UTS6JC183G1 S

48h sample service ☺

UTS Series

183G1

3 + ground
44A/600V
per UL 1977

Dimensions

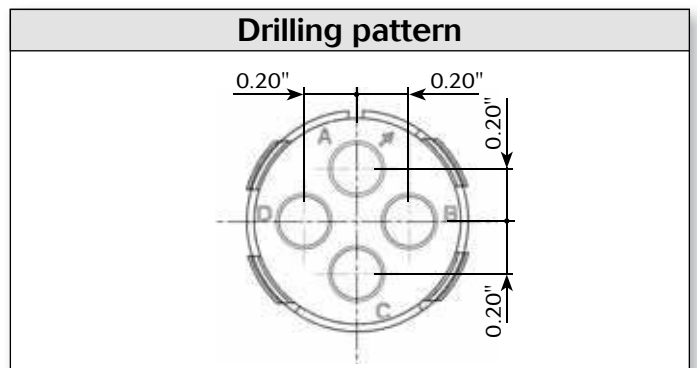
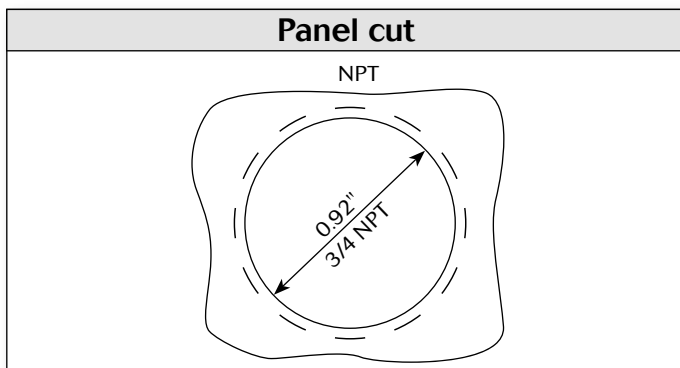
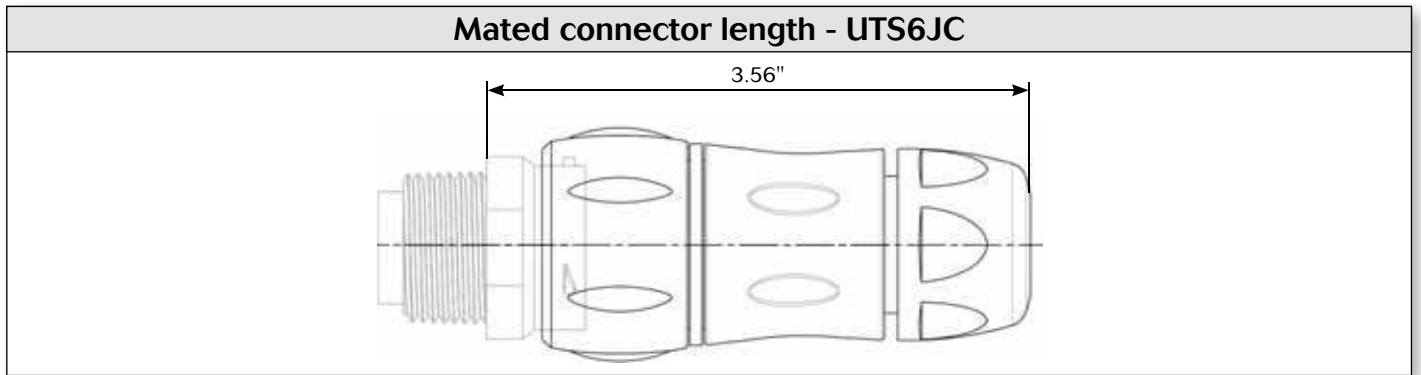
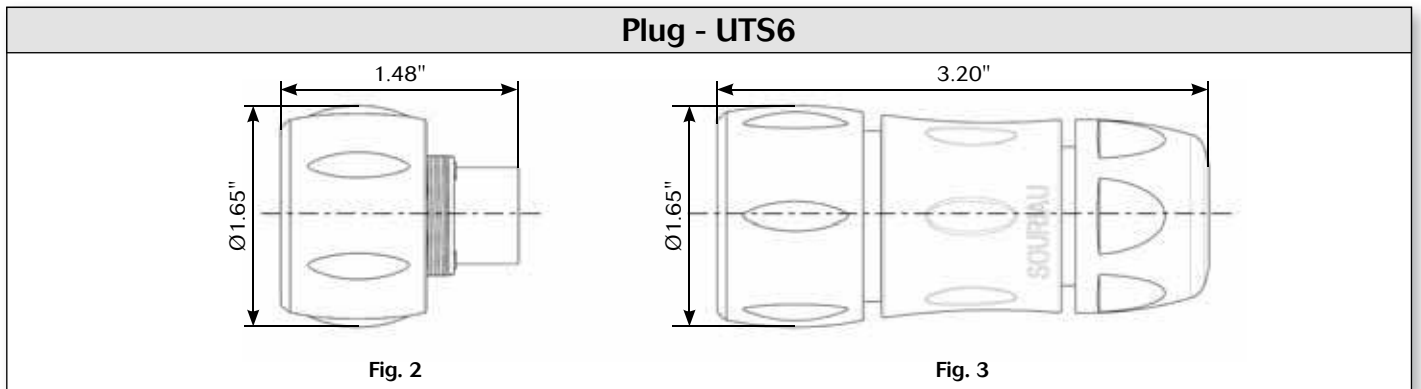
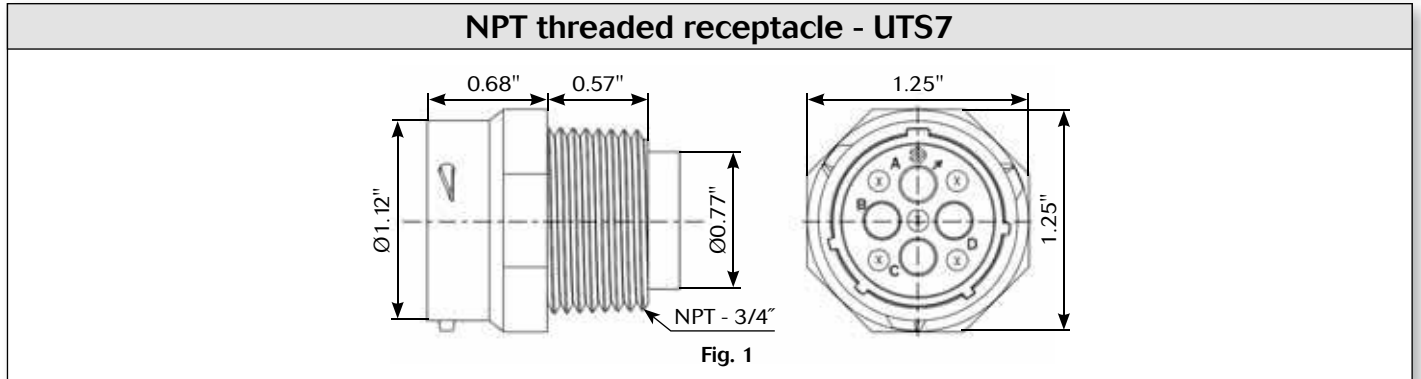

Note: All dimensions in inches unless otherwise noted.

UTS Series

183G1

Accessories and tooling

Jam nut sealing caps



Part number
UTS18DOG



Metal terminal

Part number
UTS18DOGR

Hand tool



Part number
M817

Plug sealing cap



Part number
UTS618DOG

Positioner + locator setting



Part number
VGE10078A

Plastic protective cap



Part numbers	
Receptacle cap	Plug cap
85005590A	85005599

Extraction tool



Part number
51060210936

Color coding rings

G for Green



Y for Yellow



R for Red



Part numbers	
Receptacles	Plugs
UTS714CCRR	UTS614CCRR
UTS714CCRY	UTS614CCRY
UTS714CCRG	UTS614CCRG

* Add G for Green, Y for Yellow, R for Red

UTS Series

183G1

3 + ground
44A/600V

per UL 1977

Contacts

#8	Contact type	AWG	Part number		Max wire Ø (inch)	Max insulator Ø (inch)
			Male	Female		
Crimp	Machined	16	82913601A ⁽¹⁾ Ⓢ	82913600A ⁽¹⁾ Ⓢ	-	0.25"
		14	82913603A ⁽¹⁾ Ⓢ	82913602A ⁽¹⁾ Ⓢ	-	
		12	82913605A ⁽¹⁾ Ⓢ	82913604A ⁽¹⁾ Ⓢ	-	
		10	82913607A ⁽¹⁾ Ⓢ	82913606A ⁽¹⁾ Ⓢ	-	
		8	82913609A ⁽¹⁾ Ⓢ	82913608A ⁽¹⁾ Ⓢ	-	

(1): Example of plating, for other plating see page 26

48h sample service Ⓢ

Electrical characteristics

UL
44A 600V UL94 V-0

CSA
26A 600V UL94 V-0

IEC
32A 300V 4kV 3

UTS 183G1 derating curves

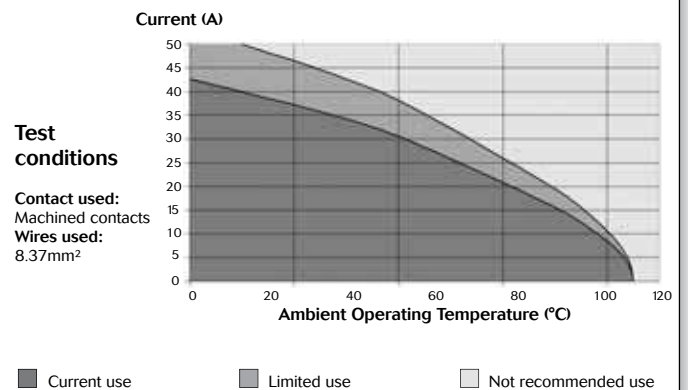

UTS Series

106 - 10E6



Specifications

Contact type	Connector type	Backshell	Part number	
			Male insert	Female insert
Crimp contacts supplied separately see page 15	Free hanging receptacle	Cable gland (Fig.1)	UTS1JC106P	UTS1JC106S
	Plug	Without (Fig.2)	UTS6106P	UTS6106S
	Plug	Cable gland (Fig.3)	UTS6JC106P	UTS6JC106S
	Jam nut receptacle	Without (Fig.4)	UTS7106P	UTS7106S
Hand solder electrical contacts loaded	Square flange receptacle	Without (Fig.6)	UTS010E6P	UTS010E6S
	Plug	Without (Fig.2)	UTS610E6P	UTS610E6S
		Cable gland (Fig.3)	UTS6JC10E6P	UTS6JC10E6S
Jam nut receptacle	Without (Fig.5)	UTS710E6P	UTS710E6S	
PCB contacts supplied separately see page 15	Jam nut receptacle	Without (Fig.4)	UTS7106P	UTS7106S
Hand solder electrical contacts loaded	NPT threaded receptacle	Without (Fig.7)	UTS710E6PMI 6	UTS710E6SMI 6

Sealed unmated

UTS Series

106 - 10E6

6 contacts
6A/250V
per UL 1977

Dimensions

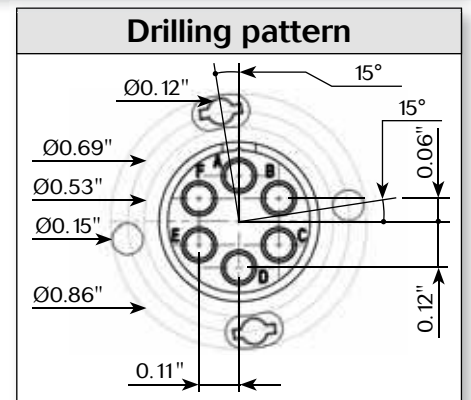
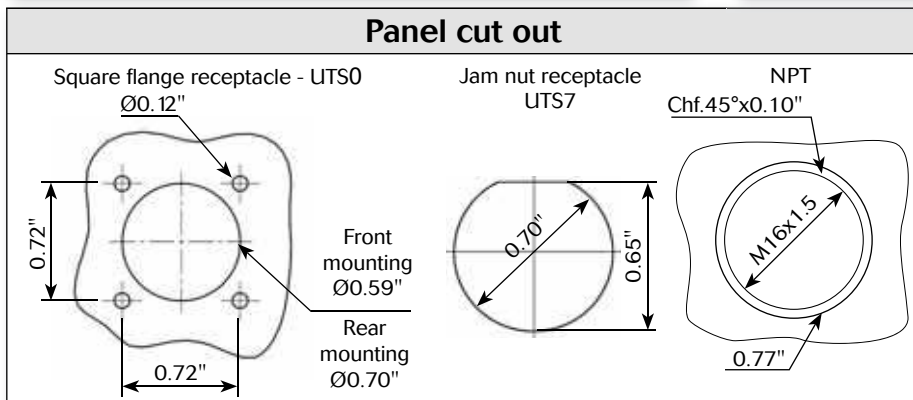
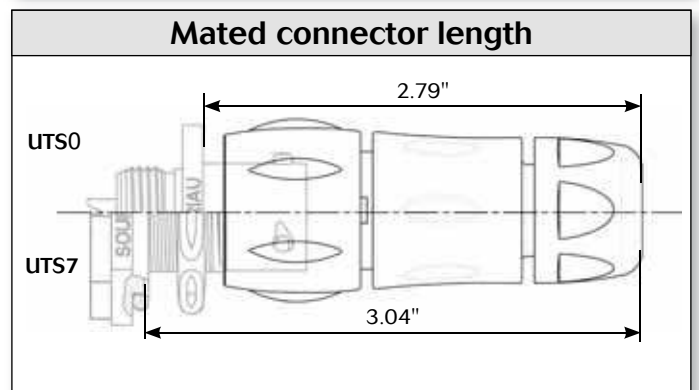
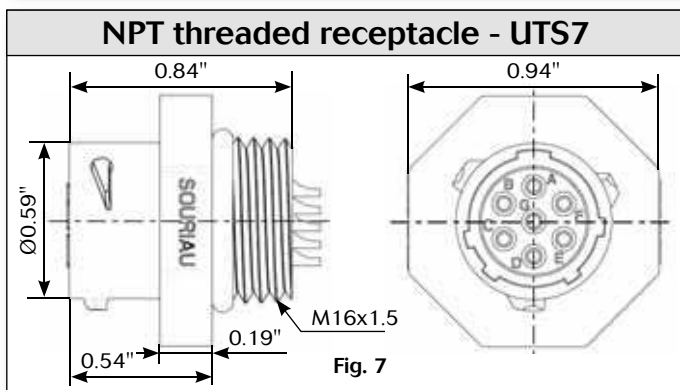
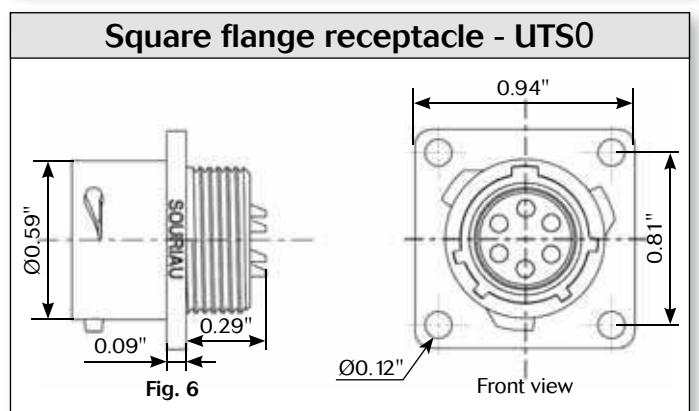
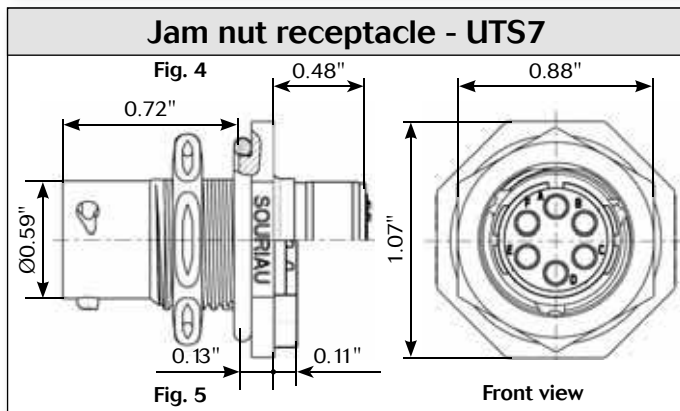
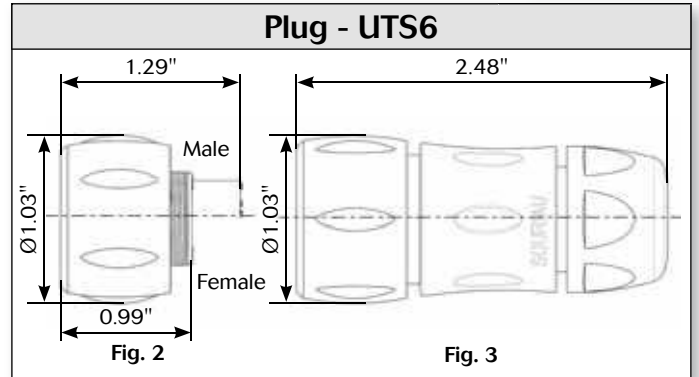
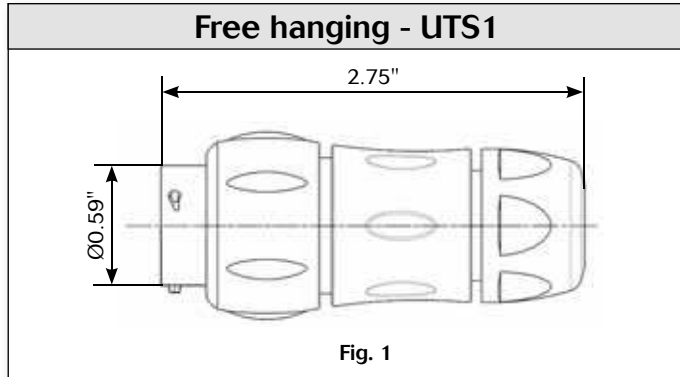

Note: All dimensions in inches unless otherwise noted.

UTS Series

106 - 10E6

Accessories and tooling

Jam nut sealing caps



Part number
UTS10DCG



Metal terminal

Part number
UTS10DCGR

Handle



Part number
SHANDLES

Tool kit



Part number
TOOLKIT

Plug sealing cap



Part number
UTS610DCG

Square flange sealing cap



Metal terminal

Part number
UTS10DCGE

Plastic protective cap



Part numbers	
Receptacle cap	Plug cap
85005586A	85005595

Gasket



Part numbers / neoprene
UTFD12B

Crimp tooling



Contacts	Contact size	Part number of head
FM RC 24V8K ⁽¹⁾	Standard contacts #20 Ø0.03"	S20FM
FM RC 20V8K ⁽¹⁾		S20FM
FM RC 18V8K ⁽¹⁾		S20FM
SM SC 24V8S ⁽²⁾		S20SCM20
SM SC 24V8S ⁽³⁾		S20SCM20
SM SC 20V8S ⁽²⁾		S20SCM20
SM SC 20V8S ⁽³⁾	S20SCM20	

⁽¹⁾: Example of plating, for other plating see page 26
⁽²⁾: contact reeled
⁽³⁾: loose contact

Color coding rings

G for Green

Y for Yellow

R for Red

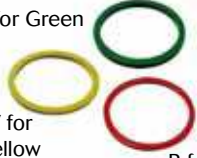

Part numbers	
Receptacles	Plugs
UTS710CCRR	UTS610CCRR
UTS710CCRY	UTS610CCRY
UTS710CCRG	UTS610CCRG

* Add G for Green, Y for Yellow, R for Red

UTS Series

106 - 10E6

6 contacts
6A/250V
per UL 1977

Contacts

#20	Contact type	AWG	Part number		Max wire Ø (inch)	Max insulator Ø (inch)
			Male	Female		
Crimp	Machined	26-24	FM24W8K ⁽¹⁾ ⊙	FC24W8K ⁽¹⁾ ⊙	-	0.06"
		22-20	FM20W8K ⁽¹⁾ ⊙	FC20W8K ⁽¹⁾ ⊙	-	0.06"
		20-18	FM18W8K ⁽¹⁾ ⊙	FC18W8K ⁽¹⁾ ⊙	-	0.08"
	stamped & formed reeled contacts	26-24	SM24WL3TK6 ⁽²⁾	SC24WL3TK6 ⁽²⁾	-	0.03"-0.06"
		26-24	SM24WL3TK6 ⁽²⁾	SC24WL3TK6 ⁽²⁾	-	0.03"-0.06"
		22-20	SM20WL3TK6 ⁽²⁾	SC20WL3TK6 ⁽²⁾	-	0.04"-0.08"
		22-20	SM20WL3TK6 ⁽²⁾	SC20WL3TK6 ⁽²⁾	-	0.04"-0.08"
	PCB	Machined	-	FM5016K ⊙	FC5016K ⊙	-

(1): Example of plating, for other plating see page 26

(2): To obtain contact reeled remove L in part number. Example: SM20M1TK6

48h sample service ⊙

Electrical characteristics

UTS 106	UTS 10E6
UL	UL
5A 250V UL94 V-0	6A 250V UL94 HB
CSA	CSA
4A 250V UL94 V-0	6A 250V UL94 HB
IEC	
7A 32V 1.5kV 3	

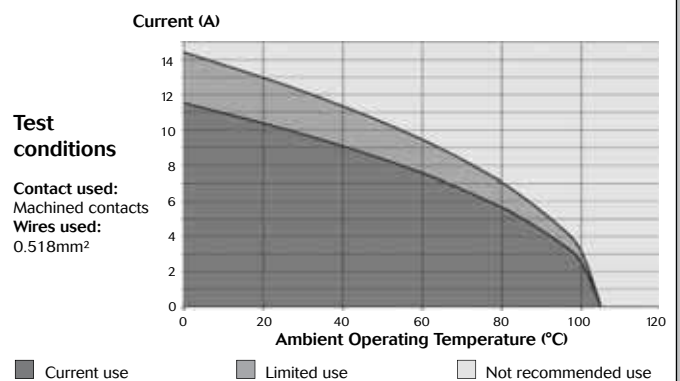

UTS 106 - 10E6 derating curves

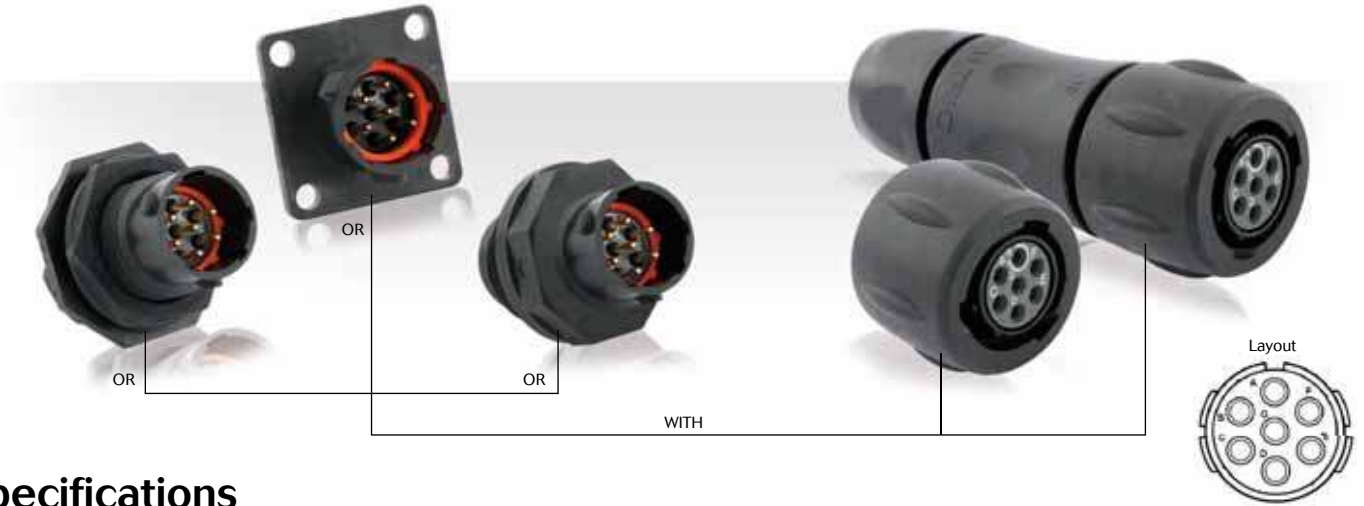

UTS Series 10E7



Specifications

Contact type	Connector type	Backshell	Part number	
			Male insert	Female insert
Hand solder electrical contacts loaded	Square flange receptacle	Without (Fig.1)	UTS010E7P	UTS010E7S
	Plug	Without (Fig.2)	UTS610E7P	UTS610E7S
		Cable gland (Fig.3)	UTS6JC10E7P	UTS6JC10E7S
	Jam nut receptacle	Without (Fig.4)	UTS710E7P	UTS710E7S
NPT threaded receptacle	Without (Fig.5)	 UTS710E7PMI 6	 UTS710E7SMI 6	

Sealed unmated

UTS Series

10E7

7 contacts
6A/250V
per UL 1977

Dimensions

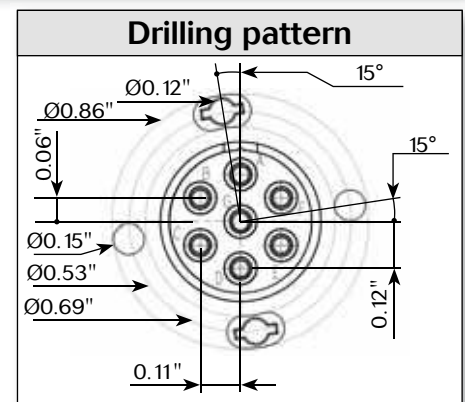
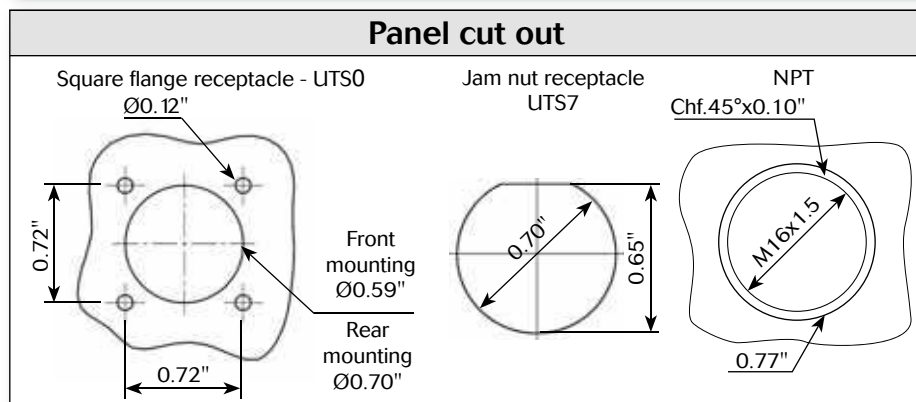
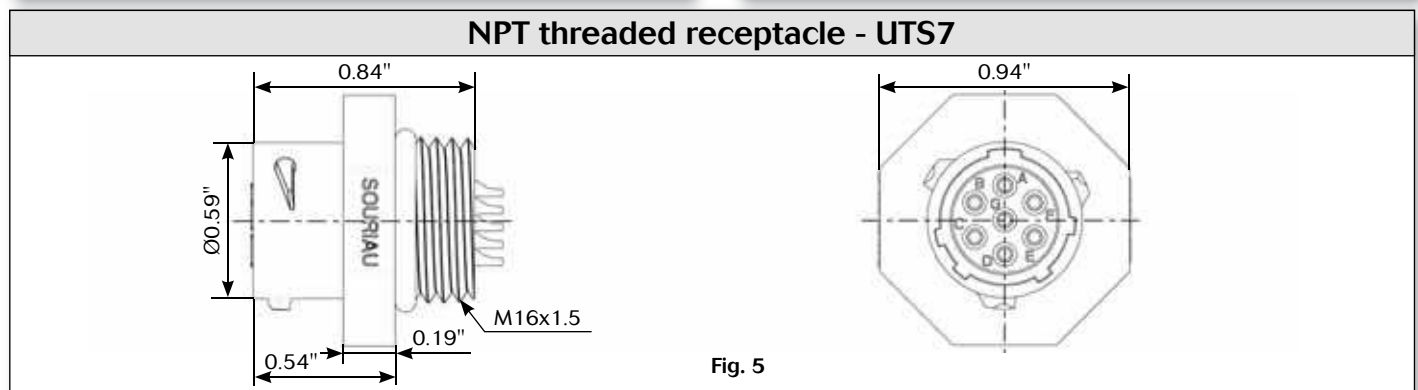
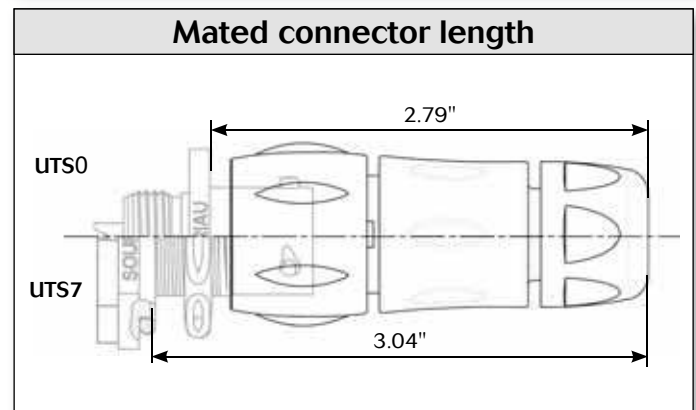
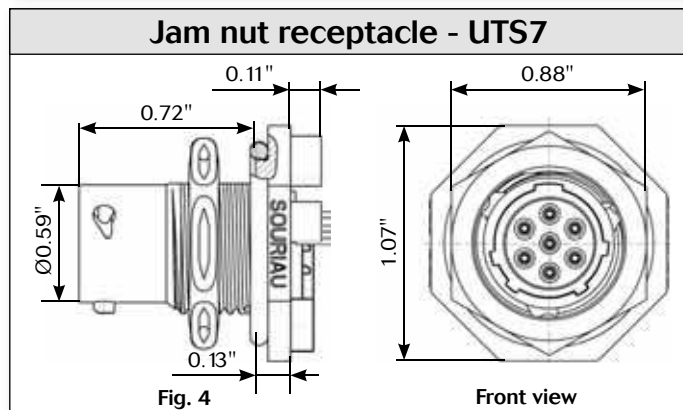
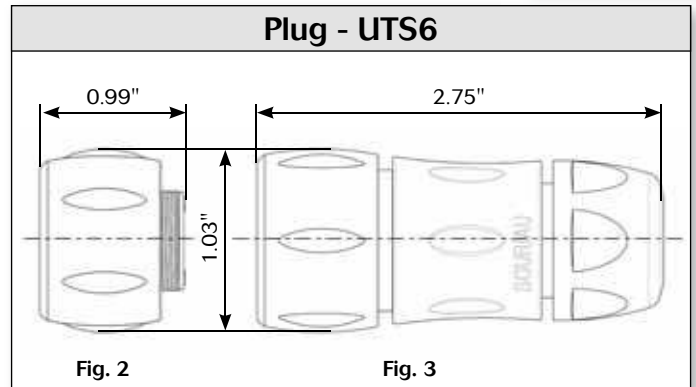
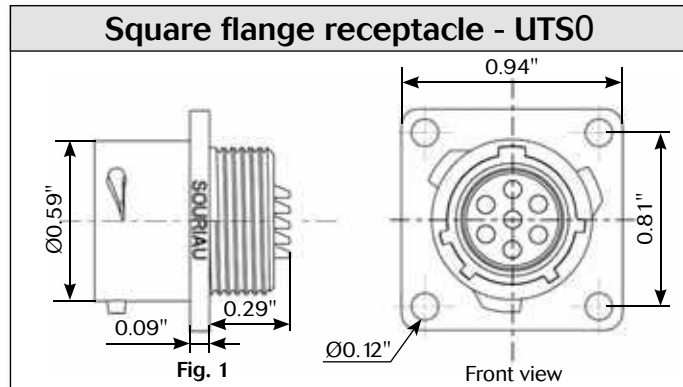

Note: All dimensions in inches unless otherwise noted.

UTS Series

10E7

Accessories and tooling

Jam nut sealing caps					
					
<table border="1" style="width: 100%; border-collapse: collapse;"> <tr><th style="text-align: center;">Part number</th></tr> <tr><td style="text-align: center;">UTS10DCG</td></tr> </table>	Part number	UTS10DCG	<table border="1" style="width: 100%; border-collapse: collapse;"> <tr><th style="text-align: center;">Part number</th></tr> <tr><td style="text-align: center;">UTS10DCGR</td></tr> </table>	Part number	UTS10DCGR
Part number					
UTS10DCG					
Part number					
UTS10DCGR					

Plug sealing cap		
		
<table border="1" style="width: 100%; border-collapse: collapse;"> <tr><th style="text-align: center;">Part number</th></tr> <tr><td style="text-align: center;">UTS610DCG</td></tr> </table>	Part number	UTS610DCG
Part number		
UTS610DCG		

Square flange sealing cap		
		
<table border="1" style="width: 100%; border-collapse: collapse;"> <tr><th style="text-align: center;">Part number</th></tr> <tr><td style="text-align: center;">UTS10DCGE</td></tr> </table>	Part number	UTS10DCGE
Part number		
UTS10DCGE		

Plastic protective cap							
							
<table border="1" style="width: 100%; border-collapse: collapse;"> <tr><th colspan="2" style="text-align: center;">Part numbers</th></tr> <tr> <th style="text-align: center;">Receptacle cap</th> <th style="text-align: center;">Plug cap</th> </tr> <tr> <td style="text-align: center;">85005586A</td> <td style="text-align: center;">85005595</td> </tr> </table>		Part numbers		Receptacle cap	Plug cap	85005586A	85005595
Part numbers							
Receptacle cap	Plug cap						
85005586A	85005595						

Gasket		
		
<table border="1" style="width: 100%; border-collapse: collapse;"> <tr><th style="text-align: center;">Part numbers / neoprene</th></tr> <tr><td style="text-align: center;">UTFD12B</td></tr> </table>	Part numbers / neoprene	UTFD12B
Part numbers / neoprene		
UTFD12B		

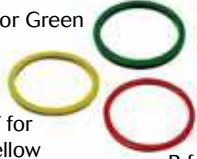
Color coding rings											
<p>G for Green</p> <p>Y for Yellow</p> <p>R for Red</p> 	<table border="1" style="width: 100%; border-collapse: collapse;"> <tr><th colspan="2" style="text-align: center;">Part numbers</th></tr> <tr> <th style="text-align: center;">Receptacles</th> <th style="text-align: center;">Plugs</th> </tr> <tr> <td style="text-align: center;">UTS710CCRR</td> <td style="text-align: center;">UTS610CCRR</td> </tr> <tr> <td style="text-align: center;">UTS710CCRY</td> <td style="text-align: center;">UTS610CCRY</td> </tr> <tr> <td style="text-align: center;">UTS710CCRG</td> <td style="text-align: center;">UTS610CCRG</td> </tr> </table>	Part numbers		Receptacles	Plugs	UTS710CCRR	UTS610CCRR	UTS710CCRY	UTS610CCRY	UTS710CCRG	UTS610CCRG
Part numbers											
Receptacles	Plugs										
UTS710CCRR	UTS610CCRR										
UTS710CCRY	UTS610CCRY										
UTS710CCRG	UTS610CCRG										
<p>* Add G for Green, Y for Yellow, R for Red</p>											

UTS Series

10E7

7 contacts
6A/250V
per UL 1977

Electrical characteristics

UL
6A 250V UL94 HB

CSA
6A 250V UL94 HB

IEC
7A 50V 1.5kV 3

UTS 10E7 derating curves

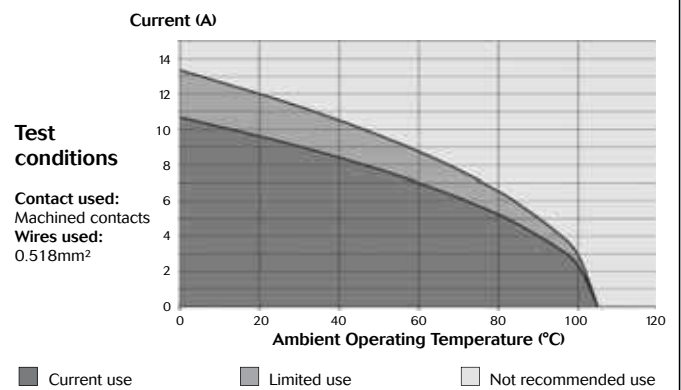

UTS Series

18X2M3

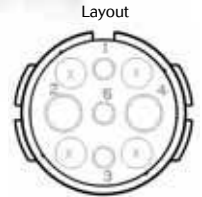

Specifications

Contact type	Connector type	Backshell	Part number	
			Male insert	Female insert
Crimp contacts supplied separately see page 23	NPT threaded receptacle	Without (Fig.1)	UTS718X2M8PNPT	UTS718X2M8SNPT
	Plug	Without (Fig.2)	UTS618X2M8P	UTS618X2M8S
	Plug	Cable gland (Fig.3)	UTS6JC18X2M8P	UTS6JC18X2M8S

48h sample service

UTS Series

18X2M3

5 contacts
44A/600V
per UL 1977

Dimensions

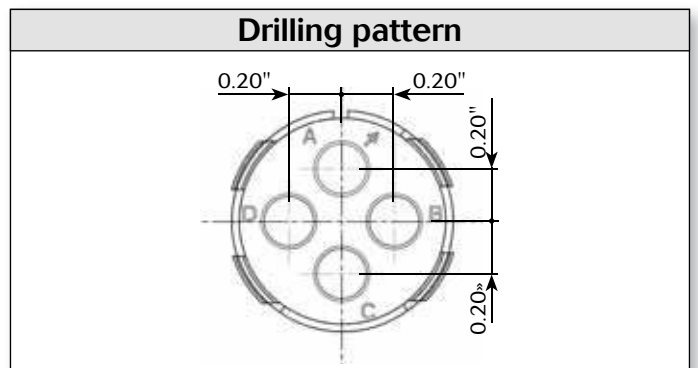
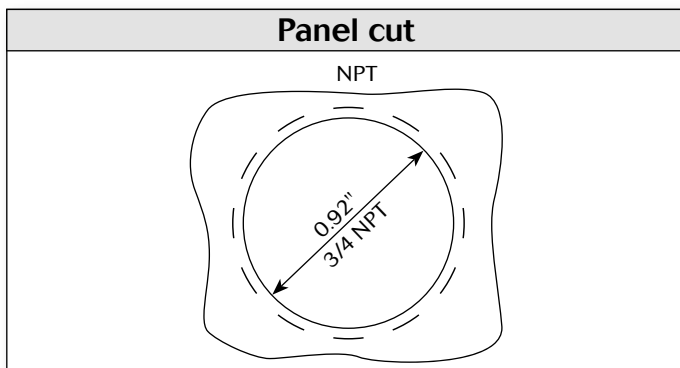
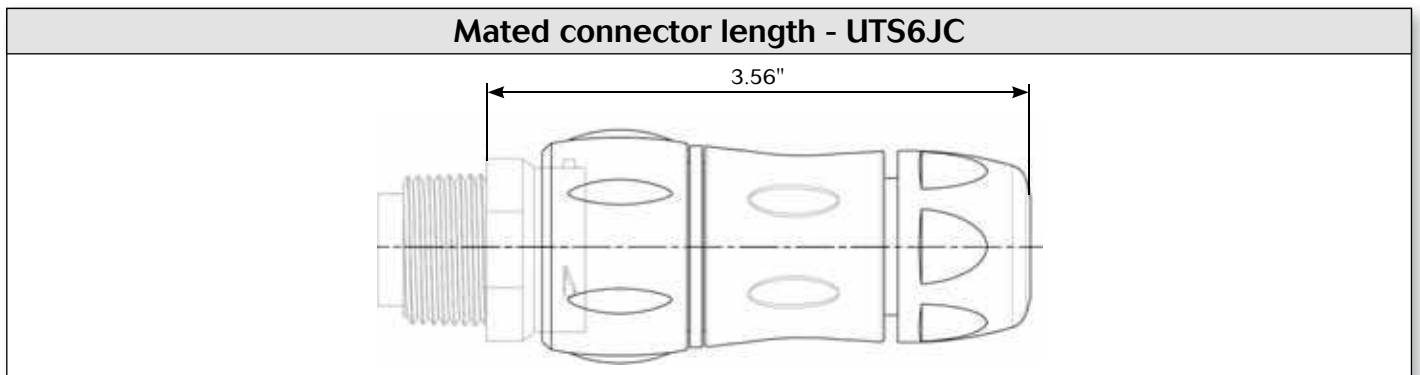
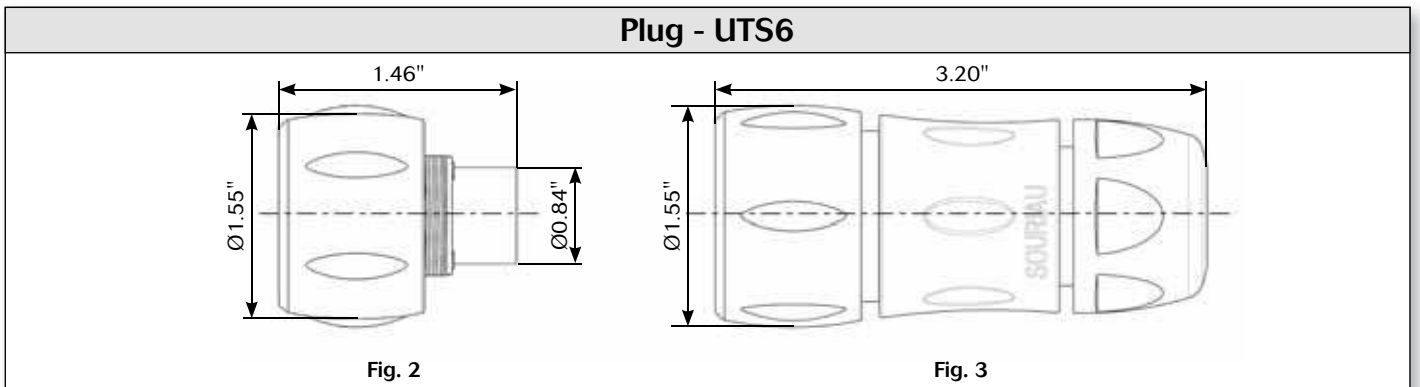
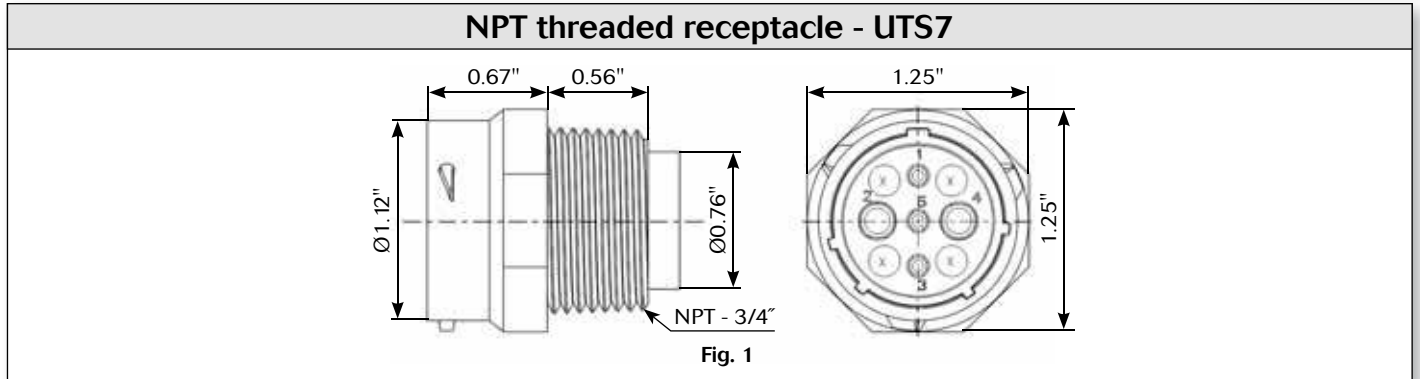

Note: All dimensions in inches unless otherwise noted.

UTS Series

18X2M3

Accessories and tooling

Jam nut sealing caps



Part number
UTS18DOG



Metal terminal

Part number
UTS18DOGR

Plug sealing cap



Part number
UTS618DOG

Plastic protective cap



Part numbers	
Receptacle cap	Plug cap
85005590A	85005599

Color coding rings

G for Green

Y for Yellow

R for Red

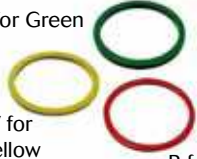

Part numbers	
Receptacles	Plugs
UTS714CCRR	UTS614CCRR
UTS714CCRY	UTS614CCRY
UTS714CCRG	UTS614CCRG

* Add G for Green, Y for Yellow, R for Red

Crimp tooling #16



Part number
SHANDLES



Part number
TOOLKIT



Contacts	Contact size	Part number of head
FM FC 28MI K ⁽¹⁾	Standard contacts #16 Ø0.06"	S16FCM20
FM FC 24MØK ⁽¹⁾		S16FCM20
FM FC 20MI3K ⁽¹⁾		S16FCM20
FM FC 20MI2K ⁽¹⁾		S16FCM20
FM FC 16M23K ⁽¹⁾		S16FCMI6
FM FC 14M50K ⁽¹⁾		S16FCMI450
FM FC 14M80K ⁽¹⁾		S16FCMI4
SM SC 24ML1TK6 ⁽¹⁾		S16SCM20
SM SC 20ML1TK6 ⁽¹⁾		S16SCM20
SM SC 16ML1TK6 ⁽¹⁾		S16SCML1
SM SC 14ML1TK6 ⁽¹⁾		S16SCML1
SM SC 16ML11TK6 ⁽¹⁾		S16SCML11

(1): Example of plating, for other plating see page 26

Crimp tooling #8



Part number hand tool
MB17



Part number positioner + locator setting
VGE10078A



Part number extraction tool
51060210924

UTS Series

18X2M3

5 contacts
44A/600V
per UL 1977

Contacts

#16	Contact type	AWG	Part number		Max wire Ø (inch)	Max insulator Ø (inch)
			Male	Female		
Crimp	Machined	30-28	FM28MI K ⁽¹⁾ ⊙	FC28MI K ⁽¹⁾ ⊙	0.02"	0.04"
		26-24	FM24MØK ⁽¹⁾ ⊙	FC24MØK ⁽¹⁾ ⊙	0.03"	0.06"
		22-20	FM20MI 3K ⁽¹⁾ ⊙	FC20MI 3K ⁽¹⁾ ⊙	0.04"	0.07"
		22-20	FM20MI 2K ⁽¹⁾ ⊙	FC20MI 2K ⁽¹⁾ ⊙	0.04"	0.08"
		20-16	FMI 6M23K ⁽¹⁾ ⊙	FC16M23K ⁽¹⁾ ⊙	0.07"	0.12"
		16-14	FMI 4M50K ⁽¹⁾	FC14M50K ⁽¹⁾	0.08"	0.12"
		16-14	FMI 4M80K ⁽¹⁾ ⊙	FC14M80K ⁽¹⁾ ⊙	0.08"	0.12"
	Stamped & formed reeled contacts	26-24	SM24ML1TK6 ⁽¹⁾⁽²⁾	SC24ML1TK6 ⁽¹⁾⁽²⁾	0.03"-0.05"	-
		22-20	SM20ML1TK6 ⁽¹⁾⁽²⁾	SC20ML1TK6 ⁽¹⁾⁽²⁾	0.04"-0.08"	-
		18-16	SM16ML1TK6 ⁽¹⁾⁽²⁾	SC16ML1TK6 ⁽¹⁾⁽²⁾	0.11"	-
		18-16	SMI 6ML11TK6 ⁽¹⁾⁽²⁾	SCI 6ML11TK6 ⁽¹⁾⁽²⁾	0.07"-0.11"	-
14		SM14ML1TK6 ⁽¹⁾⁽²⁾	SC14ML1TK6 ⁽¹⁾⁽²⁾	0.12"	-	
PCB	Machined	-	FM20MI 2E8K ⁽¹⁾	FC20MI 2E84K ⁽¹⁾	-	-

#8	Contact type	AWG	Part number		Max wire Ø (mm)	Max insulator Ø (mm)
			Male	Female		
Crimp	Machined	16	82913601A ⁽¹⁾ ⊙	82913600A ⁽¹⁾ ⊙	-	0.25"
		14	82913603A ⁽¹⁾ ⊙	82913602A ⁽¹⁾ ⊙	-	
		12	82913605A ⁽¹⁾ ⊙	82913604A ⁽¹⁾ ⊙	-	
		10	82913607A ⁽¹⁾ ⊙	82913606A ⁽¹⁾ ⊙	-	
		8	82913609A ⁽¹⁾ ⊙	82913608A ⁽¹⁾ ⊙	-	

(1): Example of plating, for other plating see page 26

(2): To obtain contact reeled remove L in part number. Example: SM20MI TK6

48h sample service ⊙

Electrical characteristics

UL
44A 600V UL94 V-0

CSA
34A 600V UL94 V-0

IEC
32A 300V 4kV 3

UTS 183G1 derating curves

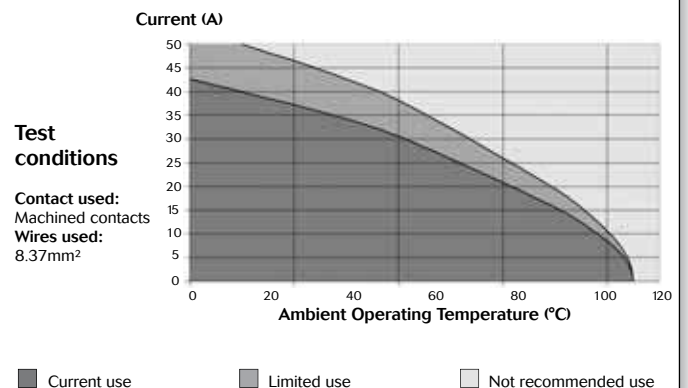

UTS Series

Technical information

Assembly instruction



UTS NPT assembly (mounting suggestion)

- Place the wires into the panel hole
- UTS standard version: Strip wires and crimp the contacts. Recommended strip length: see below
- UTS Hi Seal version: strip wires and solder the contacts. Recommended strip length: 0.19"
- Tighten the connector to the recommended torque (see table)

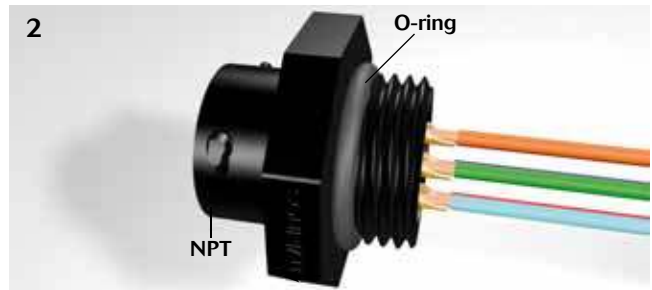
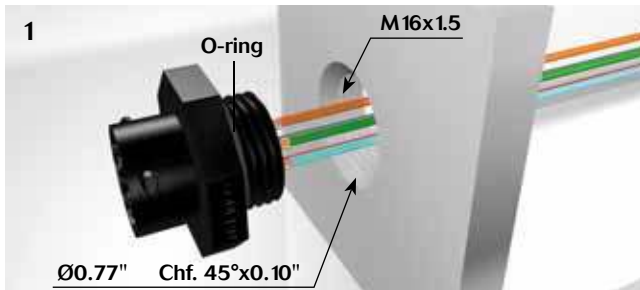
Shell size	Jam nut torque (Nm)	Tool tightening width (inch)
10	3	0.87"
14	5	1.18"
18	5	1.43"



Wire stripping crimp version

	Part number		Stripping length L (inch)
	Male	Female	
Machined contact 	#20		0.18"
	FM24V8- / FM20V8- FM18V8-	FC24V8- / FC20V8- FC18V8-	
	#16		0.18"
	FM28M- / FM24M0- FM20M3- / FM20M2-	FC28M- / FC24M0- FC20M3- / FC20M2-	
	FM16M23- / FM14M80-	FC16M23- / FC14M80-	
#8		0.25" to 0.29"	
8291 3601- / 8291 3603- 8291 3605- / 8291 3607- 8291 3609-	8291 3600- / 8291 3602- 8291 3604- / 8291 3606- 8291 3608-		
Stamped & formed Without insulation support 	#16		0.15"
	SM24M- / SM24ML1- SM20M- / SM20ML1-	SC24M- / SC24ML1- SC20M- / SC20ML1-	
	SM16M11- / SM16ML11-	SC16M11- / SC16ML11-	0.18"
	With insulation support 	SM16M- / SM16ML1-	SC16M- / SC16ML1-
SM4M- / SM4ML1-		SC16M11- / SC16ML11-	0.24"

UTS Series

Technical information

Tooling

Standard contacts

Contact size	Part number	Head	Handles	Extraction tools
#20 1mm	RM FC 24V8 -	S20RCM	SHANDLES	RX20D44
	RM FC 20V8 -			
	RM FC 18V8 -			
	SM 24V8S-(1) SC 24V8S-(1)	S20SCM20		
	SM 24VL3S-(2) SC 24VL3S-(2)			
	SM SC 20V8S-(1) SM SC 20VL3S-(2)			
#16 1.6mm	RM FC 28M-	S16RCM20		
	RM FC 24M8-			
	RM FC 20M13-			
	RM FC 20M12-			
	RM FC 16M23-	S16RCM16		
	RM FC 14M80-	S16RCM14		
	SM SC 24M1- SM SC 24M1.1-	S16SCM20		
	SM SC 20M1- SM SC 20M1.1-			
	SM SC 16M1- SM SC 16M1.1-	S16SCM1		
	SM SC 14M1- SM SC 14M1.1-			
	SM SC 16M11- SM SC 16M1.11-	S16SCM11		

(1) contact reeled (2) loose contact

Note: endurance of SHANDLES tool = 5,000 cycles.

Contact size	Part number	Tool with separate locator			Extraction tools
		Hand tool	Positioner + locator setting		
#8 3.6mm	8291 3601A / 8291 3600A	MB17	VGE10078A	3	51060210936
	8291 3603A / 8291 3602A			3	
	8291 3605A / 8291 3604A			4	
	8291 3607A / 8291 3606A			5	
	8291 3609A / 8291 3608A			6/7	

Specific contacts

Contact size	Part number	Hand tools (SHANDLES) head	Tool with separate locator			Extraction tools		
			Hand tool	Positioner + locator setting				
#16 Ø 1.6mm Longer RM contact	RM28M1GE1-	S16RCM20	M860	M86186	6/8			
	RM24M8GE1-							
	RM20M13GE1-							
	RM16M23 GE1-	S16RCM16						
	RM14M60 GE1-	S16RCM1450				MB17	UH25	3
	RM14M80 GE1-	S16RCM14						
#16 Ø 1.6mm Shorter RC contact	RC28M1GE7-	S16RCM20	M860	M86164G	4/6			
	RC24M8GE7-				5/6			
	RC20M13GE7- RC20M12GE7-				5/7			
	RC16M23GE7-	S16RCM16			MB17	UH25	6/8	
	RC14M60GE7-	S16RCM1450						
	RC14M80GE7-	S16RCM14						
							3	

UTS Series Contacts

Contact selector guide

Contact preloaded

Electrical characteristics: contact resistance		
#20 Ø1mm	Machined	< 4mΩ
#16 Ø1.6mm	Machined	< 3mΩ

Available platings (contact preloaded)
Min 0.4µ gold over 2µ Ni

Contact supplied separately

Electrical characteristics: contact resistance		
#20 Ø1mm	Machined	< 6mΩ
	Stamped & formed	< 15mΩ
#16 Ø1.6mm	Machined	< 3mΩ
	Stamped & formed	< 6mΩ
#12 Ø2.4mm	Machined	< 5mΩ
#8 Ø3.6mm	Machined	< 5mΩ

Available platings (contact supplied separately)	
A	2µ Ni + 2µ Ag
J	Gold flash over 2µ Ni
K	Min 0.4µ gold over 2µ Ni
S31	Active part: Gold flash over Ni Crimp area: Nickel
S18	Active part: 0.75µ gold min over 2µ Ni Crimp area: 1.3µ tin over Ni Other: Nickel
S25 S26	Active part: 0.75µ Au over Ni Crimp area: flash Au over Ni
T	T: 2µm Ni mini all over + 3 to 5 µm Sn all over
TK6	2-5µ Sn pre-plated

Packaging

Conscious of the wide variety of applications, contact packaging has been considered for small series (bulk packaging) and high volume production (reeled contacts):

Size contacts #20 & #16



- 25 pieces loose packing (stamped & formed contacts)



- 50 pieces bulk packing (machined contacts)



- 1000 pieces bulk packing (machined contacts)



- 3000 pieces reeled (stamped & formed contacts)



- 5000 pieces reeled (machined contacts)

Size contacts #8



- 100 pieces bulk packing (stamped & formed contacts)

UTS Series

Contacts

Crimp contacts

Standard version



Contact size	Type	Wire size		Part number		Max wire Ø	Max insulator Ø	Plating available
		AWG	mm ²	Male	Female			
#20 Ø0.03	Machined	26-24	0.13-0.20	FM24VØK	FC24VØK		0.06" max	K
	Stamped & Formed	26-24	0.13-0.25	SM24VØ- (1)	SC24VØ- (1)		0.03"-0.06"	TK6 S25 (female) S26 (male)
				SM24VL3- (2)	SC24VL3- (2)			
	Machined	22-20	0.32-0.52	FM20VØK	FC20VØK		0.06" max	K
	Stamped & Formed	22-20	0.35-0.5	SM20VØ- (1)	SC20VØ- (1)		0.04"-0.08"	TK6 S25 (female) S26 (male)
SM20VL3- (2)				SC20VL3- (2)				
Machined	20-18	0.50-0.93	FM18VØK	FC18VØK		0.08" max	K	
#16 Ø0.06"	Machined	30-28	0.05-0.08	FM28MI-	FC28MI-	0.02"	0.04"	K, J, T
	Machined	26-24	0.13-0.2	FM24MØ-	FC24MØ-	0.03"	0.06"	K, J, T
	Stamped & Formed	26-24	0.13-0.25	SM24MI- (1)	SC24MI- (1)	0.03"-0.05"	Insulation grip	S31, S18, TK6
				SM24ML1- (2)	SC24ML1- (2)			
	Machined	22-20	0.32-0.52	FM20MI3-	FC20MI3-	0.04"	0.07"	K, J, T
				FM20MI2-	FC20MI2-		0.08"	
	Stamped & Formed	22-20	0.35-0.5	SM20MI- (1)	SC20MI- (1)	0.04"-0.81"	Insulation grip	S31, S18, TK6
				SM20ML1- (2)	SC20ML1- (2)			
	Machined	20-16	0.52-1.5	FM16MØ3-	FC16MØ3-	0.07"	0.12"	K, J, T
	Stamped & Formed	18-16	0.8-1.5	SM16MI- (1)	SC16MI- (1)	0.11"	No insulation grip	S31, S18, TK6
				SM16ML1- (2)	SC16ML1- (2)			
Stamped & Formed	18-16	0.8-1.5	SM16MI1- (1)	SC16MI1- (1)	0.07"-0.11"	Insulation grip	S31, S18, TK6	
			SM16ML11- (2)	SC16ML11- (2)				
Machined	16-14	1.5-2.5	FM14MØ0-	FC14MØ0-	0.08"	0.12"	K, J, T	
Machined	16-14	1.5-2.5	FM14MØ0-	FC14MØ0-	0.08"	0.12"	K, J, T	
Stamped & Formed	14	2.0-2.5	SM14MI- (1)	SC14MI- (1)	0.12"	No insulation grip	S31, S18, TK6	
			SM14ML1- (2)	SC14ML1- (2)				
#8 Ø0.14"	Machined	16	1.5	82913601A	82913600A	-	0.25"	A
		14	2.5	82913603A	82913602A			
		12	4	82913605A	82913604A			
		10	6.0	82913607A	82913606A			
		8	10.0	82913609A	82913608A			

(1) contact reeled (2) loose contact

Example: FM24VØK - Size #20, Machined, AWG24 wire.

UTS Series

Stage - Light

Building automation & control



Industry

Off road - Mining
Railway

Medical



SOURIAU

www.souriau-industrial.com

technicalsupport@souriau.com

Esterline
Connection Technologies