

REVISIONS				
P	LTN	DESCRIPTION	DATE	APVD
A		RELEASED PER ECO-19-014774	26SEP2019	CJV JW
B		REVISED PER ECN-21-126523	14MAR2022	TX DZ
C		REVISED PER ECN-22-152380	09MAY2022	TX DZ
C1		REVISED PER ECN-23-222537	19JUL2023	JG DZ

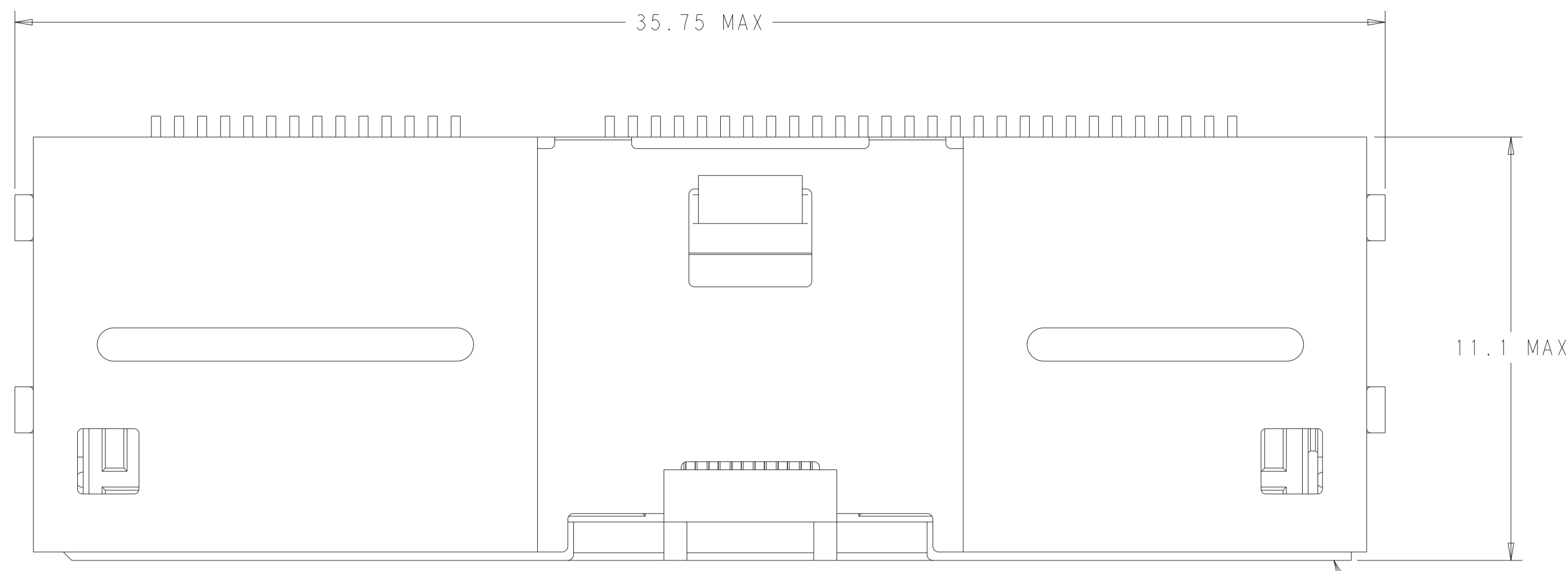

- 1 HOUSING, ORGANIZERS, CONTACT OVERMOLDS - LCP, UL94V-0, BLACK. SHELL, CONTACTS AND HOLD DOWNS - COPPER ALLOY.
- 2 CONTACTS - GOLD PLATE ON MATING SURFACES, TIN PLATE ON SOLDER FEET. HOLD DOWNS - TIN PLATE. SHELL - NICKEL PLATE, TIN PLATE ON HOLD DOWNS
- 3 DATUMS AND BASIC DIMENSIONS ESTABLISHED BY CUSTOMER.
- 4. MINIMUM HOST PCB THICKNESS: 1.5
- 5 SEE MSA SPECIFICATION FOR ADDITIONAL PADDLE CARD LAYOUTS COMPATIBLE WITH THIS RECEPTACLE AND FOR OPTIONAL SPLIT CONTACT PAD LAYOUTS FOR THE PADDLE CARD. SPECIFICATION PINOUT MAY ALSO DESIGNATE PAD SEQUENCE DIFFERENT FROM ILLUSTRATION.
- 6 POSITIONS DESIGNATED AS "SIGNAL" ARE REQUIRED LOCATIONS FOR HIGH SPEED DIFFERENTIAL PAIR SIGNALING. THESE LOCATIONS MAY ALSO BE USED FOR SUPPORTING SIDEBAND SIGNALS OR OTHER UTILITY PURPOSES. POSITIONS DESIGNATED AS "GROUND" ARE REQUIRED WHEN SUPPORTING HIGH SPEED DIFFERENTIAL SIGNALS. THESE LOCATIONS MAY ALSO BE USED FOR SIDEBAND SIGNALS OR OTHER UTILITY PURPOSES.
- 7 COMPONENT AND TRACES KEEP OUT AREA. EACH EDGE 0.15 MIN FROM EDGE OF HOLE.
- 8 TAPE AND REEL PACKAGED FOR PICK AND PLACE SURFACE MOUNT PROCESSING, SEE FIGURE 1. POCKET TAPE WIDTH = 56.

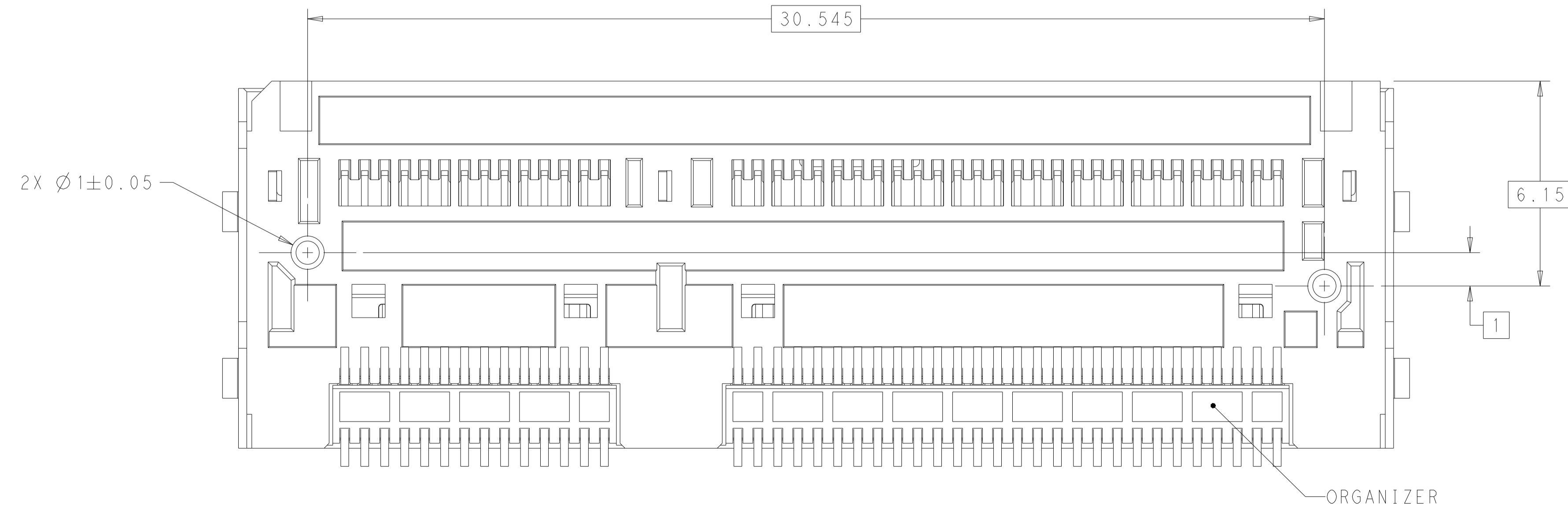
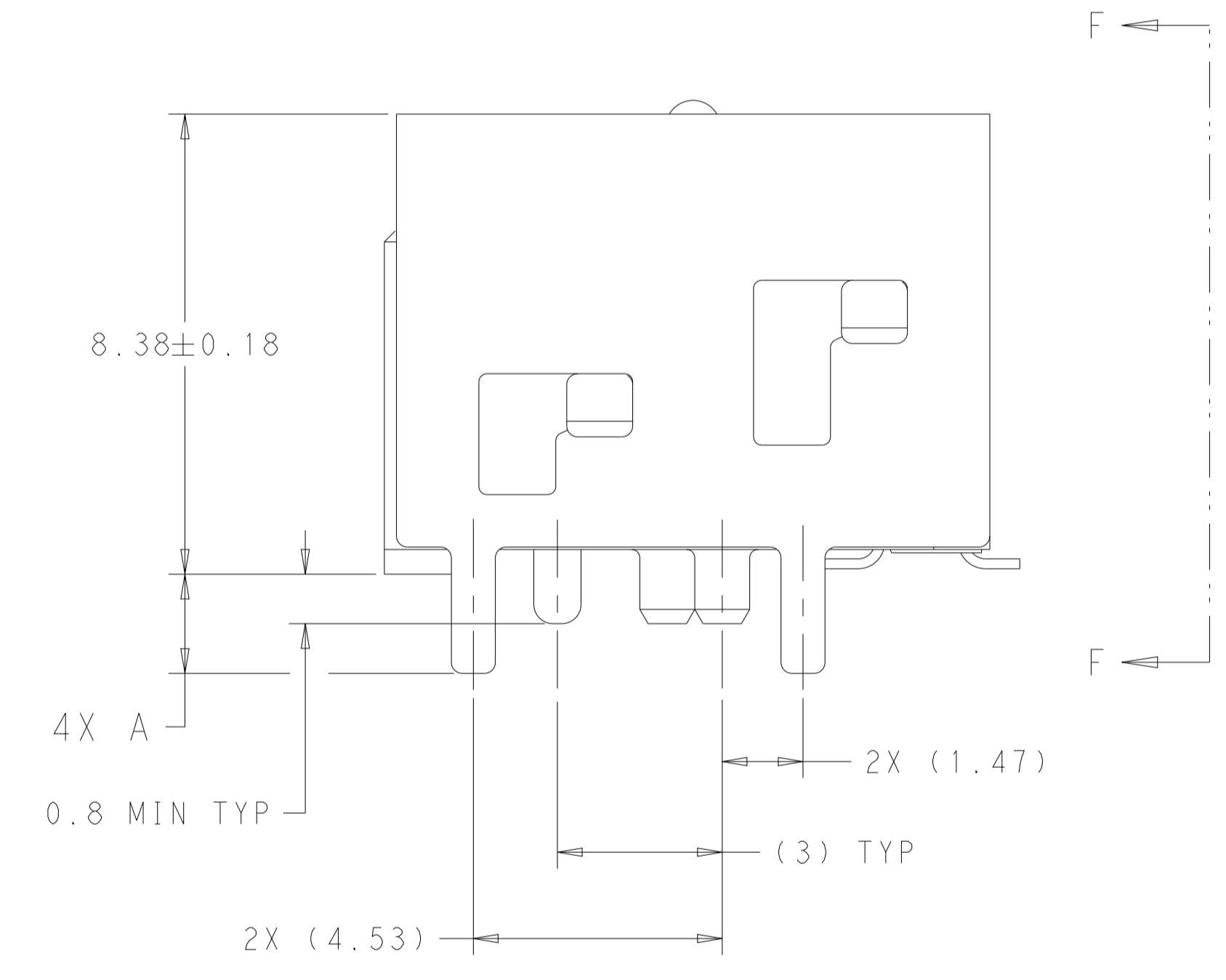
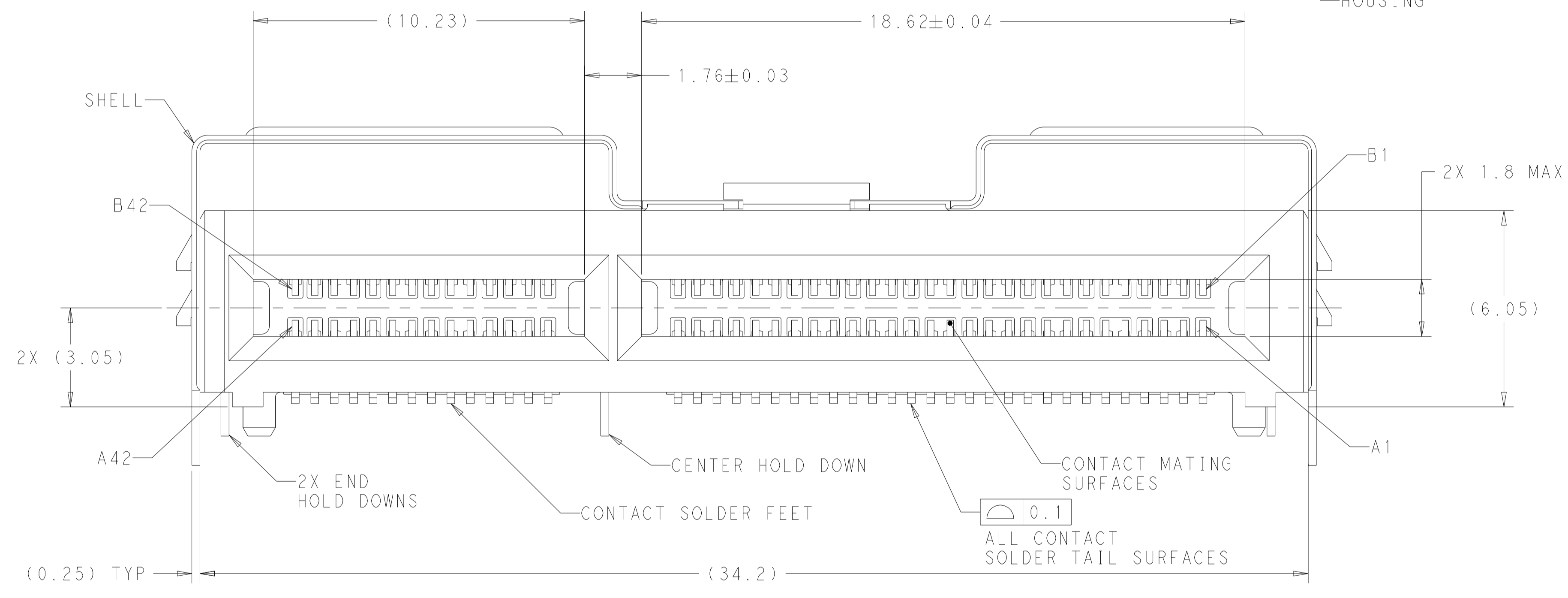

SEE SHEET 5 FOR PART TABLE

THIS DRAWING IS A CONTROLLED DOCUMENT.		OWN: B. MATTHEWS 12MAR2018	TE Connectivity
DIMENSIONS: mm		CHK: D. HARMON 12MAR2018	
TOLERANCES UNLESS OTHERWISE SPECIFIED:		APVD: D. HARMON 12MAR2018	NAME: RECEPTACLE ASSEMBLY, RIGHT ANGLE, 84 POSITION, SLIVER 2.0
0 PLC ±	1 PLC ±	PRODUCT SPEC: 108-130021	SIZE: A1
2 PLC ±	3 PLC ±	APPLICATION SPEC: 114-130015	CAGE CODE: -
4 PLC ±	ANGLES ±	WEIGHT: -	DRAWING NO: C=2331814
MATERIAL: △	FINISH: △	CUSTOMER DRAWING	RESTRICTED TO: -
SCALE: 10:1			SHEET: 1 OF 6
REV: C1			

REVISIONS				
P	LTN	DESCRIPTION	DATE	APVD
-		SEE SHEET 1	-	-

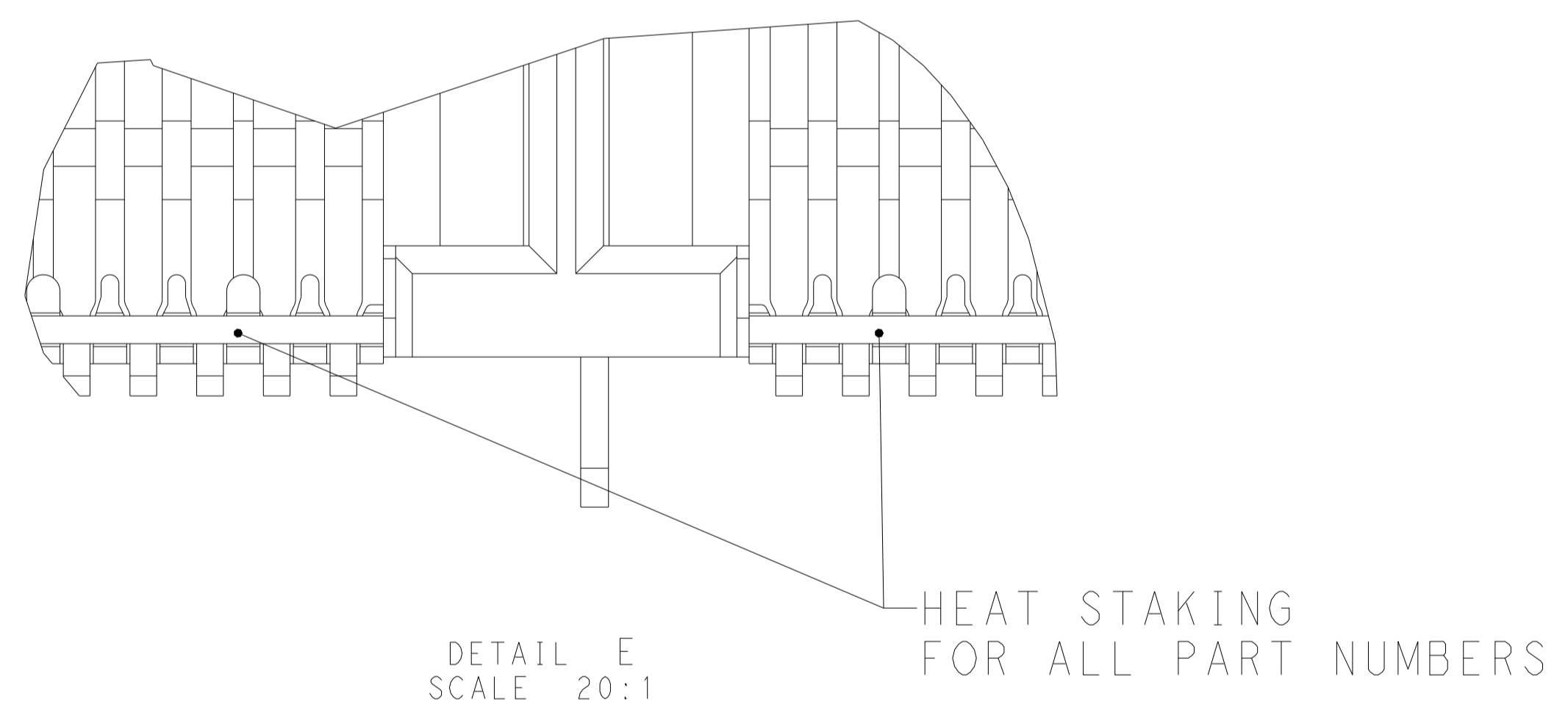
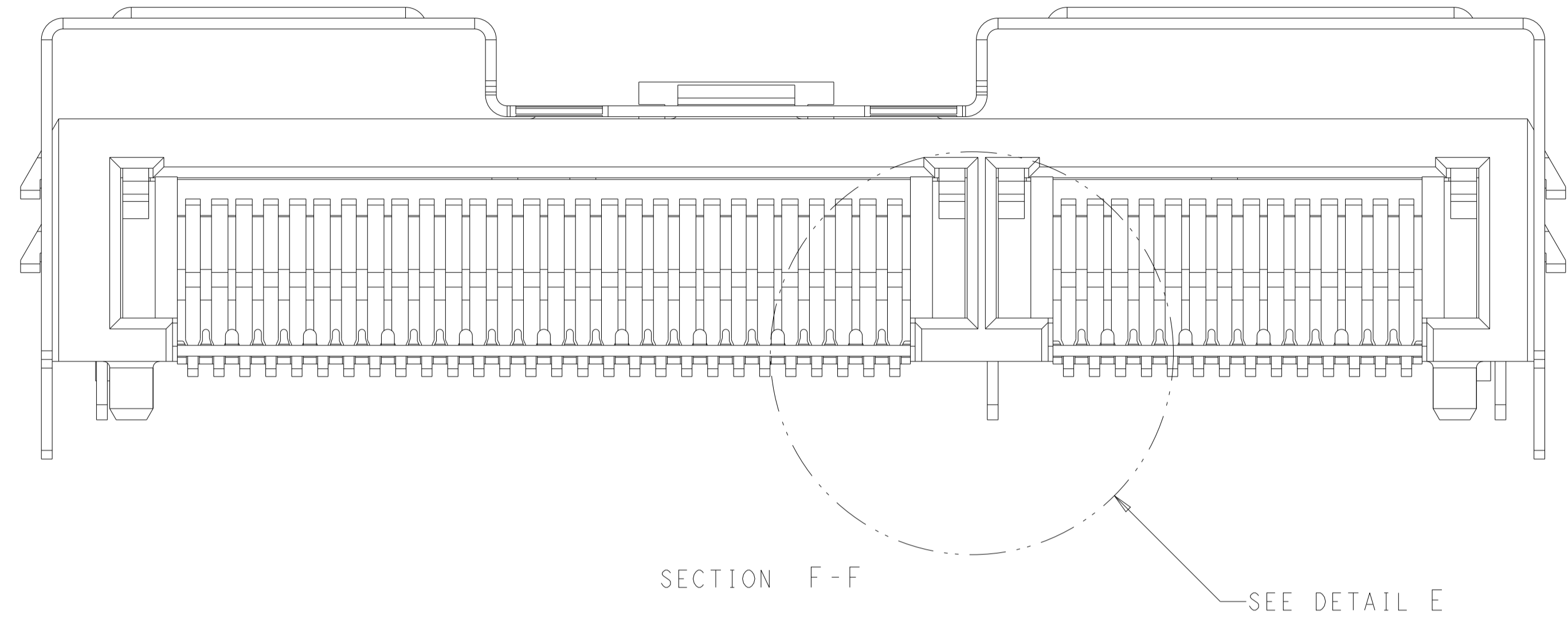

THIS DRAWING IS A CONTROLLED DOCUMENT.		DWN B. MATTHEWS 12MAR2018 CHK D. HARMON 12MAR2018 APVD D. HARMON 12MAR2018		NAME RECEPTACLE ASSEMBLY, RIGHT ANGLE, 84 POSITION, SLIVER 2.0 PRODUCT SPEC 108-130021 APPLICATION SPEC -
DIMENSIONS: mm 	TOLERANCES UNLESS OTHERWISE SPECIFIED: 0 PLC ±. 1 PLC ±. 2 PLC ±. 3 PLC ±. 4 PLC ±. ANGLES ±. FINISH	SIZE A1 CAGE CODE - DRAWING NO. C=2331814 WEIGHT - CUSTOMER DRAWING		

REVISIONS				
P	LTN	DESCRIPTION	DATE	APPV
-	-	SEE SHEET 1	-	-

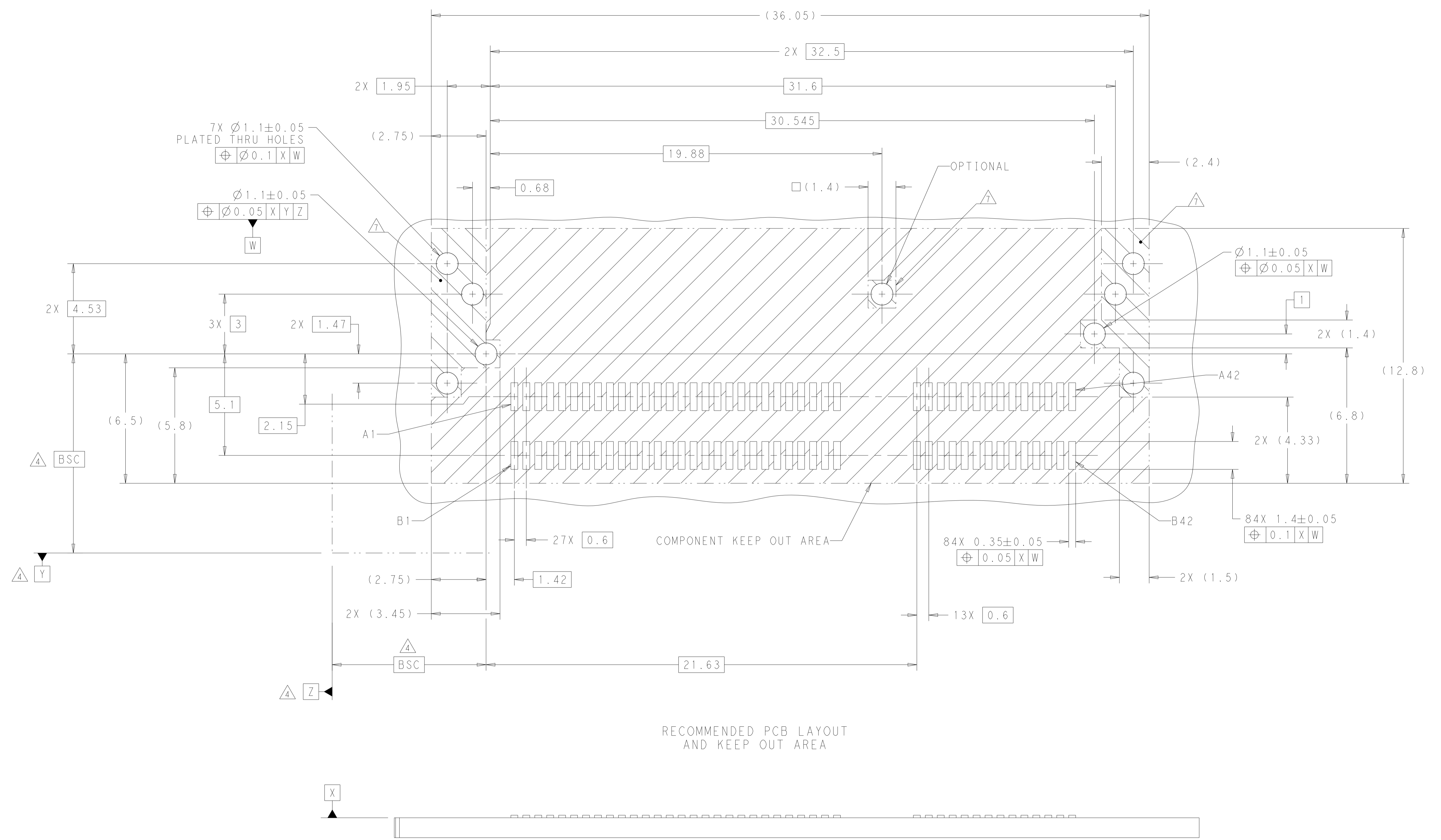

RECOMMENDED PCB LAYOUT
 AND KEEP OUT AREA

THIS DRAWING IS A CONTROLLED DOCUMENT.		OWN: B. MATTHEWS 12MAR2018	TE Connectivity
DIMENSIONS: mm		CHK: D. HARMON 12MAR2018	
TOLERANCES UNLESS OTHERWISE SPECIFIED:		APVD: D. HARMON 12MAR2018	NAME: RECEPTACLE ASSEMBLY, RIGHT ANGLE, 84 POSITION, SLIVER 2.0
0 PLC ±	1 PLC ±	PRODUCT SPEC	SIZE: A1
2 PLC ±	3 PLC ±	APPLICATION SPEC	CAGE CODE: -
4 PLC ±	ANGLES ±	114-130015	DRAWING NO: C=2331814
MATERIAL:	FINISH:	WEIGHT:	RESTRICTED TO:
CUSTOMER DRAWING		SCALE: 1:1	SHEET 3 OF 6 REV: C1

REVISIONS				
P	LTN	DESCRIPTION	DATE	APVD
-	-	SEE SHEET 1	-	-

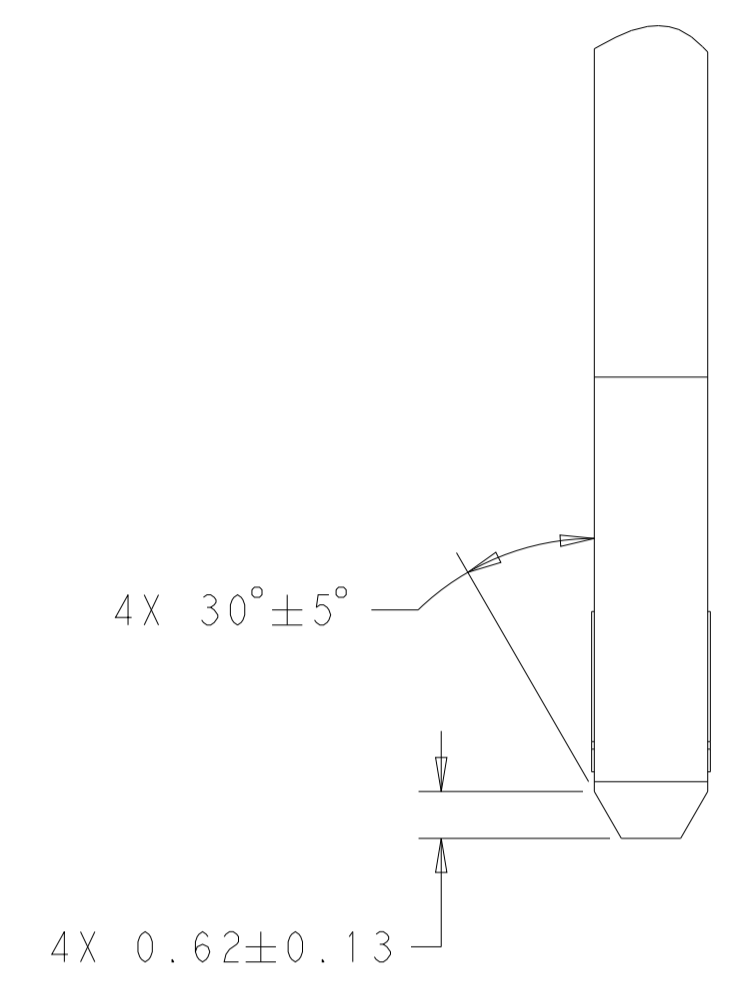
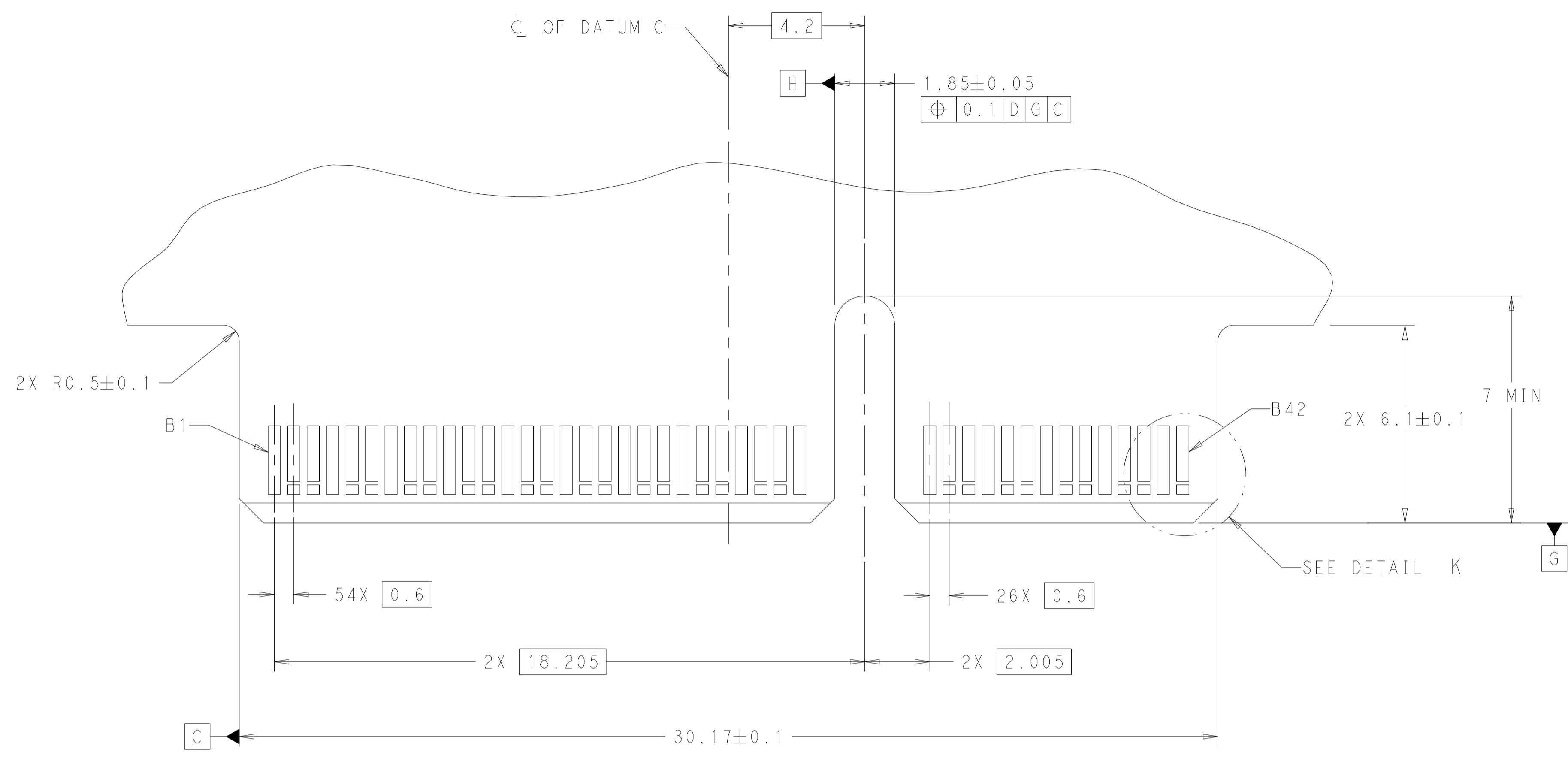

RECOMMENDED PCB OUTLINE DIMENSIONS
 TOLERANCE VALUES ARE CRITICAL. PLEASE BE SURE TO DESIGNATE
 TOLERANCES TO PCB SUPPLIER TO ENSURE OPTIMIZED FUNCTIONALITY

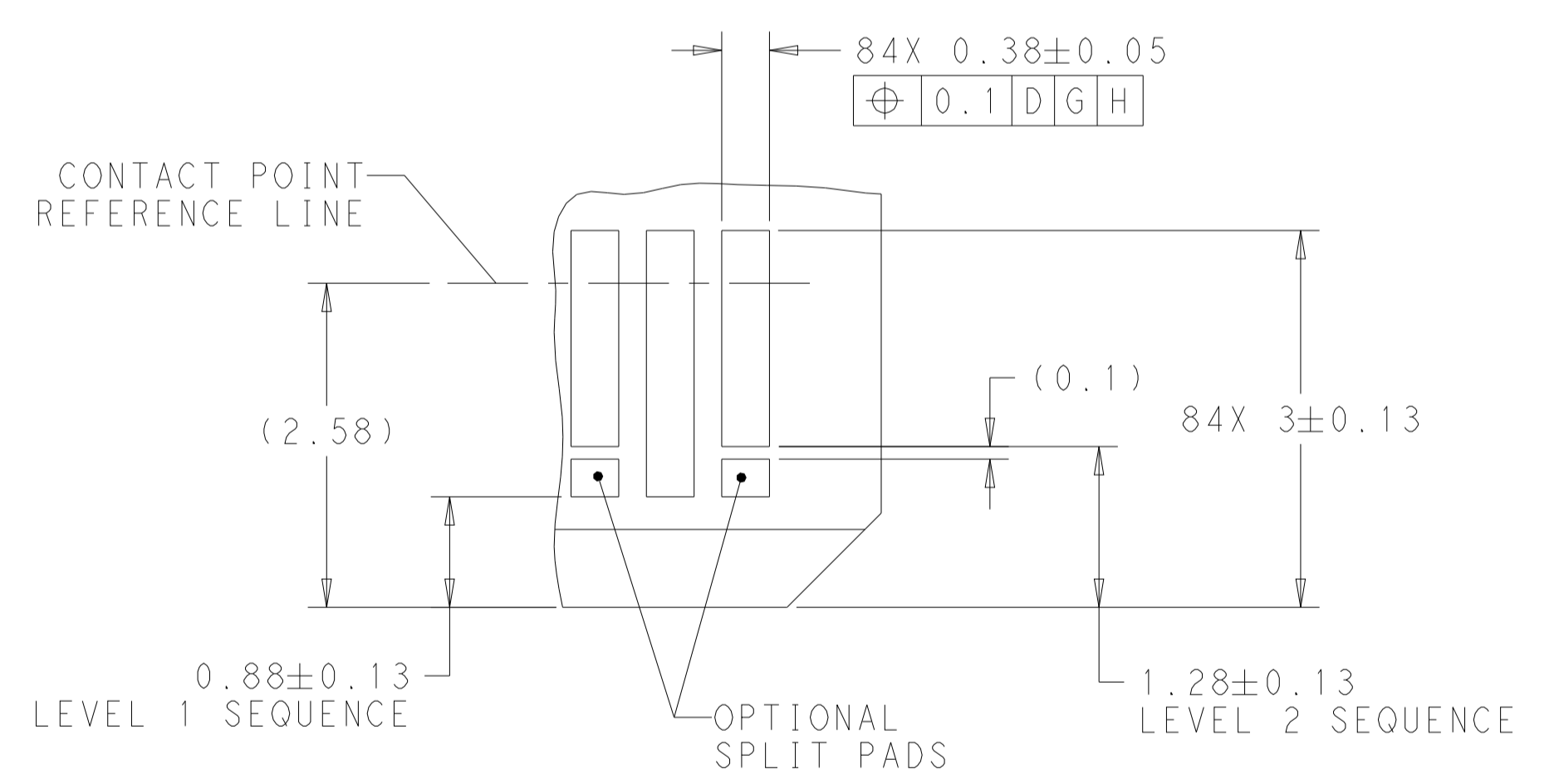
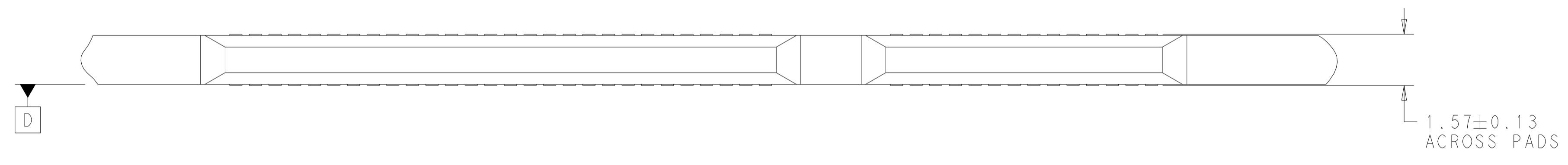

5 DETAIL K
 SCALE 20:1

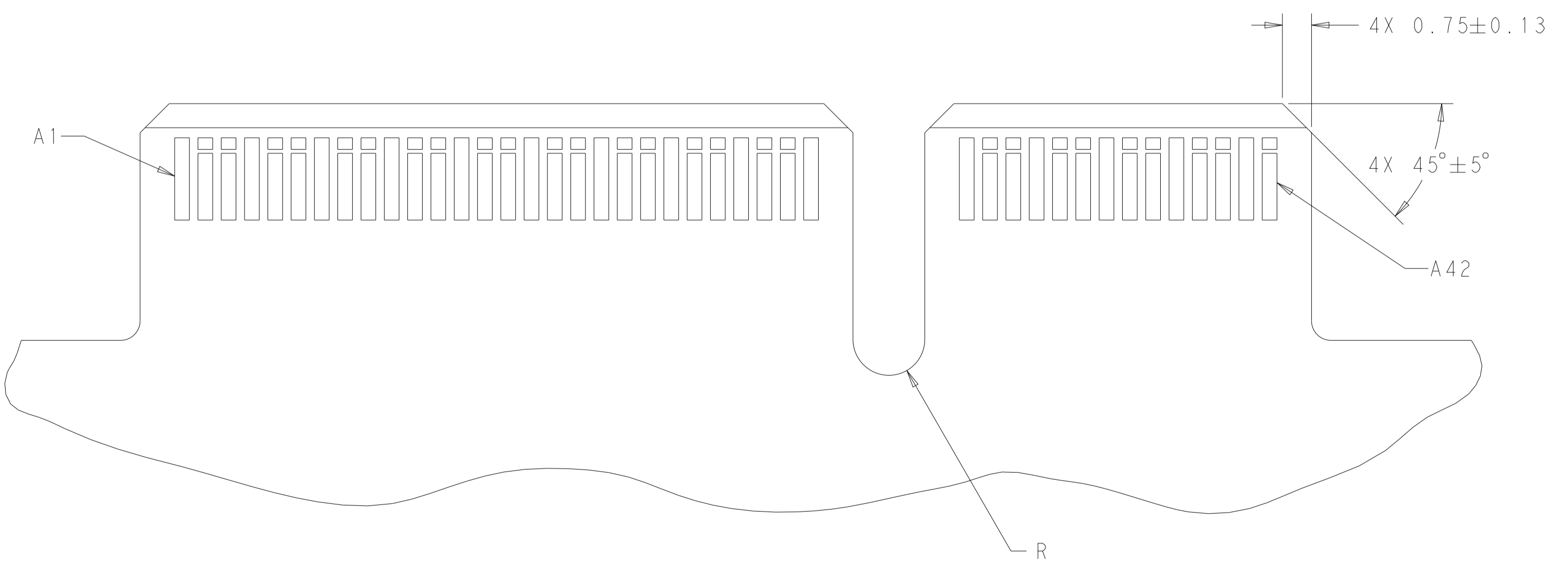

THIS DRAWING IS A CONTROLLED DOCUMENT.		OWN B. MATTHEWS 12MAR2018	TE Connectivity
DIMENSIONS: mm		CHK D. HARMON 12MAR2018	
		APVD D. HARMON 12MAR2018	NAME RECEPTACLE ASSEMBLY, RIGHT ANGLE, 84 POSITION, SLIVER 2.0
TOLERANCES UNLESS OTHERWISE SPECIFIED:		PRODUCT SPEC 108-130021	SIZE A1
0 PLC ± 1 PLC ± 2 PLC ± 3 PLC ± 4 PLC ± ANGLES ±		APPLICATION SPEC 114-130015	CAGE CODE C=2331814
MATERIAL FINISH		WEIGHT	RESTRICTED TO
CUSTOMER DRAWING		SCALE 1:1	SHEET 4 OF 6 REV C1

TABLE 1: CONNECTOR CONTACT IDENTIFICATION

CONTACT NUMBER	SIDE A	SIDE B
1	GROUND	GROUND
2	SIGNAL	SIGNAL
3	SIGNAL	SIGNAL
4	GROUND	GROUND
5	SIGNAL	SIGNAL
6	SIGNAL	SIGNAL
7	GROUND	GROUND
8	SIGNAL	SIGNAL
9	SIGNAL	SIGNAL
10	GROUND	GROUND
11	SIGNAL	SIGNAL
12	SIGNAL	SIGNAL
13	GROUND	GROUND
14	SIGNAL	SIGNAL
15	SIGNAL	SIGNAL
16	GROUND	GROUND
17	SIGNAL	SIGNAL
18	SIGNAL	SIGNAL
19	GROUND	GROUND
20	SIGNAL	SIGNAL
21	SIGNAL	SIGNAL
22	GROUND	GROUND
23	SIGNAL	SIGNAL
24	SIGNAL	SIGNAL
25	GROUND	GROUND
26	SIGNAL	SIGNAL
27	SIGNAL	SIGNAL
28	GROUND	GROUND
29	GROUND	GROUND
30	SIGNAL	SIGNAL
31	SIGNAL	SIGNAL
32	GROUND	GROUND
33	SIGNAL	SIGNAL
34	SIGNAL	SIGNAL
35	GROUND	GROUND
36	SIGNAL	SIGNAL
37	SIGNAL	SIGNAL
38	GROUND	GROUND
39	SIGNAL	SIGNAL
40	SIGNAL	SIGNAL
41	GROUND	GROUND
42	GROUND	GROUND

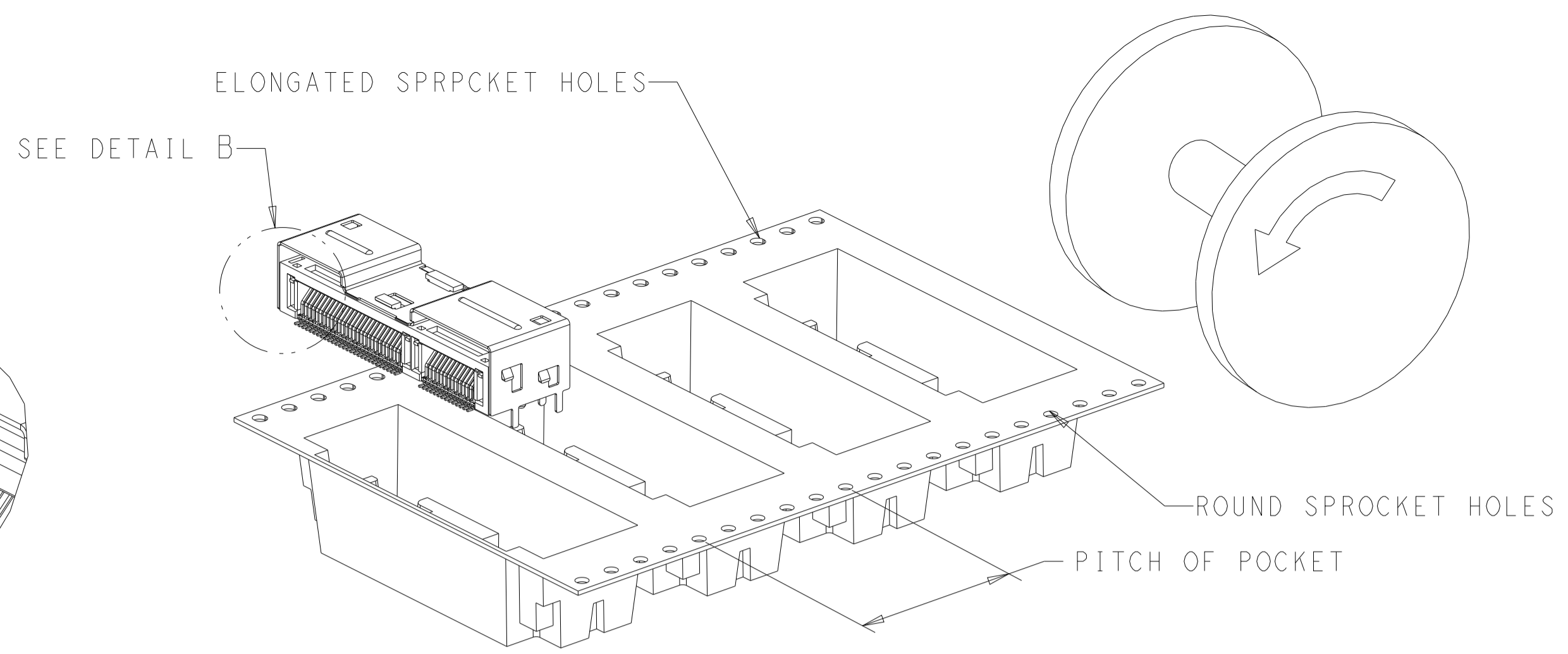
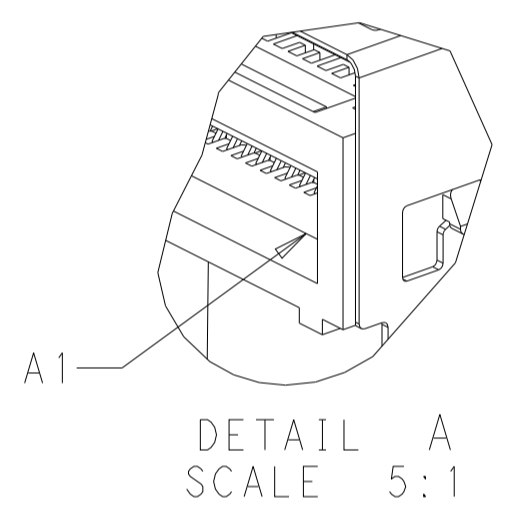
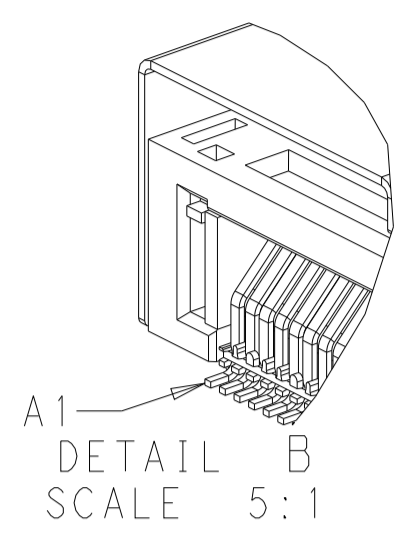

FIGURE 1
DIRECTION OFF TOP OF REEL
FOR USER UNREELING
FOR 2331814-1, 2331814-2
2331814-4 TO 2331814-9
SCALE 2:1

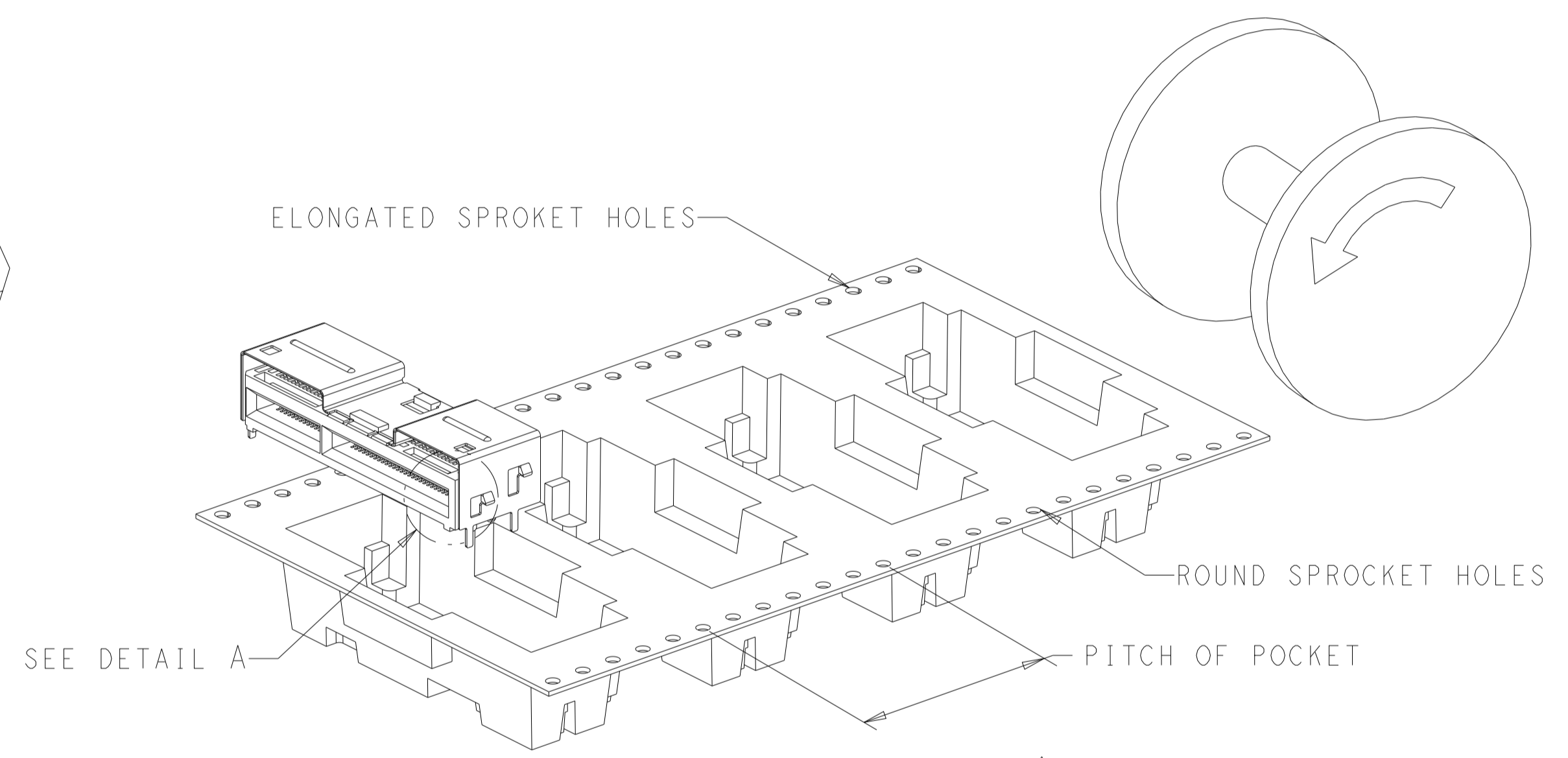
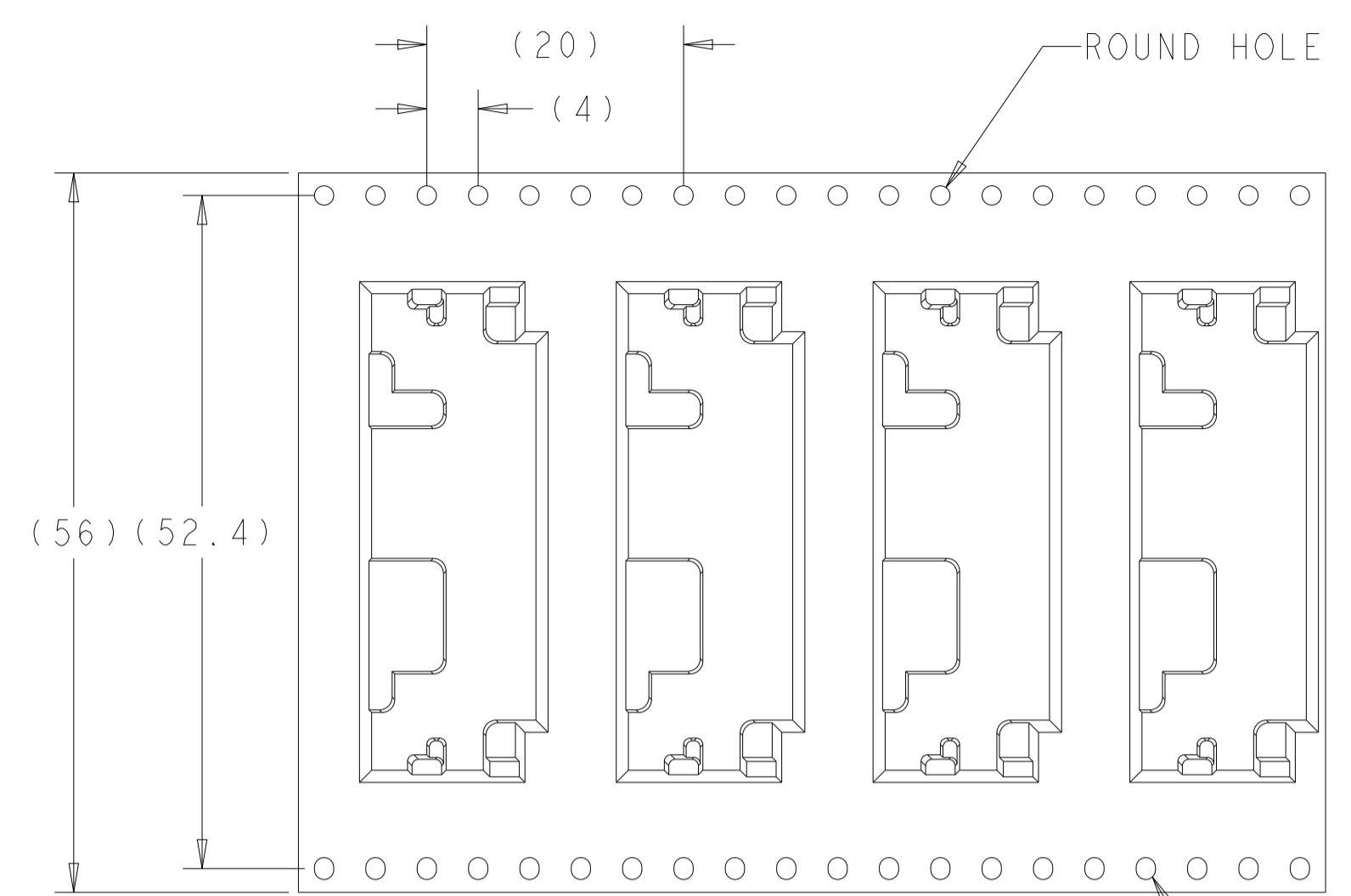
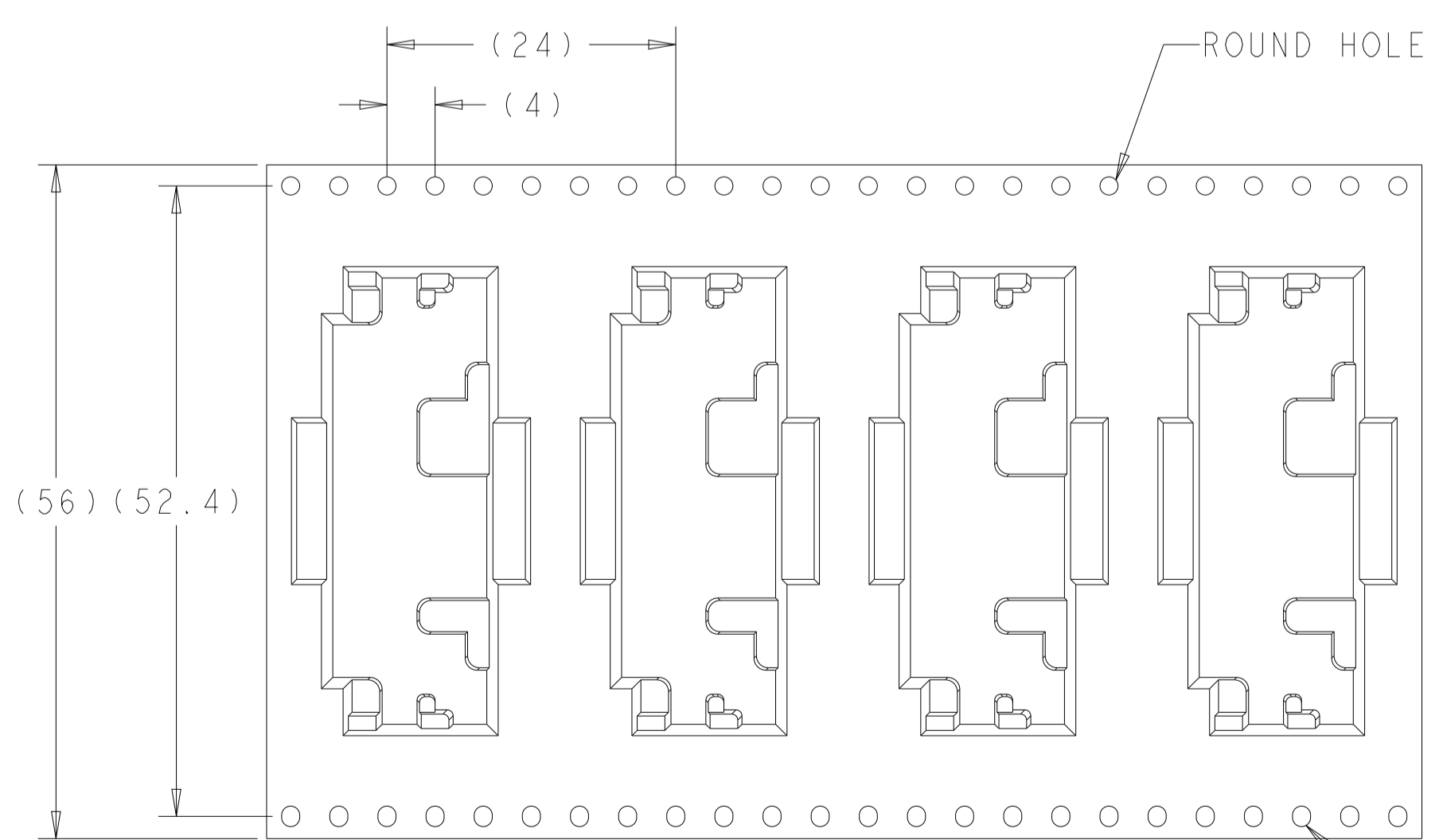

FIGURE 2
DIRECTION OFF TOP OF REEL
FOR USER UNREELING
FOR 1-2331814-1 TO 1-2331814-9
SCALE 2:1



FOR 2331814-1, 2331814-2
2331814-4 TO 2331814-9
SCALE 2:1



FOR 1-2331814-1 TO 1-2331814-9
SCALE 2:1

PLATING	POCKET TAPE PITCH	REEL QUANTITY	MATING CYCLES	PART NUMBER
1.2±0.2	ALL	0.76µm Au 0.38µm Au FLASH Au/PdNi	24	300
1.8 ^{+0.2/-0.1}	ENDS	0.76µm Au 0.38µm Au FLASH Au/PdNi	24	300
1.8 ^{+0.2/-0.1}	ALL	0.76µm Au 0.38µm Au FLASH Au/PdNi	24	300
1.2±0.2	ALL	0.76µm Au 0.38µm Au FLASH Au/PdNi	20	350
1.8 ^{+0.2/-0.1}	ENDS	0.76µm Au 0.38µm Au FLASH Au/PdNi	20	350
1.8 ^{+0.2/-0.1}	ALL	0.76µm Au 0.38µm Au FLASH Au/PdNi	20	350

REVISIONS				
P. LTM	DESCRIPTION	DATE	OWN	APVD
-	SEE SHEET 1	-	-	-

THIS DRAWING IS A CONTROLLED DOCUMENT.

APVD: D. HARMON 12MAR2018
CHK: D. HARMON 12MAR2018
OWN: B. MATTHEWS 12MAR2018

TE Connectivity

RECEPTACLE ASSEMBLY, RIGHT ANGLE, 84 POSITION, SLIVER 2.0

SCALE 10:1 SHEET 5 OF 6 REV C1

REVISIONS				
P	LTN	DESCRIPTION	DATE	APVD
-		SEE SHEET 1	-	-

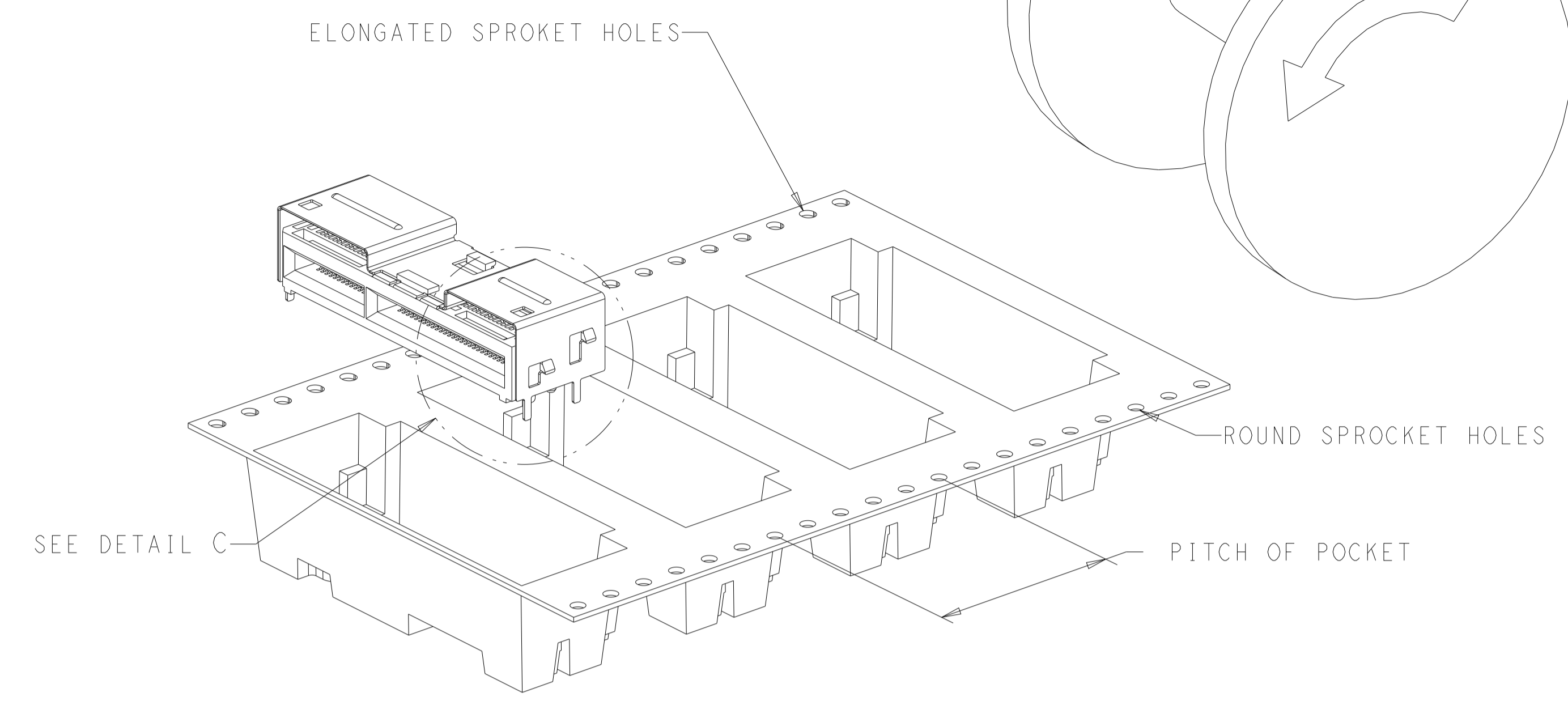
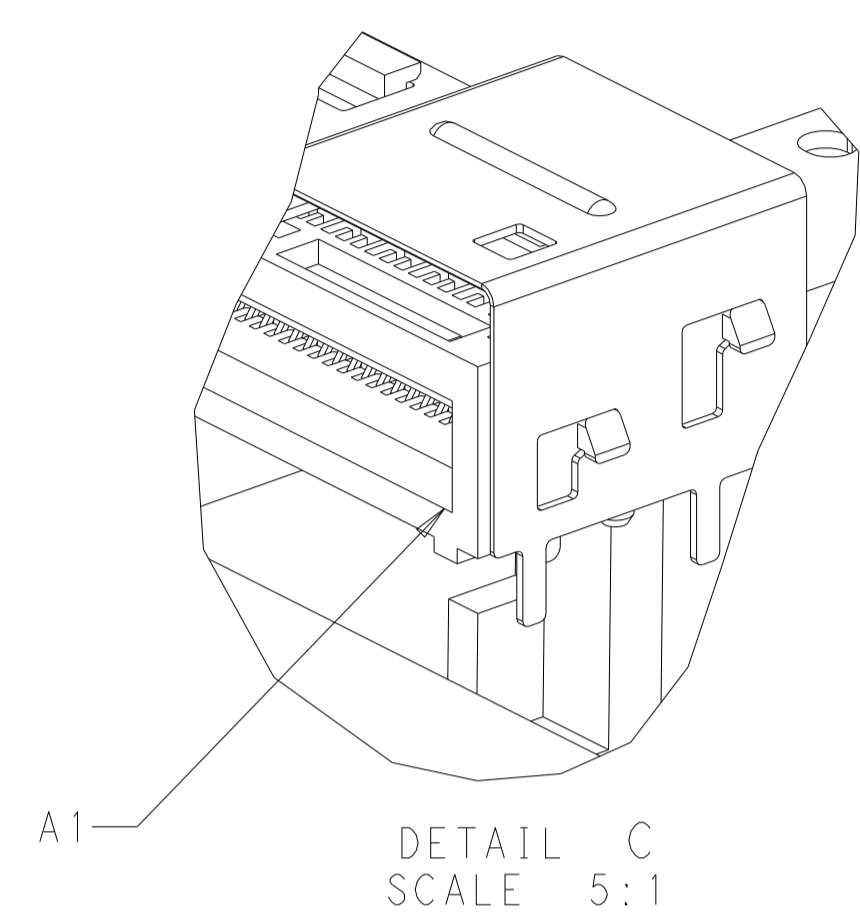
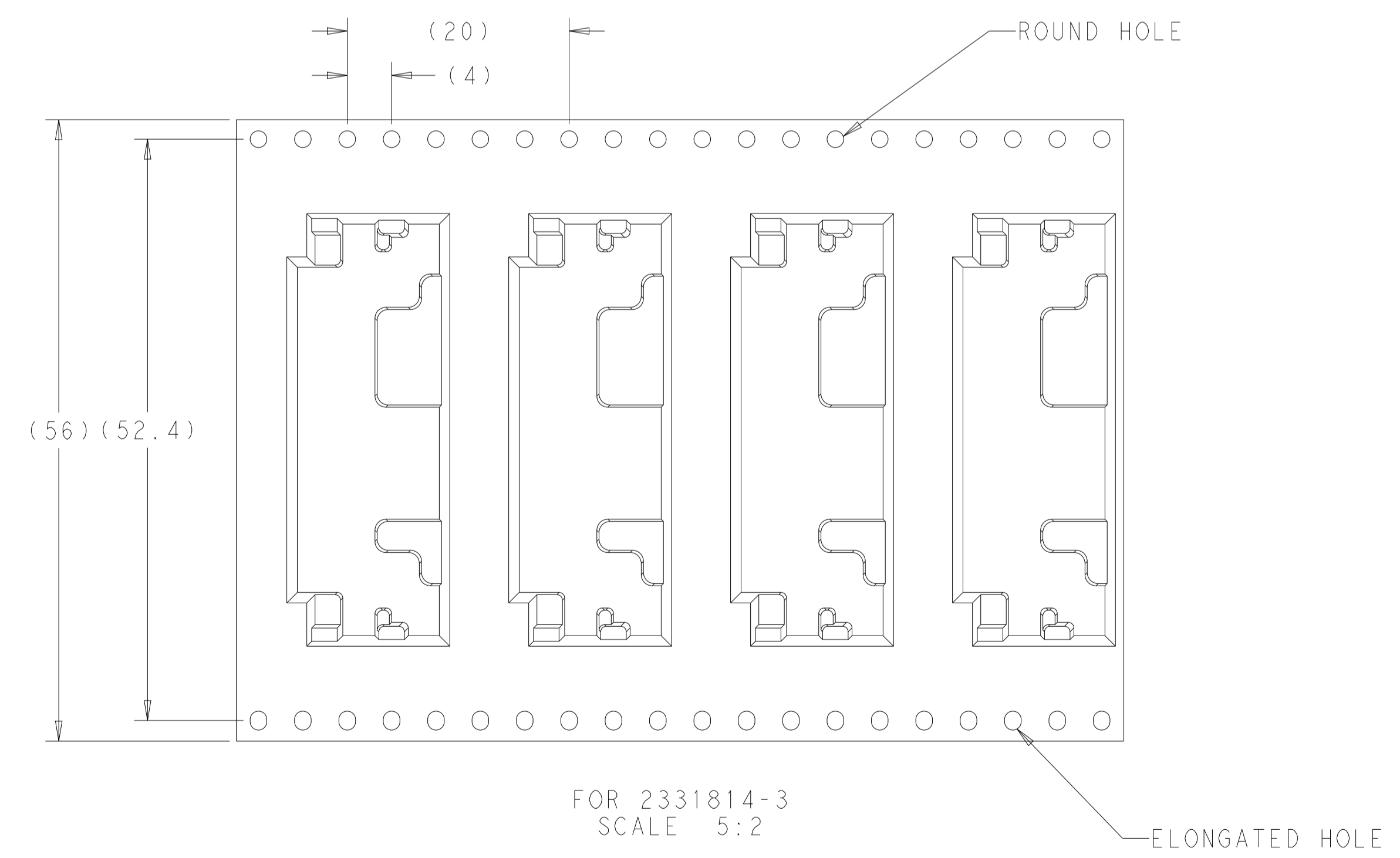

FIGURE 3
 DIRECTION OFF TOP OF REEL
 FOR USER UNREELING
 FOR 2331814-3
 SCALE 5:2



THIS DRAWING IS A CONTROLLED DOCUMENT.		OWN B. MATTHEWS 12MAR2018	TE Connectivity
DIMENSIONS:		CHK D. HARMON 12MAR2018	
mm	TOLERANCES UNLESS OTHERWISE SPECIFIED:	APVD D. HARMON 12MAR2018	NAME RECEPTACLE ASSEMBLY, RIGHT ANGLE, 84 POSITION, SLIVER 2.0
	0 PLC ± 1 PLC ± 2 PLC ± 3 PLC ± 4 PLC ± ANGLES ± FINISH ±	PRODUCT SPEC 108-130021 APPLICATION SPEC 114-130015	SIZE A1
MATERIAL		WEIGHT -	CAGE CODE -
CUSTOMER DRAWING		SCALE 10:1	DRAWING NO C=2331814
		SHEET 6	OF 6
		REV C1	