

Antenna Datasheet

TITLE : AN012400C00 SERIES
AN012400C00 シリーズ

1. 特徴 Features

- 無線 LAN、Bluetooth 等向け 2.4 – 2.5 GHz アンテナ
2.4 – 2.5-GHz Antenna for WLAN, Bluetooth, etc.
- 小型 Compact size
- 高効率 High efficiency
- 表面実装部品 Surface mount device
- エンボスリール梱包 Embossed reel package

2. 品名 Product name

単品 Single unit: AN012400C00

3200 個パッケージ 3200-piece package: AN012400C00R3200

3. 形状、寸法と重量 Shape, dimensions, and weight

3.1. 形状 Shape

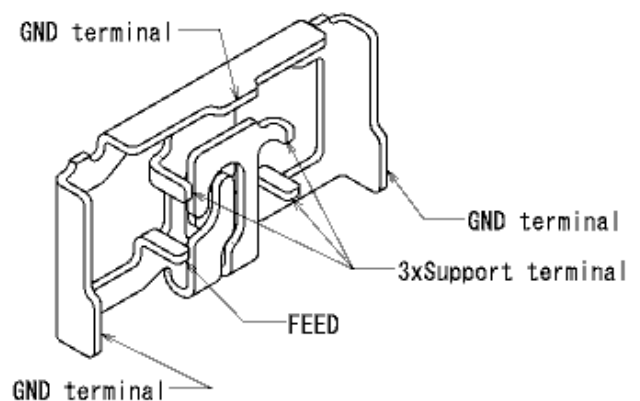
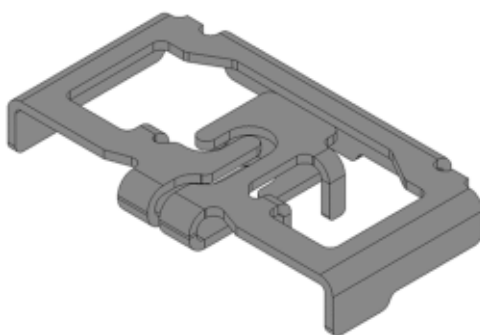

3.2. 寸法 Dimensions

12.5 (width) × 7.25 (depth) × 1.9 (height) mm

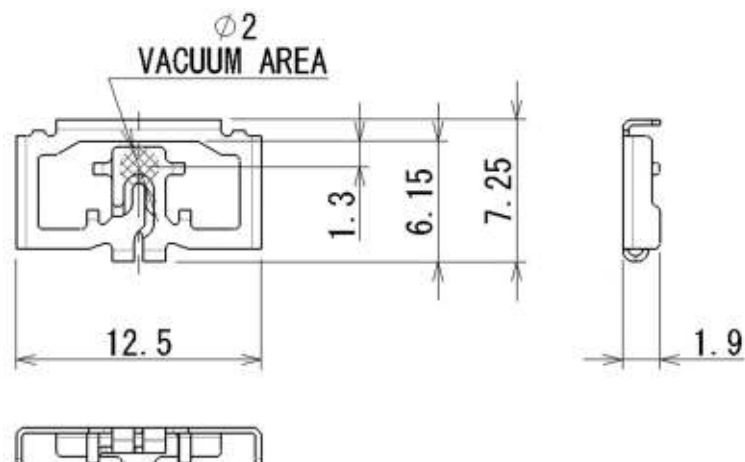

3.3. 重量 Weight

0.22 g (typical)

3.4. めっき Plating

なし None

3.5. 方式 Type

スプリットリング Split ring

3.6. 材料 Material

銅合金 Copper alloy

4. 高周波特性 RF characteristics

4.1. 周波数帯域 Frequency range

2.4 – 2.5 GHz

4.2. インピーダンス Impedance

50 Ω

4.3. Voltage standing wave ratio (VSWR)

50 x 30 mm の標準基板実装時の VSWR 特性例

VSWR characteristics of the antenna on a 50 × 30-mm reference board

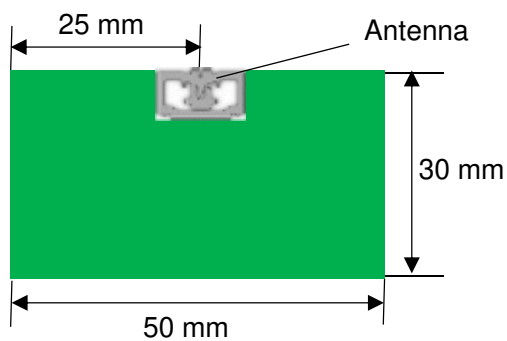

VSWR < 2.0 (frequency range: 2.4 – 2.5 GHz)

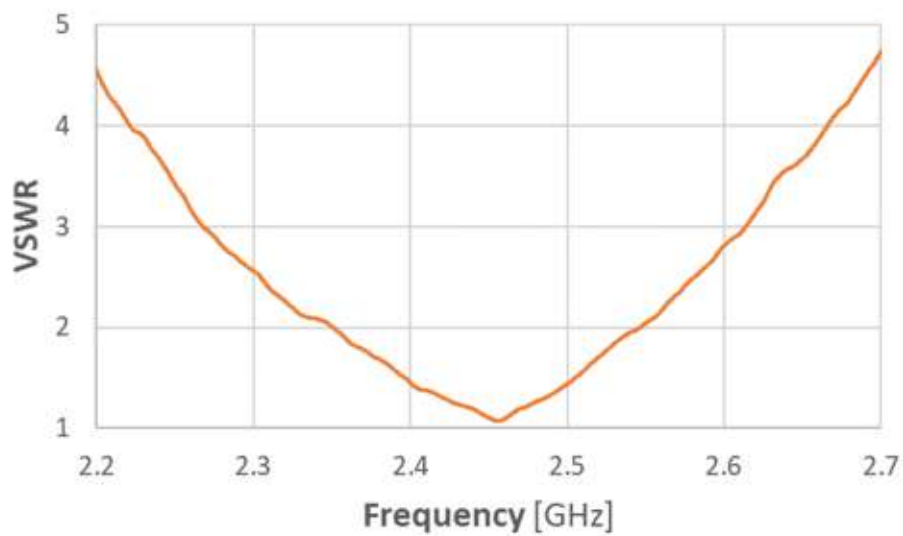

4.4 放射効率 Radiation efficiency

50 x 30 mm の標準基板実装時の放射効率特性例、ケーブル・配線損を除く

Radiation efficiency of the antenna mounted on a 50 × 30-mm reference board (excluding cable and feeder-line losses)

Radiation efficiency > 85 % (frequency range: 2.4 – 2.5 GHz)

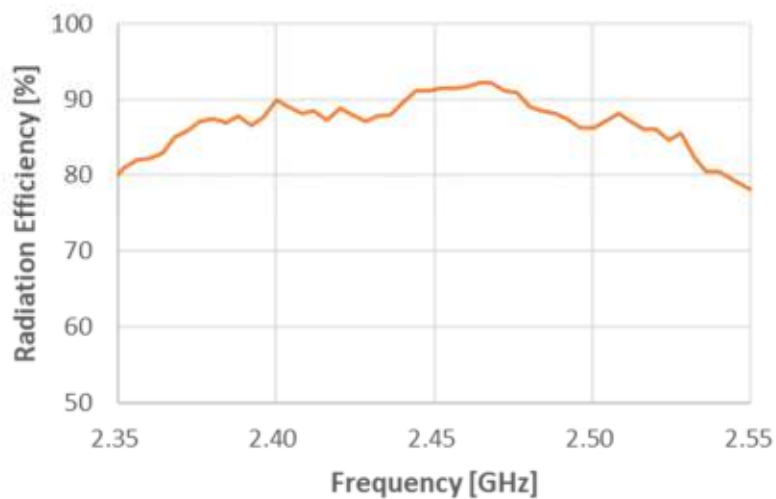

4.5. 放射パターン Radiation pattern:

50 x 30 mm の標準基板実装時の放射パターン特性例

Radiation pattern of the antenna mounted on a 50 × 30-mm reference board



Radiation pattern

2.45 GHz

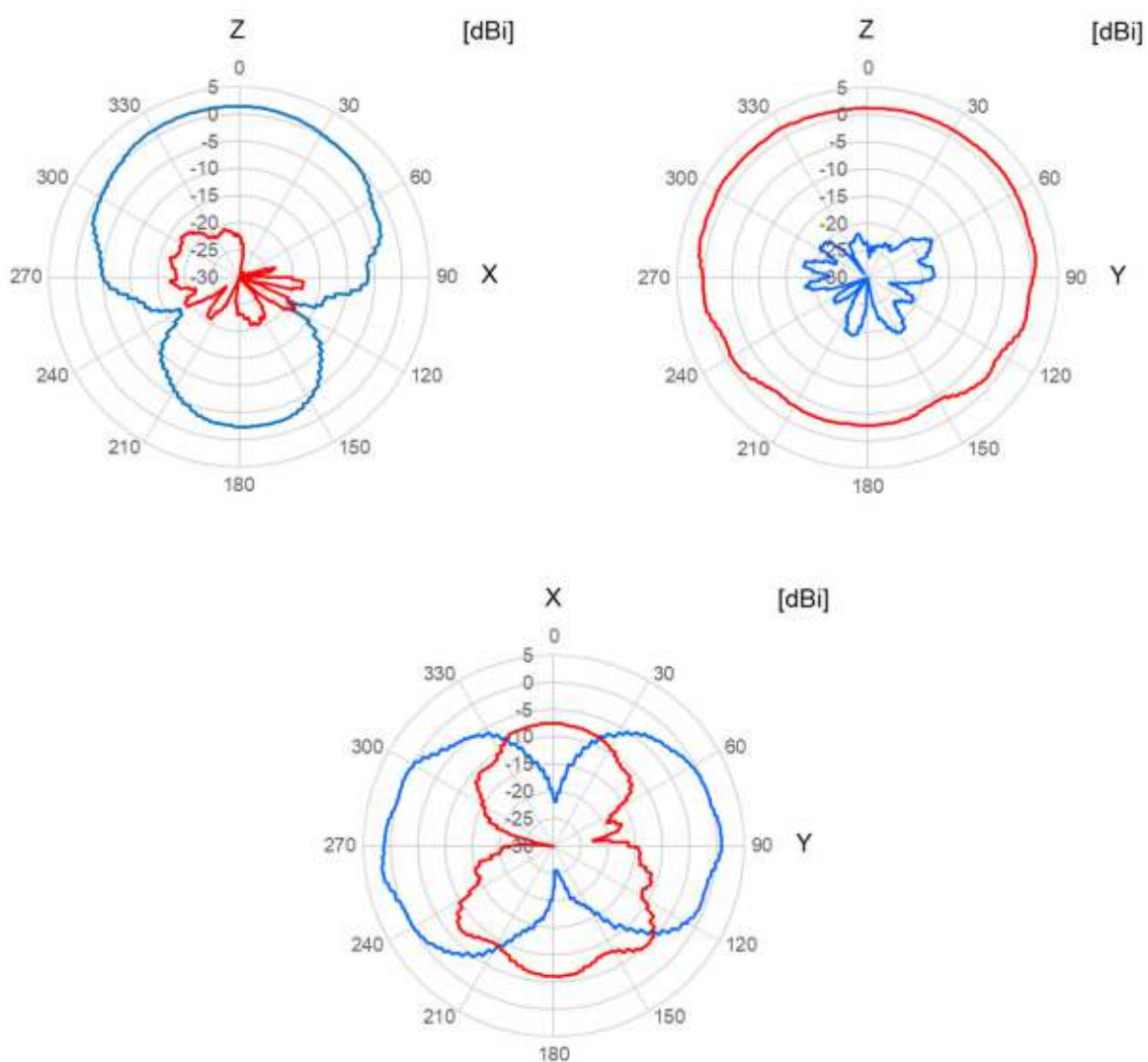

青線 Blue line: 水平偏波 Horizontal polarization

赤線 Red line: 垂直偏波 Vertical polarization



Peak gain of the main polarization component in the ZX, ZY, and XY Planes

Frequency [GHz]	Peak gain [dBi]
2.45	1.94

5. 環境条件 Environmental conditions

5.1. 使用温度範囲 Operating temperature range

-40 °C to +125 °C

5.2. 保存条件 Storage conditions

IEC 61760-2

保存温度 Stock temperature range

+5 °C to +40 °C

相对湿度 Relative humidity

10 % to 75 %

6. 推奨ランドパターンおよび推奨基板 Recommended land pattern and reference board

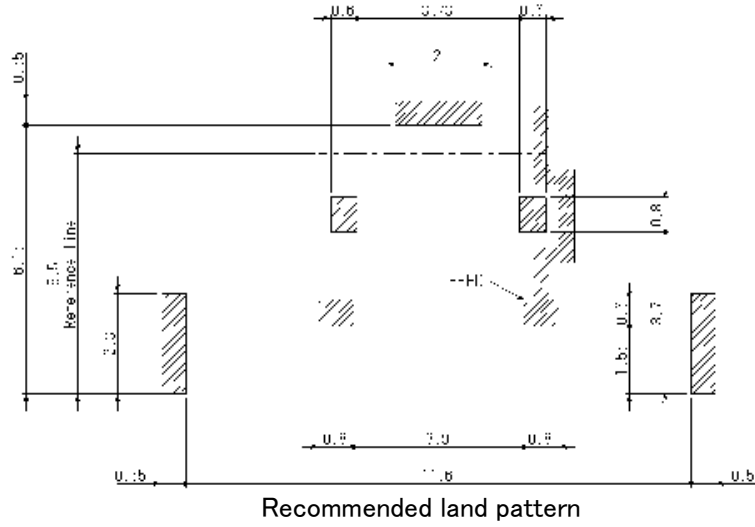

Recommended land pattern

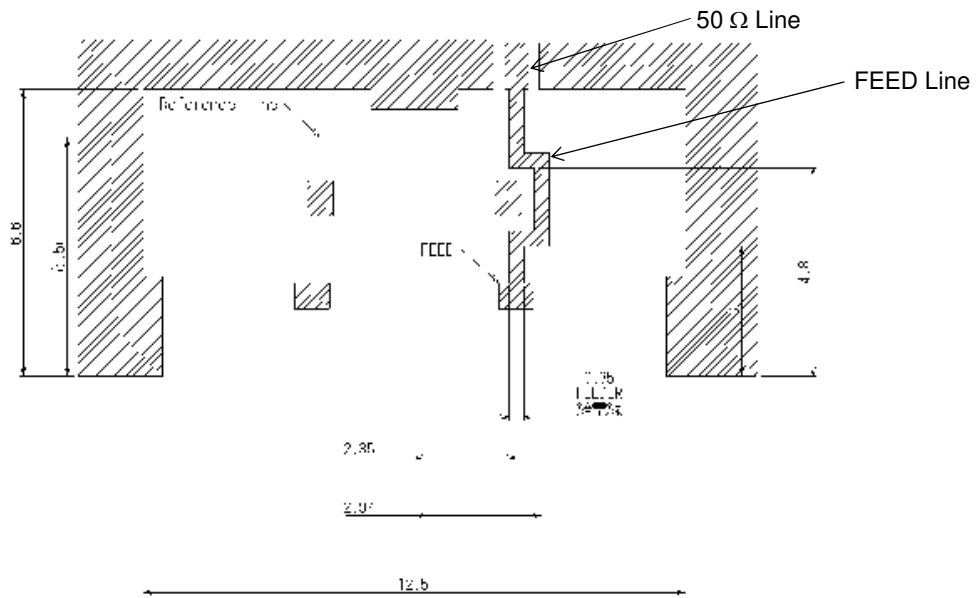

Reference board

7. 推奨リフロー温度プロファイル Recommended reflow temperature profile

	温度 Temperature	加熱時間 Heating time
予備加熱 Preheating temperature	180 to 200 °C	120s (max.)
本加熱 Main heating temperature	Above 220 °C	50s (max.)
ピーク温度 Peak temperature	250 °C (max.)	-

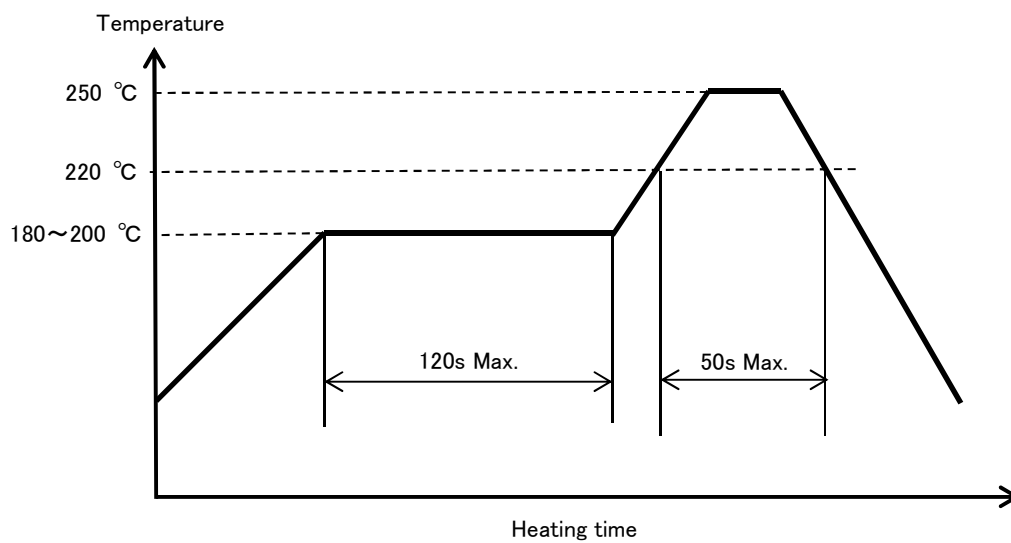



改版履歴 Revision history

文書番号 Document number	日付 Date	改版 Revision
GHT20-1210	01 Oct. 2020	初版 Initial version
GHT20-1589	03 Dec. 2020	2 版 Revision 2
GHT21-0732	04 Jun. 2021	3 版 Revision 3 <ul style="list-style-type: none"> - Sec. 3.6 材料を追加 Sec. 3.6: Added material - Sec. 4.5 ピークゲインの値を追加 Sec. 4.5: Added value of peak gain - 表記の修正 Editorial changes
GHT21-0732-1	07 Jul. 2021	4 版 Revision 4 <ul style="list-style-type: none"> - 表記の修正 Editorial changes
GHT21-0732-2	08 Oct. 2021	5 版 Revision 5 <ul style="list-style-type: none"> - 表記の修正 Editorial changes