

ELECTRICAL SPECIFICATIONS:

1.0 TURNS RATIO (P6-P8-P3) :	(J6-J3)	: 1CT : 1 ± 3%
(P2-P7-P1) :	(J2-J1)	: 1CT : 1.4 ± 3%
2.0 INDUCTANCE (P6-P3)=(J6-J3)		: 200uH MIN. @ 0.01V, 10KHZ
(P2-P1)		: 100uH MIN. @ 0.01V, 10KHZ
3.0 LEAKAGE INDUCTANCE P6-P3 (WITH J6 AND J3 SHORT)		: 0.3uH MAX. @ 1MHz
P2-P1 (WITH J2 AND J1 SHORT)		: 0.3uH MAX. @ 1MHz
4.0 INTERWINDING CAPACITANCE (P6,P3) TO (J6,J3)		: 20pf MAX @ 1MHz
(P2,P1) TO (J2,J1)		: 20pf MAX. @ 1MHz
5.0 DC RESISTANCE (J6-J3)=(J2-J1)		: 1.0 ohms Max.
(P6-P8)=(P8-P3)		: 0.5 ohms Max.
(P2-P7)=(P7-P1)		: 0.3 ohms Max.
6.0 DIELECTRIC WITHSTAND (P6,P3) TO (J6,J3)		: 1500VAC for 60 seconds
(P2,P1) TO (J2,J1)		: 1500VAC for 60 seconds

NOTES

1.0 PINS WITHOUT ELECTRICAL CONNECTIONS ARE OMITTED.

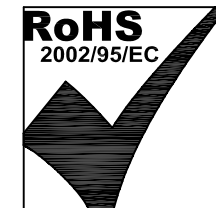

Bel Stewart Connector  
11118 Susquehanna Trail, South  
Glen Rock, Pa 17327-9199  
717.234.7512

**MagJack**

<http://www.stewartconnector.com>

THIS DRAWING AND THE SUBJECT MATTER SHOWN THEREON ARE CONFIDENTIAL AND PROPERTY OF BEL STEWART CONNECTOR AND SHALL NOT BE REPRODUCED, COPIED, OR USED IN ANY MANNER WITHOUT PRIOR WRITTEN CONTENT OF BEL STEWART CONNECTOR. THE SUBJECT MATTER MAY BE PATENTED OR A PATENT MAY BE PENDING.

SHEET  
1 OF 3

DRAWING NO.  
SI-60143-F

REV.  
09

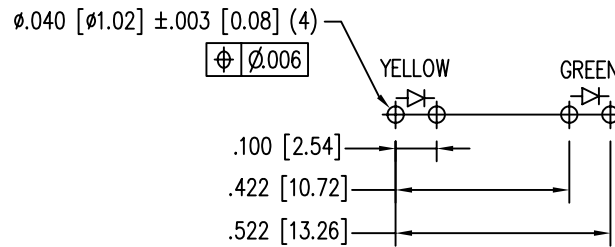

DETAIL "B"  
TYPICAL LED HOLE LAYOUT

LED POLARITY  
(ENLARGED VIEW)

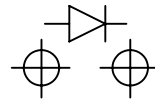

SINGLE COLOR LED

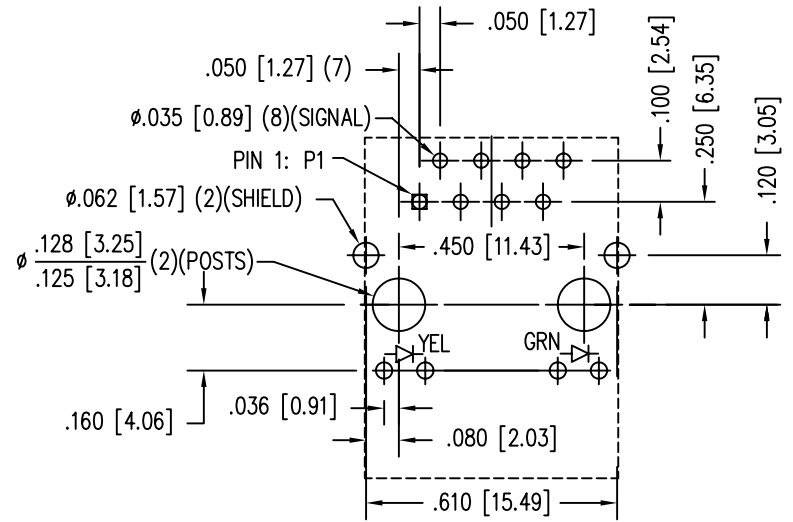
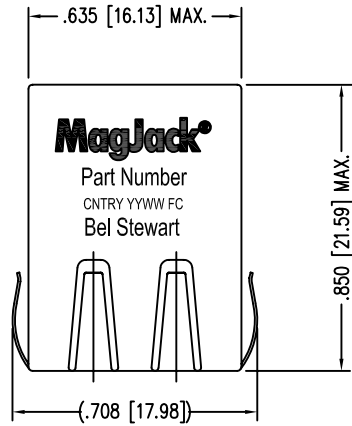

P.C.B. RECOMMENDED HOLE LAYOUT  
SEEN FROM COMPONENT SIDE

ALL CENTERLINE DIMENSIONS ARE BASIC.

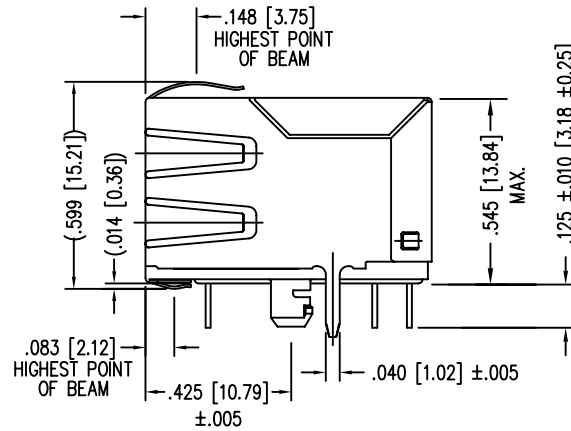
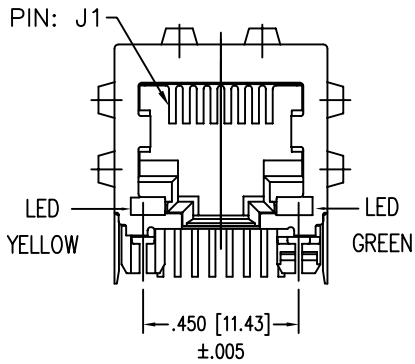

LED SPECIFICATION			
STANDARD LED	WAVELENGTH	Forward V (MAX)	*(TYP)
GREEN	565 nm	2.5 V	2.2 V
YELLOW	590 nm	2.5 V	2.1 V

\*WITH A FORWARD CURRENT OF 20 mA (TYP)

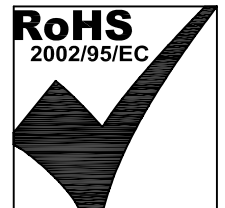

NOTES:

- CONNECTOR MATERIALS:  
HOUSING: THERMOPLASTIC UL94 V-0  
CONTACT/SHIELD: COPPER ALLOY  
SHIELD PLATING: NICKEL OR TIN  
CONTACT PLATING: SELECTIVE GOLD,  
50 MICRO-INCHES MIN. IN CONTACT AREA.
- PIN NOT ELECTRICALLY CONNECTED MAYBE OMITTED.  
SEE ELECTRICAL DRAWING FOR OMITTED PINS.
- TOLERANCES COMPLY WITH F.C.C. DIMENSION REQUIREMENTS.
- ALL TOLERANCES NOT OTHERWISE SPECIFIED TO BE ±0.005 [0.13]
- REFLOW AND WAVE SOLDER COMPATIBLE -260°C FOR 10 SECONDS MAX.

Bel Stewart Connector  
11118 Susquehanna Trail, South  
Glen Rock, Pa 17327-9199  
717.234.7512

**MagJack®**

<http://www.stewartconnector.com>

THIS DRAWING AND THE SUBJECT MATTER SHOWN THEREON ARE CONFIDENTIAL AND PROPERTY OF BEL STEWART CONNECTOR AND SHALL NOT BE REPRODUCED, COPIED, OR USED IN ANY MANNER WITHOUT PRIOR WRITTEN CONTENT OF BEL STEWART CONNECTOR. THE SUBJECT MATTER MAY BE PATENTED OR A PATENT MAY BE PENDING.

SHEET  
2 OF 3

DRAWING NO.  
SI-60143-F

REV.  
12

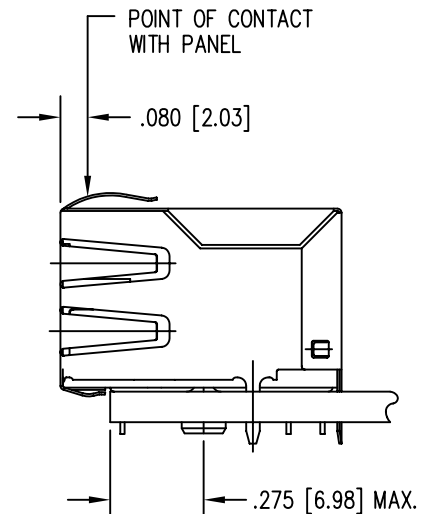
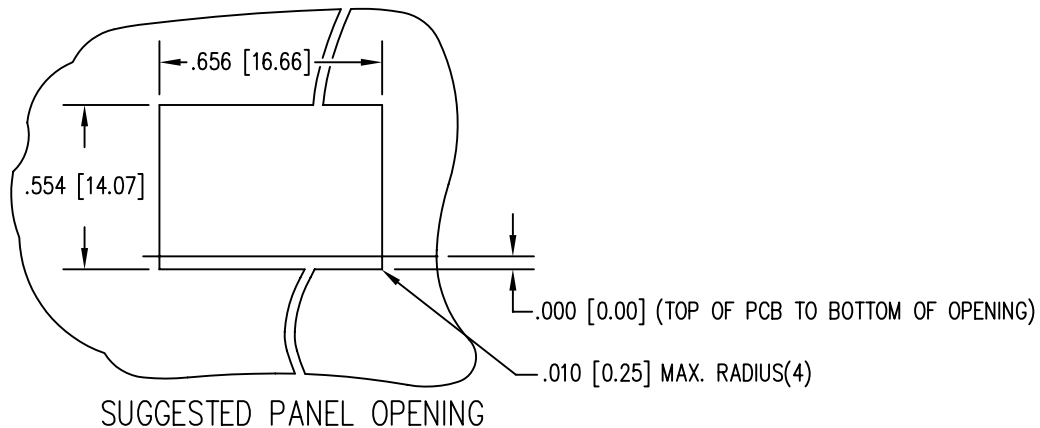

1. THE SUGGESTED PANEL OPENING IS INTENDED TO GIVE THE USER THE ABILITY TO HAVE REASONABLE JACK / PANEL CLEARANCES YET MAINTAIN RELIABLE GROUNDING CAPABILITY.
2. ALL TOLERANCES NOT OTHERWISE SPECIFIED TO BE  $\pm 0.005$  [0.13]

Bel Stewart Connector  
 11118 Susquehanna Trail, South  
 Glen Rock, Pa 17327-9199  
 717.234.7512

**MagJack®**

<http://www.stewartconnector.com>

THIS DRAWING AND THE SUBJECT MATTER SHOWN THEREON ARE CONFIDENTIAL AND PROPERTY OF BEL STEWART CONNECTOR AND SHALL NOT BE REPRODUCED, COPIED, OR USED IN ANY MANNER WITHOUT PRIOR WRITTEN CONTENT OF BEL STEWART CONNECTOR. THE SUBJECT MATTER MAY BE PATENTED OR A PATENT MAY BE PENDING.

SHEET  
3 OF 3

DRAWING NO.  
SI-60143-F

REV.  
12