

# CGHV1F006S

6 W, DC - 15 GHz, 40 V, GaN HEMT

## Description

WolfSpeed's CGHV1F006S is an unmatched, gallium nitride (GaN) high electron mobility transistor (HEMT) designed specifically for high efficiency, high gain and wide bandwidth capabilities. The device can be deployed for L, S, C, X and Ku-Band amplifier applications. The datasheet specifications are based on a C-Band (5.5 - 6.5 GHz) amplifier. Additional application circuits are available for C-Band at 5.8 GHz - 7.2 GHz and X-Band at 7.9 - 8.4 GHz and 8.5 - 9.6 GHz. The CGHV1F006S operates on a 40 volt rail circuit while housed in a 3mm x 4mm, surface mount, dual-flat-no-lead (DFN) package. Under reduced power, the transistor can operate below 40V to as low as 20V  $V_{DD}$ , maintaining high gain and efficiency.

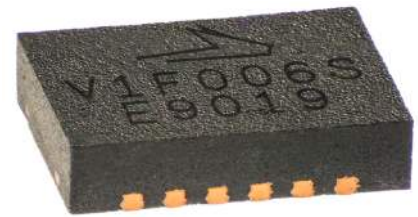

Package Type: 3x4 DFN  
PN: CGHV1F006S

### Features for 40 V in CGHV1F006S-AMP

- Up to 15 GHz Operation
- 8 W Typical Output Power
- 17 dB Gain at 6.0 GHz
- 15 dB Gain at 9.0 GHz
- Application circuits for 5.8 - 7.2 GHz, 7.9 - 8.4GHz, and 8.5 - 9.6 GHz.
- High degree of APD and DPD correction can be applied

### Typical Performance Over 5.5 - 6.5 GHz ( $T_c = 25^\circ\text{C}$ ), 40 V

Parameter	5.5 GHz	6.0 GHz	6.5 GHz	Units
Small Signal Gain	15.4	16.5	17.8	dB
Output Power @ $P_{IN} = 28$ dBm	38.6	39.3	39.0	dBm
Drain Efficiency @ $P_{IN} = 28$ dBm	55	57	52	%

### Listing of Available Hardware Application Circuits / Demonstration Circuits

Application Circuit	Operating Frequency	Amplifier Class	Operating Voltage
CGHV1F006S-AMP1	5.85 - 7.2 GHz	Class A/B	40 V
CGHV1F006S-AMP2	7.9 - 8.4 GHz	Class A/B	40 V
CGHV1F006S-AMP3	8.5 - 9.6 GHz	Class A/B	40 V
CGHV1F006S-AMP4	4.9 - 5.9 GHz	Class A/B	20 V



Large Signal Models Available for ADS and MWO





## Absolute Maximum Ratings (not simultaneous) at 25°C Case Temperature

Parameter	Symbol	Rating	Units	Notes
Drain-Source Voltage	$V_{DSS}$	120	V	25 °C
Gate-to-Source Voltage	$V_{GS}$	-10, +2		
Storage Temperature	$T_{STG}$	-65, +150	°C	
Operating Junction Temperature	$T_J$	225		
Maximum Forward Gate Current	$I_{GMAX}$	1.2	mA	25 °C
Maximum Drain Current <sup>1</sup>	$I_{DMAX}$	0.95	A	
Soldering Temperature <sup>2</sup>	$T_S$	245	°C	
Case Operating Temperature <sup>3,4</sup>	$T_C$	-40, +150		
Thermal Resistance, Junction to Case <sup>5</sup>	$R_{\theta JC}$	14.5	°C/W	85 °C

### Notes:

<sup>1</sup> Current limit for long term, reliable operation

<sup>2</sup> Refer to the Application Note on soldering at [wolfspeed.com/rf/document-library](http://wolfspeed.com/rf/document-library)

<sup>3</sup> Simulated at  $P_{DISS} = 2.4$  W

<sup>4</sup>  $T_C$  = Case temperature for the device. It refers to the temperature at the ground tab underneath the package. The PCB will add additional thermal resistance

<sup>5</sup> The  $R_{\theta TH}$  for Wolfspeed's application circuit, CGHV1F006S-AMP, with 31 (Ø11 mil) via holes designed on a 20 mil thick Rogers 5880 PCB, is 3.9°C/W. The total  $R_{\theta TH}$  from the heat sink to the junction is 14.5°C/W + 3.9°C/W = 18.4°C/W

## Electrical Characteristics (TC = 25°C), 40 V Typical

Characteristics	Symbol	Min.	Typ.	Max.	Units	Conditions
<b>DC Characteristics<sup>1</sup></b>						
Gate Threshold Voltage	$V_{GS(th)}$	-3.6	-3.0	-2.4	$V_{DC}$	$V_{DS} = 10$ V, $I_D = 1.2$ mA
Gate Quiescent Voltage	$V_{GS(Q)}$	-	-2.7	-	$V_{DC}$	$V_{DS} = 40$ V, $I_D = 60$ mA
Saturated Drain Current <sup>2</sup>	$I_{DS}$	0.86	1.2	-	A	$V_{DS} = 6.0$ V, $V_{GS} = 2.0$ V
Drain-Source Breakdown Voltage	$V_{(BR)DSS}$	100	-	-	$V_{DC}$	$V_{GS} = -8$ V, $I_D = 1.2$ mA
<b>RF Characteristics<sup>3</sup> (<math>T_C = 25^\circ\text{C}</math>, <math>F_0 = 5.925</math> GHz unless otherwise noted)</b>						
Small Signal Gain <sup>3,4</sup>	G	15.15	17.4	-	dB	$V_{DD} = 40$ V, $I_{DQ} = 60$ mA, $P_{IN} = 10$ dBm
Output Power <sup>3,4</sup>	$P_{OUT}$	37.5	38.7	-	dBm	$V_{DD} = 40$ V, $I_{DQ} = 60$ mA, $P_{IN} = 25.5$ dBm
Drain Efficiency <sup>3,4</sup>	$\eta$	35	52	-	%	
Output Mismatch Stress <sup>4</sup>	VSWR	-	10 : 1	-	$\Psi$	No damage at all phase angles, $V_{DD} = 40$ V, $I_{DQ} = 60$ mA, $P_{IN} = 25.5$ dBm
<b>Dynamic Characteristics</b>						
Input Capacitance <sup>5</sup>	$C_{GS}$	-	1.3	-	pF	$V_{DS} = 40$ V, $V_{GS} = -8$ V, $f = 1$ MHz
Output Capacitance <sup>5</sup>	$C_{DS}$	-	0.31	-		
Feedback Capacitance	$C_{GD}$	-	0.04	-		

### Notes:

<sup>1</sup> Measured on wafer prior to packaging

<sup>2</sup> Scaled from PCM data

<sup>3</sup> Measured in Wolfspeed's production test fixture. This fixture is designed for high volume testing at 5.925 GHz

<sup>4</sup> Unmodulated Pulsed Signal 100  $\mu$ s, 10% duty cycle

<sup>5</sup> Includes package



## Electrical Characteristics When Tested in CGHV1F006S-AMP1 at C-Band Under OQPSK

Characteristics	Symbol	Min.	Typ.	Max.	Units	Conditions
RF Characteristics <sup>1</sup> ( $T_c = 25^\circ\text{C}$ , $F_0 = 5.8 - 7.2$ GHz unless otherwise noted)						
Gain	G	-	17.5	-	dB	$V_{DD} = 40\text{ V}$ , $I_{DQ} = 60\text{ mA}$ , $P_{IN} = 0\text{ dBm}$
Output Power <sup>2</sup>	$P_{OUT}$	-	39	-	dBm	$V_{DD} = 40\text{ V}$ , $I_{DQ} = 60\text{ mA}$ , $P_{IN} = 27\text{ dBm}$
Drain Efficiency <sup>2</sup>	$\eta$	-	55	-	%	
OQPSK <sup>3</sup>	ACLR	-	-36	-	dBc	$V_{DD} = 40\text{ V}$ , $I_{DQ} = 60\text{ mA}$ , $P_{OUT} = 33\text{ dBm}$
Output Mismatch Stress <sup>2</sup>	VSWR	-	10:1	-	$\Psi$	No damage at all phase angles, $V_{DS} = 40\text{ V}$ , $I_{DQ} = 60\text{ mA}$

### Notes:

<sup>1</sup> Measured in CGH1F006S-AMP1 Application Circuit

<sup>2</sup> Pulsed 100  $\mu\text{s}$ , 10% duty cycle

<sup>3</sup> OQPSK modulated signal, 1.6 msp/s, PN23, Alpha Filter = 0.2 Offset = 1.6 MHz

## Typical Performance - CGHV1F006S-AMP1 at C-Band Under OQPSK

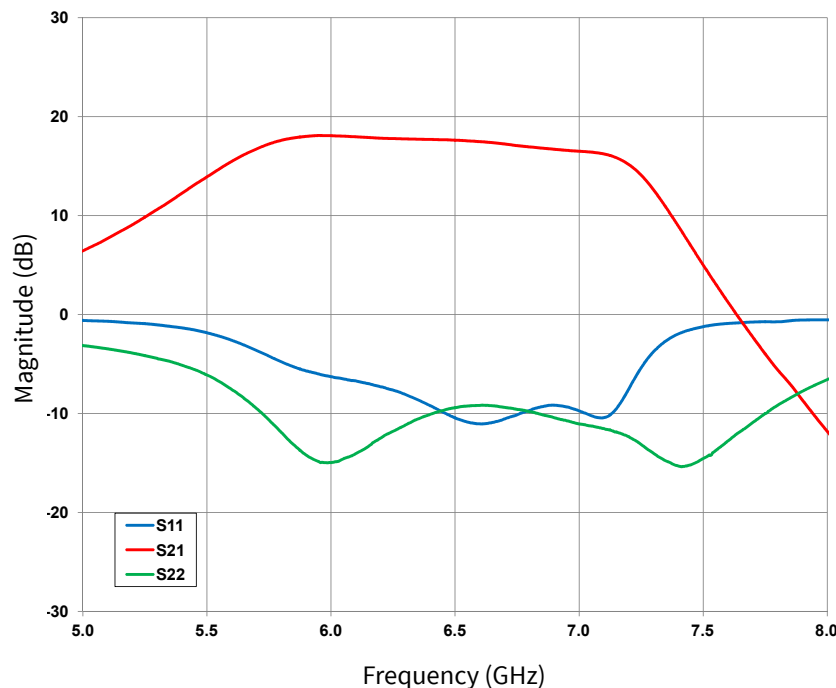

**Figure 1.** Typical Small Signal Response of CGHV1F006S-AMP1 Application Circuit  
 $V_{DD} = 40\text{ V}$ ,  $I_{DQ} = 60\text{ mA}$



**Typical Performance in Application Circuit CGHV1F006S-AMP1**

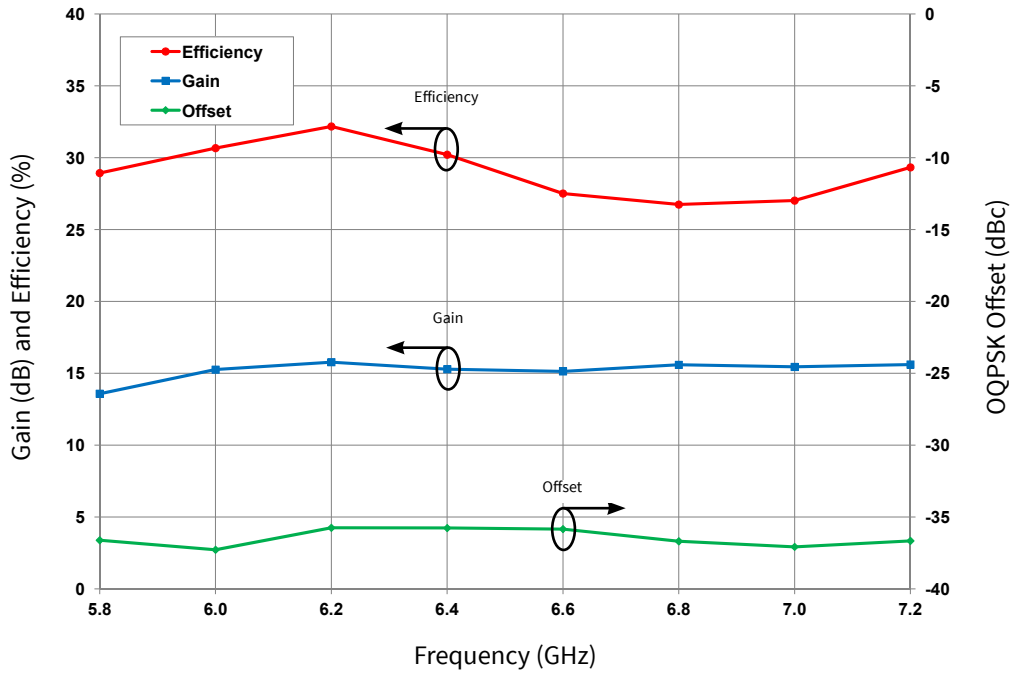

**Figure 2.** Typical Gain, Efficiency and OQPSK Performance vs Frequency  
 $P_{OUT} = 33 \text{ dBm}$ ,  $V_{DD} = 40 \text{ V}$ ,  $I_{DQ} = 60 \text{ mA}$

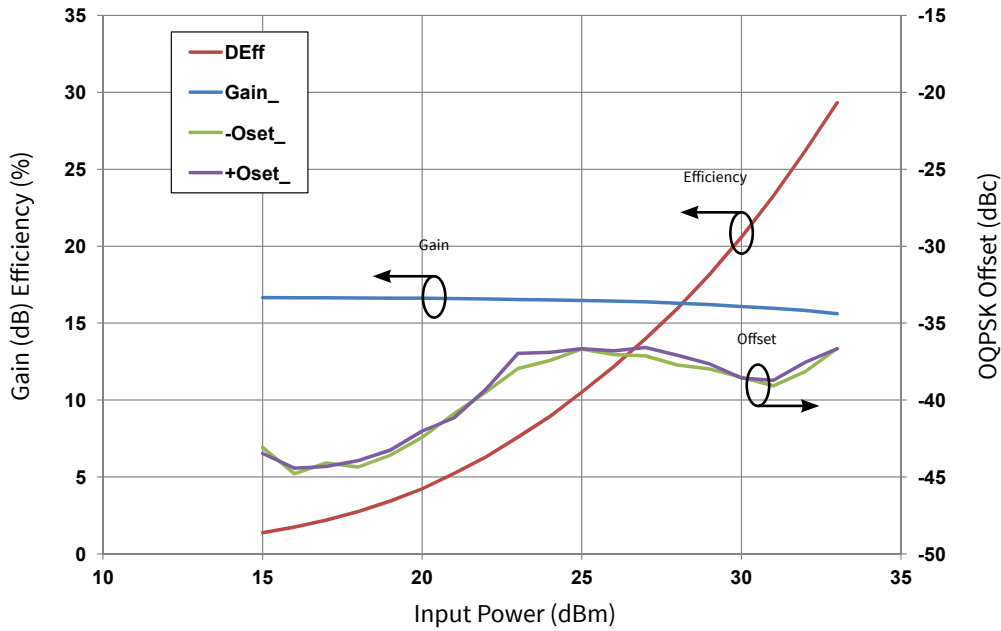

**Figure 3.** Typical Gain, Efficiency and OQPSK Performance vs Input Power OQPSK Transfer  
 Frequency = 7.2 GHz,  $V_{DD} = 40 \text{ V}$ ,  $I_{DQ} = 60 \text{ mA}$



## Typical Performance in Application Circuit CGHV1F006S-AMP1

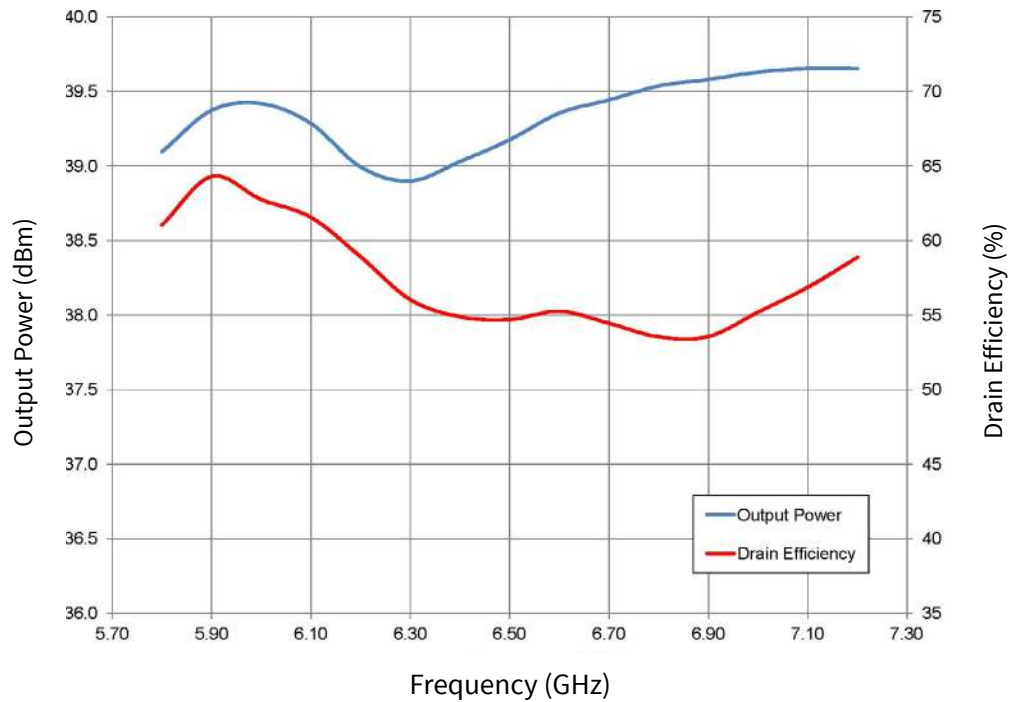
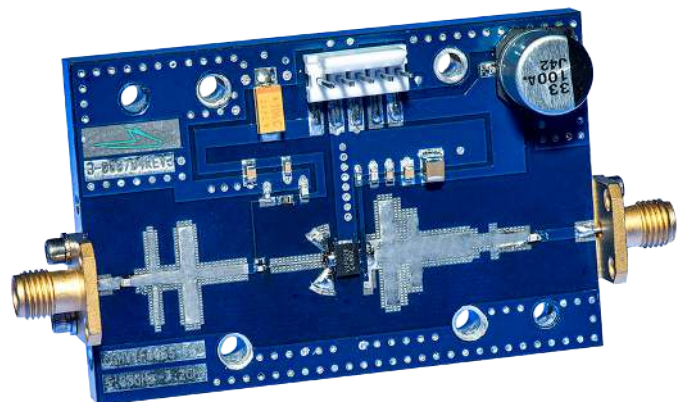

**Figure 4.** Typical Pulsed Power Response  
 $V_{DD} = 40\text{ V}$ ,  $I_{DQ} = 60\text{ mA}$ ,  $100\ \mu\text{s}$ , 10% Duty,  $P_{IN} = 27\text{ dBm}$

### CGHV1F006S-AMP1 Application Circuit Bill of Materials, OQPSK

Designator	Description	Qty
R1	RES, 15 ohm, +1/-1%, 1/16 W, 0402	1
R2	RES, 100 ohm, +1/-1%, 1/16 W, 0603	1
C1, C14	CAP, 1.8 pF, $\pm 0.1\text{ pF}$ , 0603, ATC	2
C2	CAP, 2.0 pF, $\pm 0.1\text{ pF}$ , 0402, ATC	1
C3, C8	CAP, 1.5 pF, $\pm 0.1\text{ pF}$ , 0402, ATC	2
C4	CAP, 10 pF, $\pm 5\%$ , 0603, ATC	1
C5, C10	CAP, 470 pF, 5%, 100 V, 0603, X	2
C6, C11	CAP, 33000 pF, 0805, 100V, X7R	2
C7	CAP, 10 $\mu\text{F}$ , 16 V, TANTALUM	1
C9	CAP, 20 pF, $\pm 5\%$ , 0603, ATC	1
C12	CAP, 1.0 $\mu\text{F}$ , 100V, 10% X7R, 1210	1
C13	CAP, 33 $\mu\text{F}$ , 20%, G CASE	1
J1, J2	CONN, SMA, PANEL MOUNT JACK, FLANGE	2
	PCB, RT5880, 0.020" THK, CGHV1F006S	1
J3	HEADER RT>PLZ .1CEN LK 5POS	1
Q1	QFN TRANSISTOR CGHV1F006S	1

### CGHV1F006S-AMP1 Application Circuit





**CGHV1F006S-AMP1 Application Circuit Schematic, OQPSK**

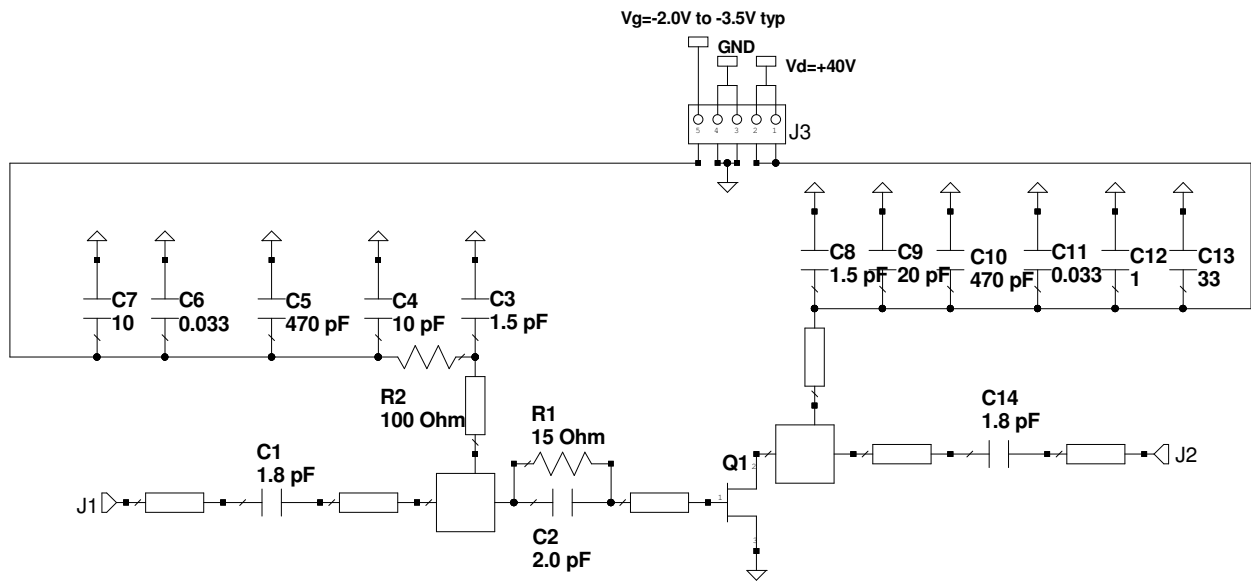

**CGHV1F006S-AMP1 Application Circuit Outline, OQPSK**

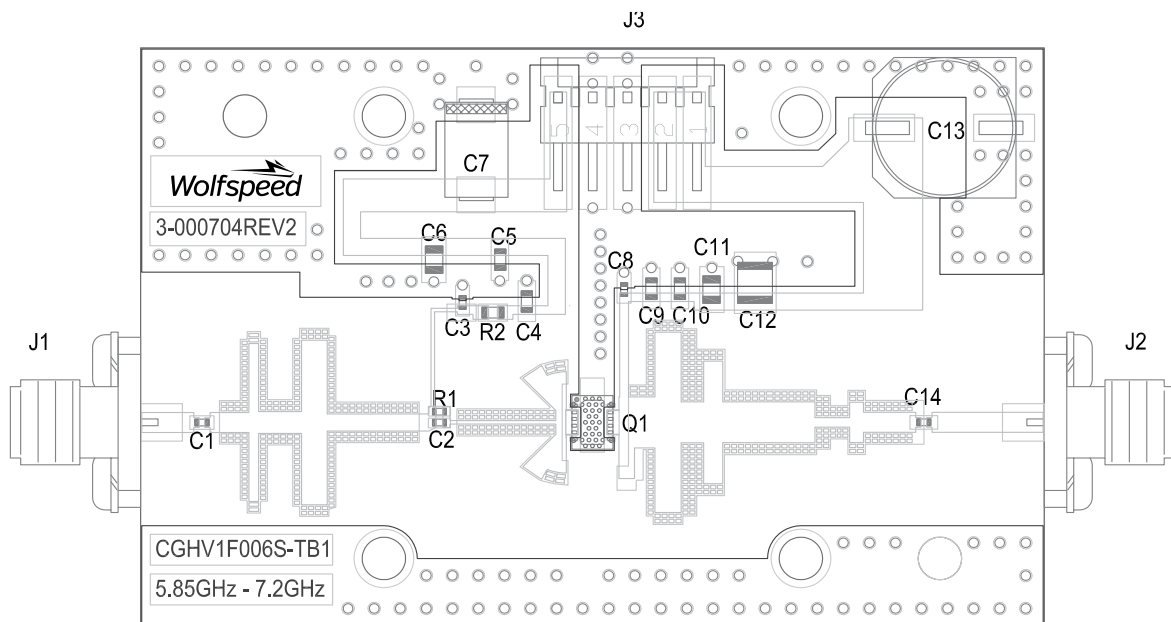



## Electrical Characteristics When Tested in CGHV1F006S-AMP2 at X-Band, SATCOM

Characteristics	Symbol	Min.	Typ.	Max.	Units	Conditions
RF Characteristics <sup>1</sup> ( $T_c = 25^\circ\text{C}$ , $F_0 = 7.9 - 8.4$ GHz unless otherwise noted)						
Gain	G	-	15	-	dB	$V_{DD} = 40\text{ V}$ , $I_{DQ} = 60\text{ mA}$ , $P_{IN} = 0\text{ dBm}$
Output Power <sup>2</sup>	$P_{OUT}$	-	39	-	dBm	$V_{DD} = 40\text{ V}$ , $I_{DQ} = 60\text{ mA}$ , $P_{IN} = 28\text{ dBm}$
Drain Efficiency <sup>2</sup>	$\eta$	-	55	-	%	
OQPSK <sup>3</sup>	ACLR	-	-37		dBc	$V_{DD} = 40\text{ V}$ , $I_{DQ} = 60\text{ mA}$ , $P_{OUT} = 33\text{ dBm}$
Output Mismatch Stress <sup>2</sup>	VSWR	-	10 : 1	-	$\Psi$	No damage at all phase angles, $V_{DD} = 40\text{ V}$ , $I_{DQ} = 60\text{ mA}$ , $P_{IN} = 28\text{ dBm}$

### Notes:

<sup>1</sup> Measured in CGHV1F006S-AMP2 Application Circuit

<sup>2</sup> Pulsed 100  $\mu\text{s}$ , 10% duty cycle

<sup>3</sup> OQPSK modulated signal, 1.6 msp/s, PN23, Alpha Filter = 0.2 Offset = 1.6 MHz

## Typical Performance in Application Circuit CGHV1F006S-AMP2 at X-Band, SATCOM

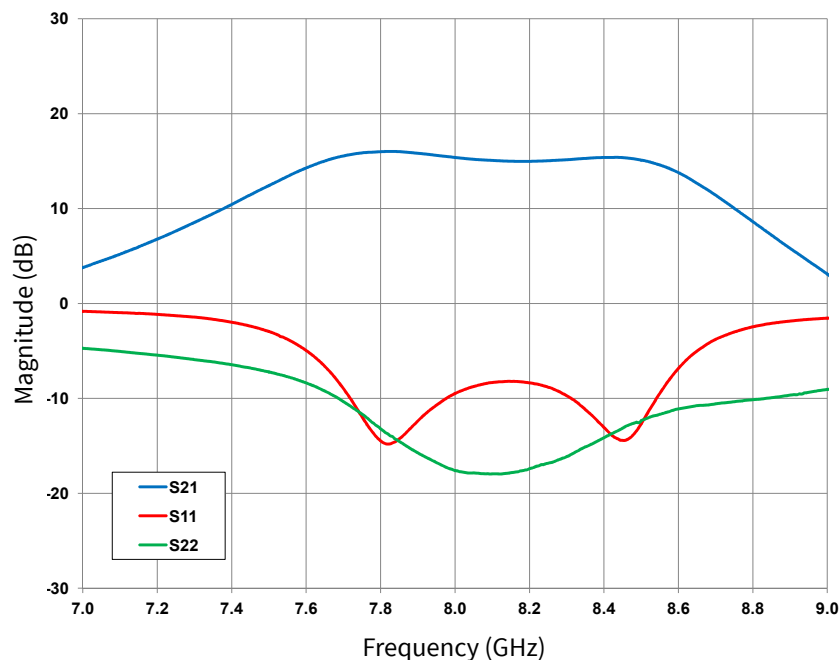

**Figure 5.** Typical Small Signal Response of CGHV1F006S-AMP2 Application Circuit  
 $V_{DD} = 40\text{ V}$ ,  $I_{DQ} = 60\text{ mA}$



**Typical Performance in Application Circuit CGHV1F006S-AMP2**

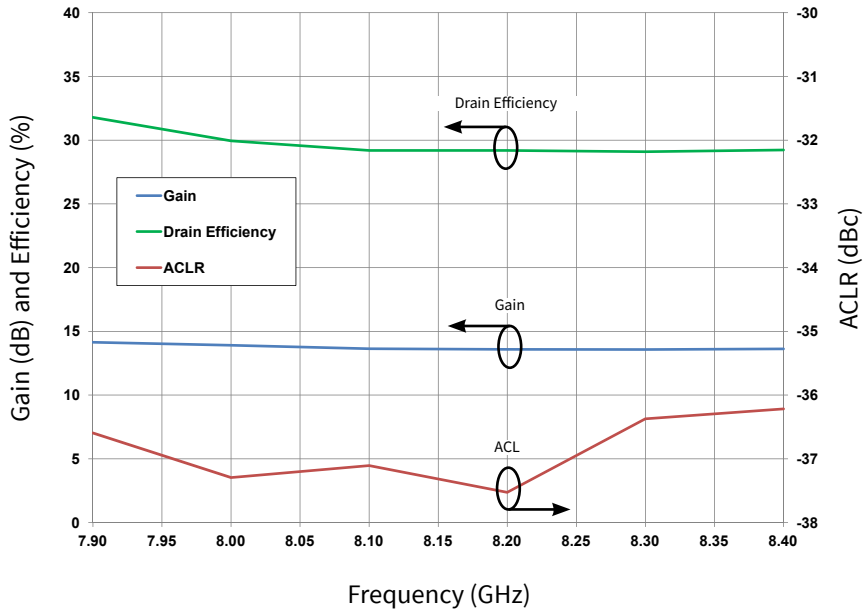

**Figure 6.** Typical OQPSK Response  
 $V_{DD} = 40\text{ V}$ ,  $I_{DQ} = 60\text{ mA}$ , 1.6 MSPS,  $P_{OUT} = 33\text{ dBm}$

**Typical Performance in Application Circuit CGHV1F006S-AMP2**

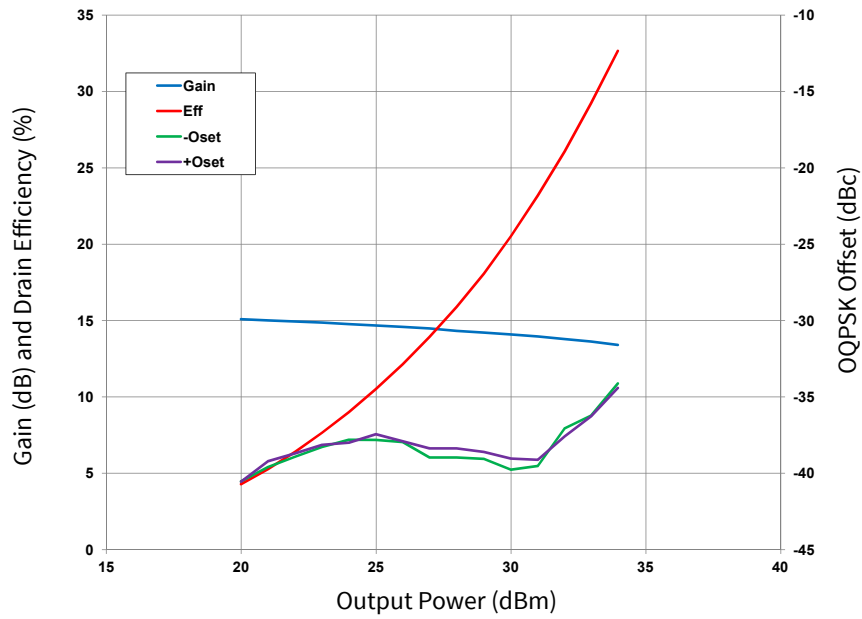

**Figure 7.** OQPSK Transfer Response  
 $V_{DD} = 40\text{ V}$ ,  $I_{DQ} = 60\text{ mA}$ , 1.6 MSPS, Frequency = 8.4 GHz



## Typical Performance in Application Circuit CGHV1F006S-AMP2

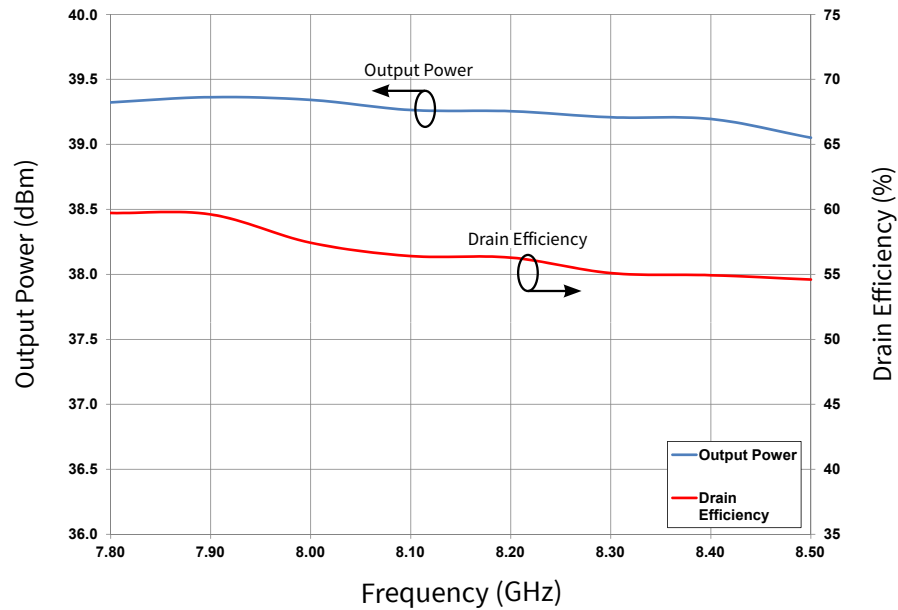
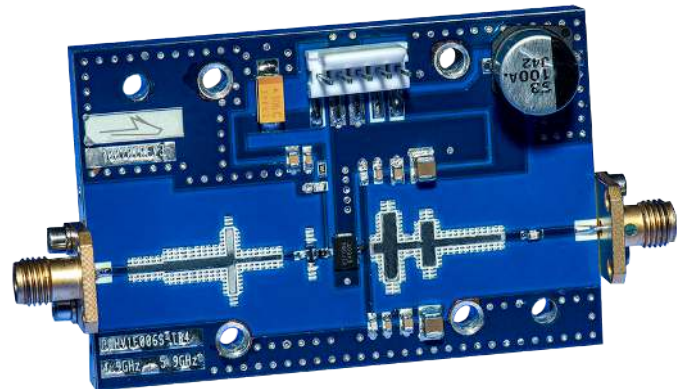

**Figure 8.** Typical Pulsed Power Response  
 $V_{DD} = 40\text{ V}$ ,  $I_{DQ} = 60\text{ mA}$ ,  $100\text{ }\mu\text{s}$ ,  $10\%$  Duty,  $P_{IN} = 28\text{ dBm}$

### CGHV1F006S-AMP2 Application Circuit Bill of Materials, SATCOM

Designator	Description	Qty
R1	RES, 15 ohm, +/-1%, 1/16 W, 0402	1
R2	RES, 100 ohm, +/-1%, 1/16 W, 0603	1
C3, C8	CAP, 1.0 pF, ±0.05 pF, 0402, ATC	2
C14	CAP, 1.0 pF, ±5%, 0603, ATC	1
C1	CAP, 1.2 pF, ±5%, 0603, ATC	1
C2	CAP, 1.6 pF, ±5%, 0402, ATC	1
C4	CAP, 10 pF, ±5%, 0603, ATC	1
C5, C10	CAP, 470 pF, 5%, 100V, 0603, X	2
C6, C11	CAP, 33000 pF, 0805, 100V, X7R	2
C7	CAP, 10 μF, 16 V, TANTALUM	1
C9	CAP, 20 pF, ±5%, 0603, ATC	1
C12	CAP, 1.0 μF, 100V, 10%, X7R, 1210	1
C13	CAP, 33 μF, 20%, G CASE	1
J1, J2	CONN, SMA, PANEL MOUNT JACK, FLANGE	2
	PCB, RT5880, 0.020" THK, CGHV1F006S	1
	BASEPLATE, AL, 2.60 X 1.70 X 2.50	1
J3	HEADER RT>PLZ .1CEN LK 5POS	1
	2-56 SOC HD SCREW 1/4 SS	4
	#2 SPLIT LOCKWASHER SS	4
Q1	QFN TRANSISTOR CGHV1F006S	1

### CGHV1F006S-AMP2 Application Circuit





**CGHV1F006S-AMP2 Application Circuit Schematic, SATCOM**

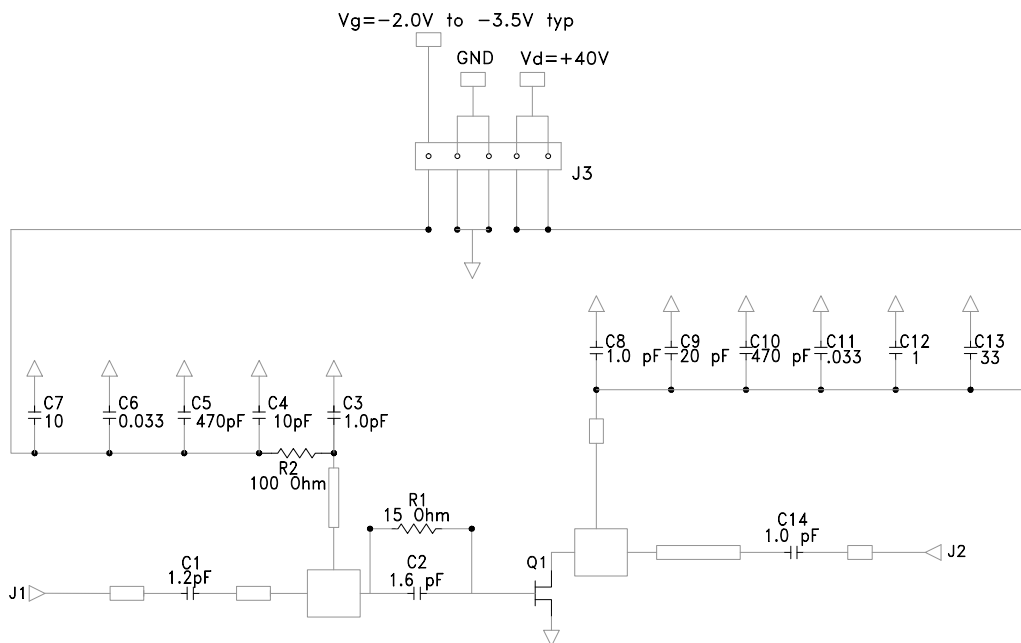

**CGHV1F006S-AMP2 Application Circuit Outline, SATCOM**

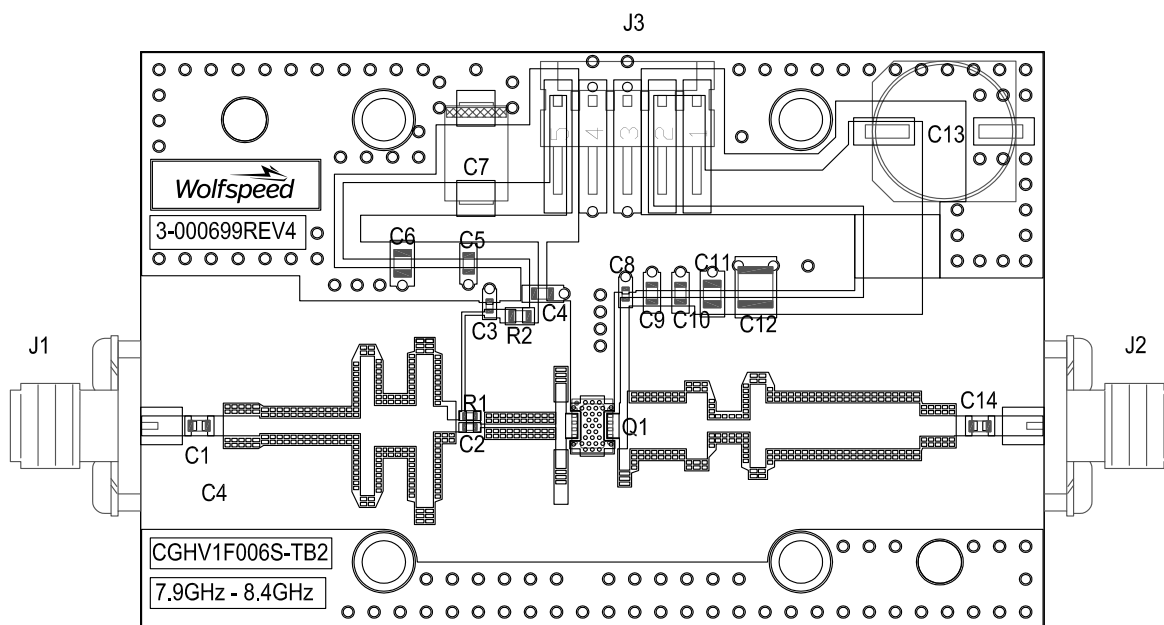



## Electrical Characteristics When Tested in CGHV1F006S-AMP3 at X-Band, RADAR

Characteristics	Symbol	Min.	Typ.	Max.	Units	Conditions
<b>RF Characteristics<sup>1</sup> (<math>T_c = 25^\circ\text{C}</math>, <math>F_0 = 8.5 - 9.6</math> GHz unless otherwise noted)</b>						
Gain	G	-	14.5	-	dB	$V_{DD} = 40$ V, $I_{DQ} = 60$ mA, $P_{IN} = 0$ dBm
Output Power <sup>2</sup>	$P_{OUT}$	-	38.5	-	dBm	$V_{DD} = 40$ V, $I_{DQ} = 60$ mA, $P_{IN} = 28$ dBm
Drain Efficiency <sup>2</sup>	$\eta$	-	52	-	%	
Output Mismatch Stress <sup>2</sup>	VSWR	-	10 : 1	-	$\Psi$	

### Notes:

<sup>1</sup> Measured in CGHV1F006S-AMP3 Application Circuit

<sup>2</sup> Pulsed 100  $\mu$ s, 10% duty cycle

## Typical Performance in Application Circuit CGHV1F006S-AMP3 at X-Band, RADAR

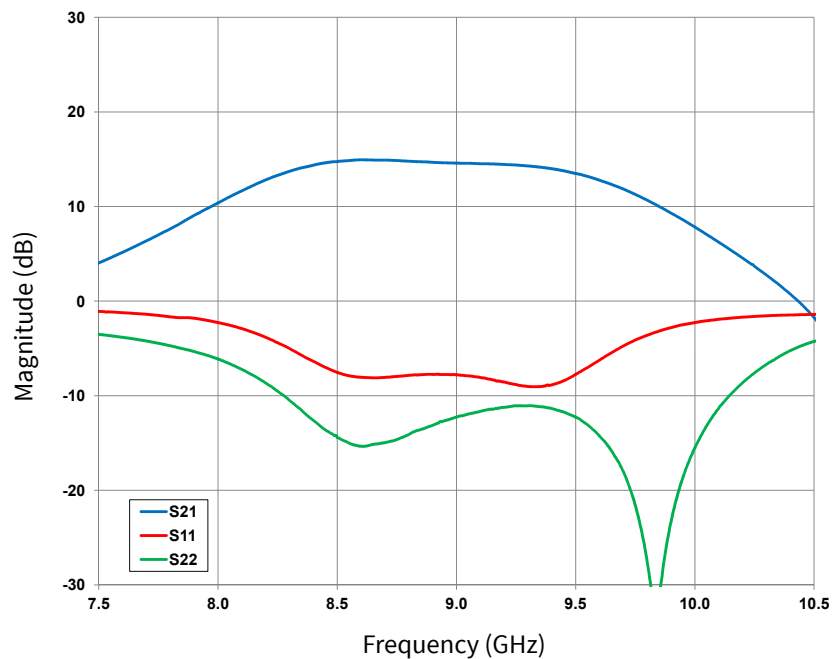

**Figure 9.** Typical Small Signal Response

$V_{DD} = 40$  V,  $I_{DQ} = 60$  mA

## Typical Performance in Application Circuit CGHV1F006S-AMP3

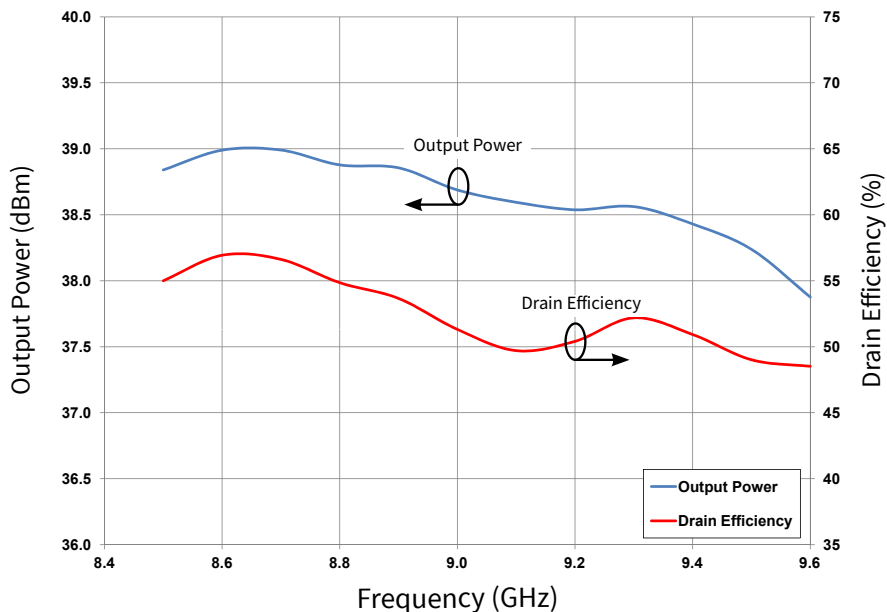
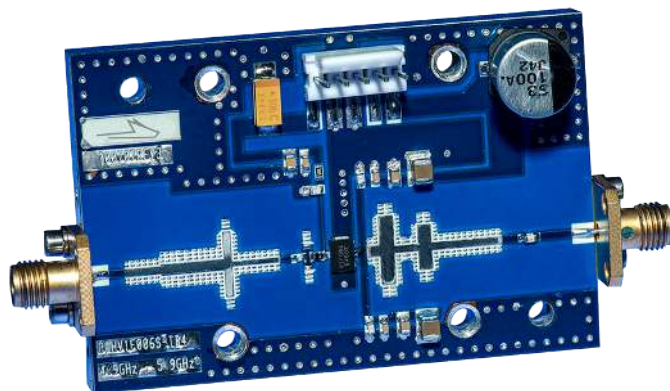

**Figure 10.** Typical Pulsed Power Response  
 $V_{DD} = 40\text{ V}$ ,  $I_{DQ} = 60\text{ mA}$ ,  $100\ \mu\text{s}$ , 10% Duty,  $P_{IN} = 28\text{ dBm}$

### CGHV1F006S-AMP3 Application Circuit Bill of Materials, RADAR

Designator	Description	Qty
R1	RES, 15 ohm, +/-1%, 1/16 W, 0402	1
R2	RES, 100 ohm, +/-1%, 1/16 W, 0603	1
C1, C14	CAP, 1.0 pF, ±0.05 pF, 0603, ATC	2
C2	CAP, 1.0 pF, ±0.05 pF, 0402, ATC	1
C3, C8	CAP, 0.8 pF, ±0.05 pF, 0402, ATC	2
C4	CAP, 10 pF, ±5%, 0603, ATC	1
C5, C10	CAP, 470 pF, 5%, 100 V, 0603, X	2
C6, C11	CAP, 33000 pF, 0805, 100V, X7R	2
C7	CAP, 10 μF, 16 V, TANTALUM	1
C9	CAP, 20 pF, ±5%, 0603, ATC	1
C12	CAP, 1.0 μF, 100V, 10% X7R, 1210	1
C13	CAP, 33 μF, 20%, G CASE	1
J1, J2	CONN, SMA, PANEL MOUNT JACK, FLANGE	2
J3	HEADER RT>PLZ .1CEN LK 5POS	1
Q1	QFN TRANSISTOR CGHV1F006S	1

### CGHV1F006S-AMP3 Application Circuit





### CGHV1F006S-AMP3 Application Circuit Schematic, RADAR

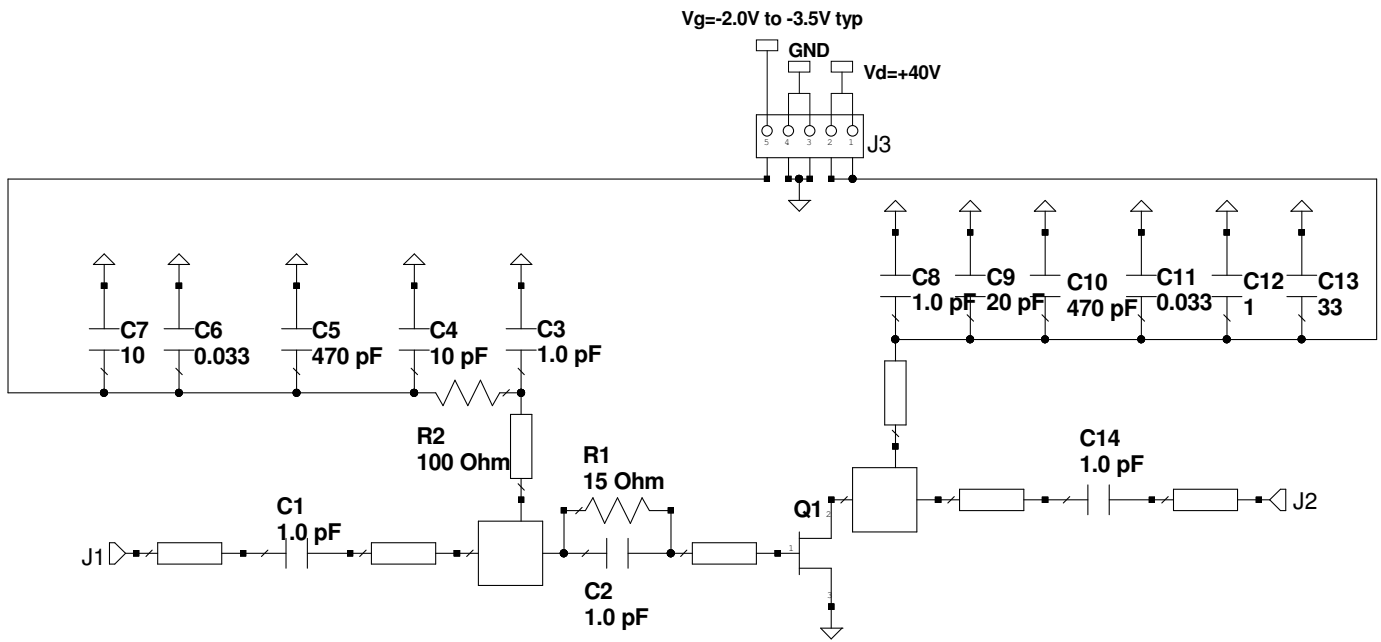

### CGHV1F006S-AMP3 Application Circuit Outline, RADAR

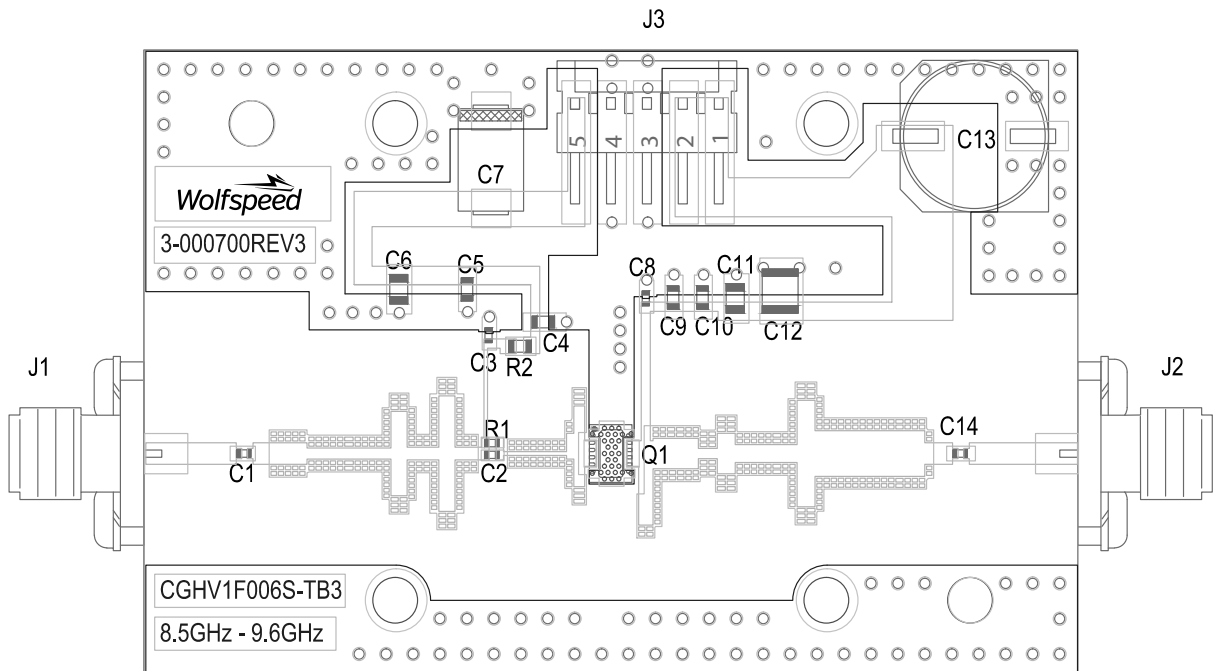



**Electrical Characteristics When Tested in CGHV1F006S-AMP4 at 802.11**

Characteristics	Symbol	Min.	Typ.	Max.	Units	Conditions
<b>RF Characteristics<sup>1</sup> (<math>T_c = 25^\circ\text{C}</math>, <math>F_0 = 4.9 - 5.9\text{ GHz}</math> unless otherwise noted)</b>						
Gain	G	-	13	-	dB	$V_{DD} = 20\text{ V}$ , $I_{DQ} = 30\text{ mA}$ , $P_{IN} = 27\text{ dBm}$
Drain Efficiency <sup>2</sup>	$\eta$	-	27	-	%	
OQPSK <sup>3</sup>	ACLR	-	-43	-	dBc	$V_{DD} = 20\text{ V}$ , $I_{DQ} = 30\text{ mA}$ , $P_{OUT} = 27\text{ dBm}$
Output Mismatch Stress <sup>2</sup>	VSWR	-	10 : 1	-	$\Psi$	No damage at all phase angles, $V_{DD} = 20\text{ V}$ , $I_{DQ} = 30\text{ mA}$ , $P_{IN} = 27\text{ dBm}$

Notes:

<sup>1</sup> Measured in CGHV1F006S-AMP4 Application Circuit

<sup>2</sup> Single carrier WCDMA, 3GPP Test Model 1, G4 DPCH, 45% clipping, PAR = 7.5 dB @ 0.01% probability on CCDF

**Typical Performance - CGHV1F006S-AMP4 at 802.11**

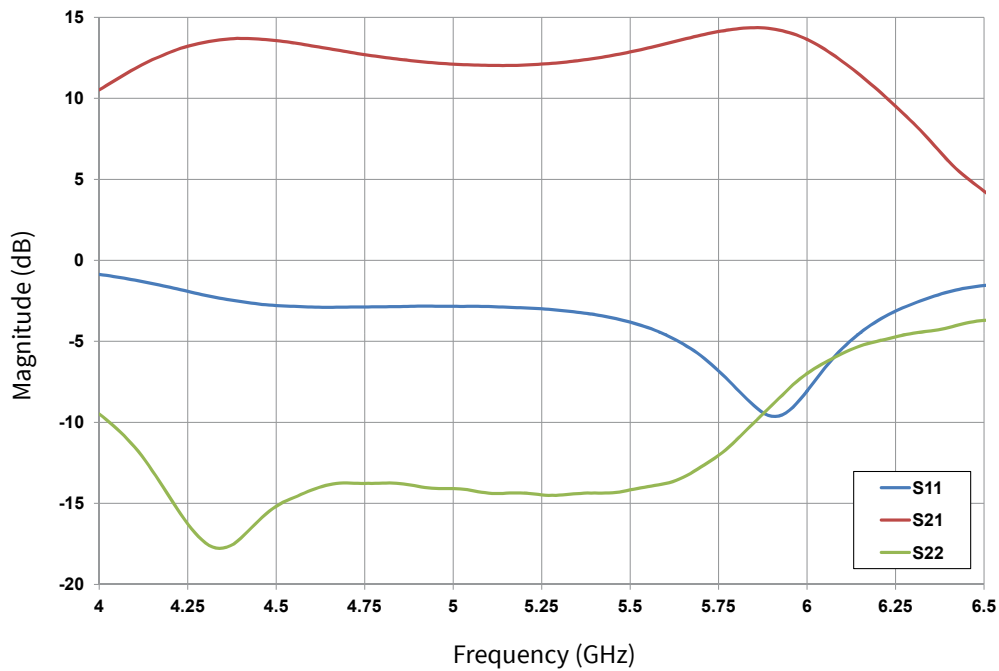

**Figure 11.** Typical Small Signal Response  
 $V_{DD} = 20\text{ V}$ ,  $I_{DQ} = 30\text{ mA}$



**Typical Performance in Application Circuit CGHV1F006S-AMP4**

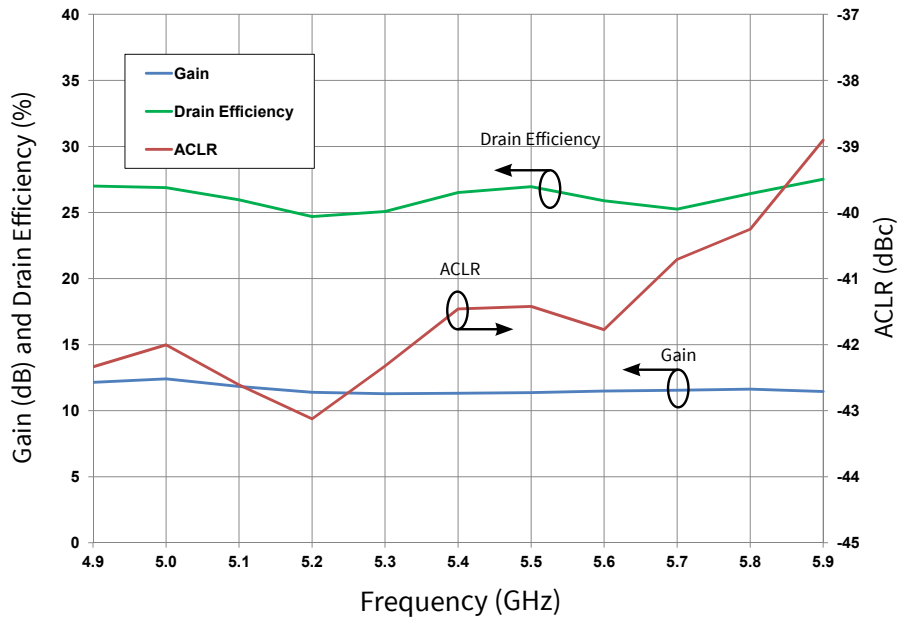
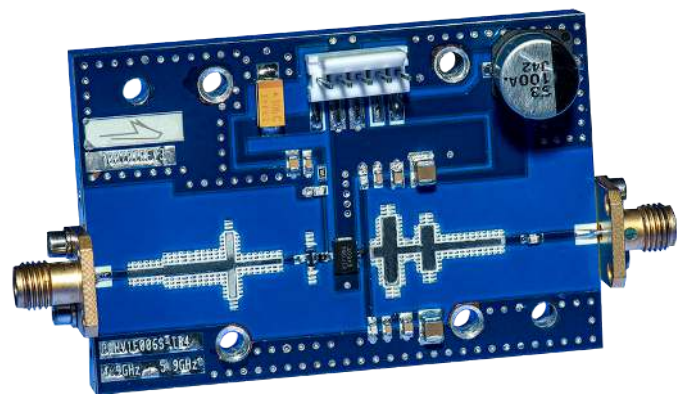

**Figure 12.** Typical Gain, Efficiency and WCDMA Performance vs Frequency  
 $V_{DD} = 20\text{ V}$ ,  $I_{DQ} = 30\text{ mA}$ ,  $P_{OUT} = 27\text{ dBm}$

**CGHV1F006S-AMP4 Application Circuit  
 Bill of Materials at 802.11**

Designator	Description	Qty
R1, R3	RES, 1 ohm, +/-1%, 1/16 W, 0402	2
R2	RES, 51.1, ohm, +/-1%, 1/16W, 0603	1
C2, C6, C11	CAP, 1.8 pF, +/-0.1 pF, 0603, ATC	3
C1	CAP, 0.2 pF, +/-0.05 pF, 0402, ATC	1
C3, C7, C12	CAP, 470 pF, 5%, 100 V, 0603, X	3
C4, C8, C13	CAP, 33000 pF, 0805, 100 V, X7R	3
C5	CAP, 10 μF, 16 V, TANTALUM	1
C15	CAP, 6.8 pF, ±0.25 pF, 100 V, 0603	1
C9, C14	CAP, 1.0 μF, 100V, 10% X7R, 1210	2
C10	CAP, 33 μF, 20%, G CASE	1
J1, J2	CONN, SMA, PANEL MOUNT JACK, FLANGE	2
	PCB, RO4350B, 0.020" THK, CGHV1F006S	1
	BASEPLATE, CGH35015, 2.60 X 1.7	1
J3	HEADER RT>PLZ .1CEN LK 5POS	1
	2-56 SOC HD SCREW 1/4 SS	4
	#2 SPLIT LOCKWASHER SS	4
Q1	QFN TRANSISTOR CGHV1F006S	1

**CGHV1F006S-AMP4 Application Circuit**





**CGHV1F006S-AMP4 Application Circuit Schematic, SATCOM**

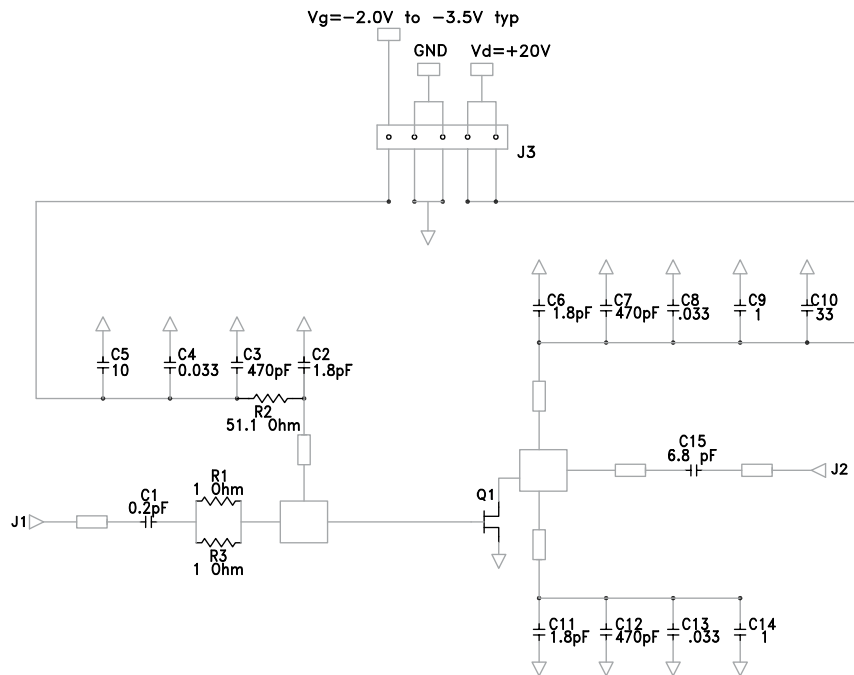

**CGHV1F006S-AMP4 Application Circuit Outline, SATCOM**

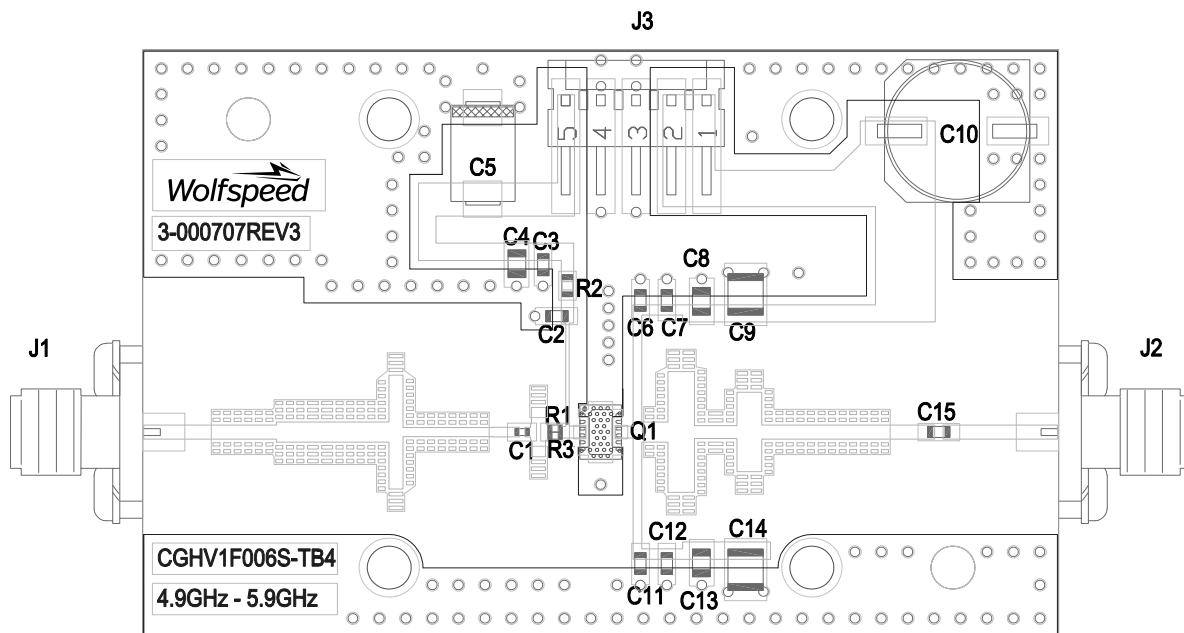





## CGHV1F006S Power Dissipation De-rating Curve

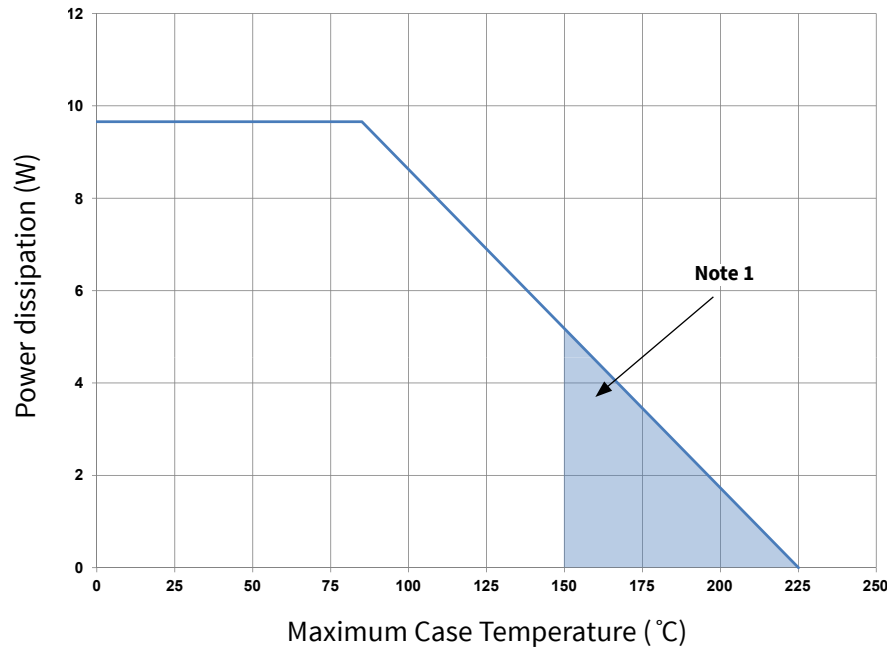

**Figure 13.** CGHV1F006S Transient Power Dissipation De-Rating Curve

Note:

<sup>1</sup> Area exceeds Maximum Case Temperature (See Page 2)

## Electrostatic Discharge (ESD) Classifications

Parameter	Symbol	Class	Classification Level	Test Methodology
Human Body Model	HBM	1B	ANSI/ESDA/JEDEC JS-001 Table 3	JEDEC JESD22 A114-D
Charge Device Model	CDM	0CB	ANSI/ESDA/JEDEC JS-002 Table 3	JEDEC JESD22 C101-C

## Moisture Sensitivity Level (MSL) Classification

Parameter	Symbol	Level	Test Methodology
Moisture Sensitivity Level	MSL	3 (168 hours)	IPC/JEDEC J-STD-20



## Source and Load Impedances

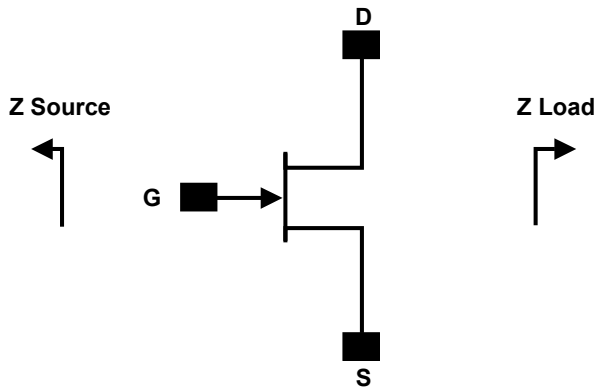

Frequency (GHz)	Z Source	Z Load
1	49.67 + j32.81	184.11 + j6.66
3	11.54 + j3.96	38.83 + j56.37
6	5.94 - j17.97	13.03 + j16.16
10	11.87 - j77.62	11.79 - j17.43
12	47.42 - j205.35	16.39 - j46.22
15	33.78 + j251.03	163.61 - j268.44

### Notes:

<sup>1</sup>  $V_{DD} = 40\text{ V}$ ,  $I_{DQ} = 60\text{ mA}$

<sup>2</sup> Impedances are extracted from source and load pull data derived from the transistor



**Product Dimensions CGHV1F006S (Package 3 x 4 DFN)**

SYMBOL	COMMON DIMENSIONS			NOTE
	MIN.	NOM.	MAX.	
A	0.80	0.90	1.0	
A1	0.00	0.02	0.05	
A3	0.203 REF.			
⌀	0		12	2
D	4.00 BSC			
E	3.00 BSC			
Ⓢ	0.50 BSC			
N	12			3
ND	6			⚠
L	0.35	0.40	0.45	
b	0.18	0.25	0.30	⚠
D2	3.20	3.30	3.40	
E2	1.60	1.7	1.80	
K	0.20			

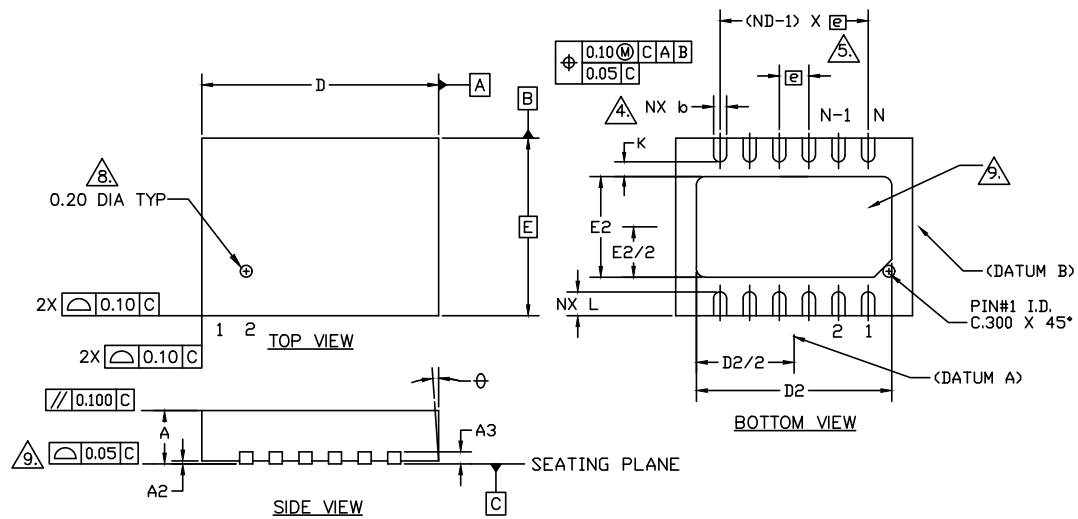

Pin	Input/Output
1	GND
2	NC
3	RF IN
4	RF IN
5	NC
6	GND
7	GND
8	NC
9	RF OUT
10	RF OUT
11	NC
12	GND

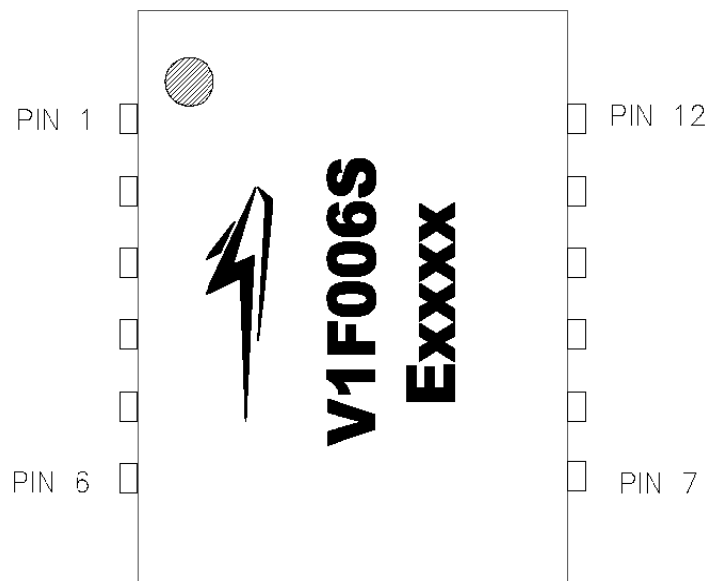



**Part Number System**

**CGHV1F006S**

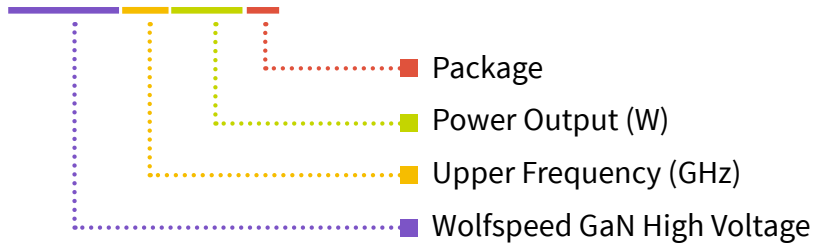

**Table 1.**

Parameter	Value	Units
Upper Frequency <sup>1</sup>	15.0	GHz
Power Output	6	W
Package	Surface Mount	-

Note:  
<sup>1</sup> Alpha characters used in frequency code indicate a value greater than 9.9 GHz. See Table 2 for value.

**Table 2.**

Character Code	Code Value
A	0
B	1
C	2
D	3
E	4
F	5
G	6
H	7
J	8
K	9
Examples:	1A = 10.0 GHz 2H = 27.0 GHz

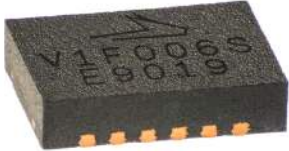
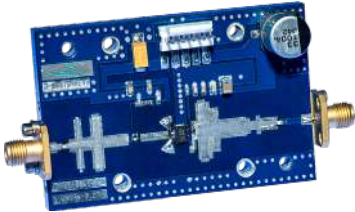
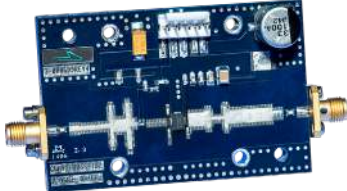
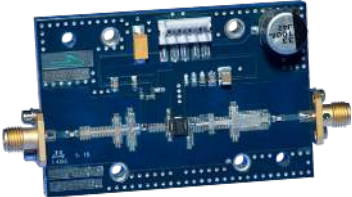
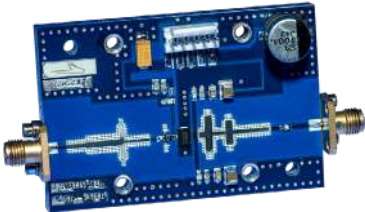

## Product Ordering Information

Order Number	Description	Unit of Measure	Image
CGHV1F006S	GaN HEMT	Each	
CGHV1F006S-AMP1	Test board with GaN HEMT installed, 5.85 - 7.2 GHz, 50 V C-Band under OQPSK	Each	
CGHV1F006S-AMP2	Test board with GaN HEMT installed, 7.9 - 8.4 GHz, 28 V X-Band SATCOM	Each	
CGHV1F006S-AMP3	Test board with GaN HEMT installed, 8.5 - 9.6 GHz, 28 V X-Band RADAR	Each	
CGHV1F006S-AMP4	Test board with GaN HEMT installed, 4.9 - 5.9 GHz, 50 V 802.11	Each	

**For more information, please contact:**

4600 Silicon Drive  
Durham, NC 27703 USA  
Tel: +1.919.313.5300  
[www.wolfspeed.com/RF](http://www.wolfspeed.com/RF)

Sales Contact  
[RFSales@wolfspeed.com](mailto:RFSales@wolfspeed.com)

RF Product Marketing Contact  
[RFMarketing@wolfspeed.com](mailto:RFMarketing@wolfspeed.com)

## Notes & Disclaimer

---

Specifications are subject to change without notice. “Typical” parameters are the average values expected by Wolfspeed in large quantities and are provided for information purposes only. Wolfspeed products are not warranted or authorized for use as critical components in medical, life-saving, or life-sustaining applications, or other applications where a failure would reasonably be expected to cause severe personal injury or death. No responsibility is assumed by Wolfspeed for any infringement of patents or other rights of third parties which may result from use of the information contained herein. No license is granted by implication or otherwise under any patent or patent rights of Wolfspeed.

© 2013-2022 Wolfspeed, Inc. All rights reserved. Wolfspeed® and the Wolfstreak logo are registered trademarks and the Wolfspeed logo is a trademark of Wolfspeed, Inc.  
PATENT: <https://www.wolfspeed.com/legal/patents>

*The information in this document is subject to change without notice.*