

xxxxxx

Wiring Diagram

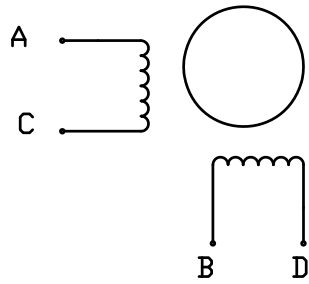

SPECIFICATIONS

1	Number of Phase	2
2	Step Angle	1.8° ±5%
3	Holding Torque	140 OZ-IN
4	Voltage	2.32 VDC
5	Current	2.8 A
6	Phase Resistance (20°C)	0.83 ± 10% Ω
7	Phase Inductance (1KHz)	2.2 ± 20% mH
8	Rotor Inertia	230g · cm ²
9	Insulation Resistance	100MΩ 500VDC
10	Insulation Class	B (130°C)
11	Ambient Temperature	-20°C to 50°C
12	Ambient Humidity	15% to 95%
13	Motor Weight	Approx 0.65kg
14		

DL20GT2-12-635-AF

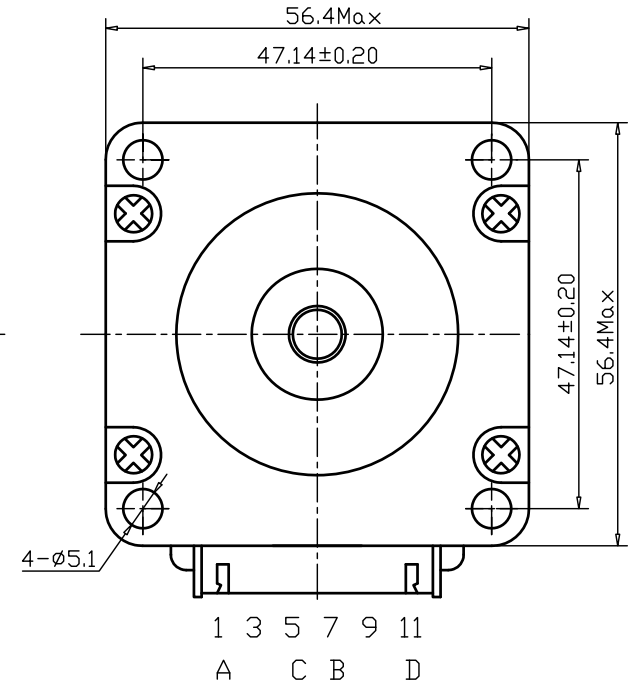
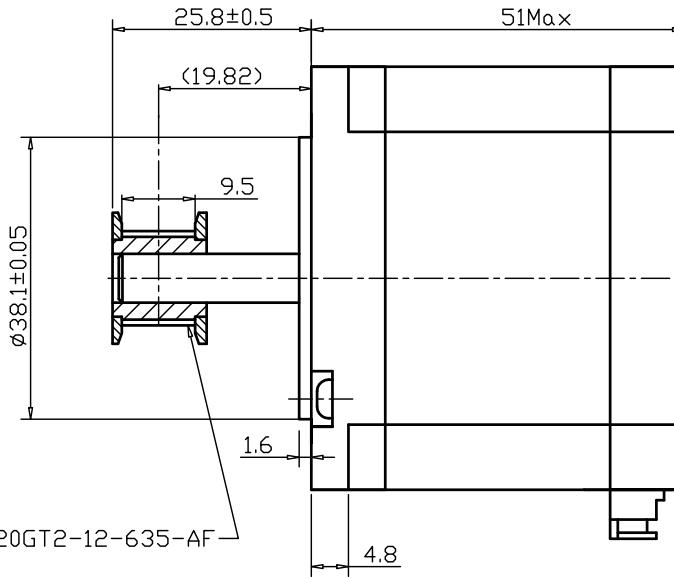

Unit:mm
 第一角画法
 First angle method
 未注线性与角度尺寸公差
 Tolerances for linear and angular dimensions
 without individual tolerance indications
 GB/T 1804-m eqv ISO 2768-1:m
 未注形状与位置尺寸公差
 Geometrical tolerances for features without
 individual tolerance indications
 GB/T 1184-k eqv ISO 2768-2:k

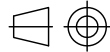

			DESIGN		20151111
			CHECK		
			TECHNOLOGY		
			STANDARD		
			APPROVE		
VI.0	20151111		NAMES	SINGATURE	DATE
REV.	DATE	UNLESS OTHERWISE SPECIFIDE			

STEPPING MOTOR

TYPE: HYBRID STEPPING MOTOR SCALE XX Rev. 1.0 SHEET 1 OF 1

Model: KL23H251-28-4Ap