

PRODUCT NUMBER  
SEE TABLE

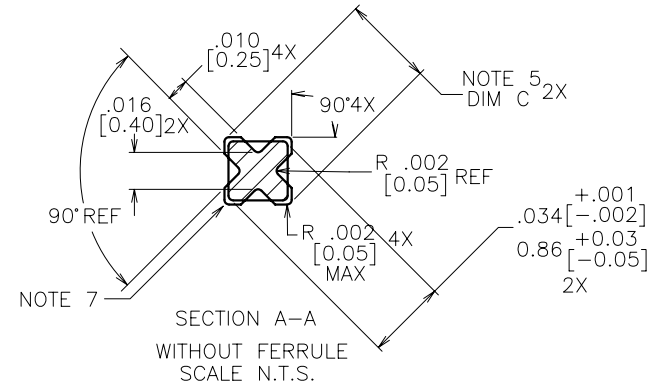
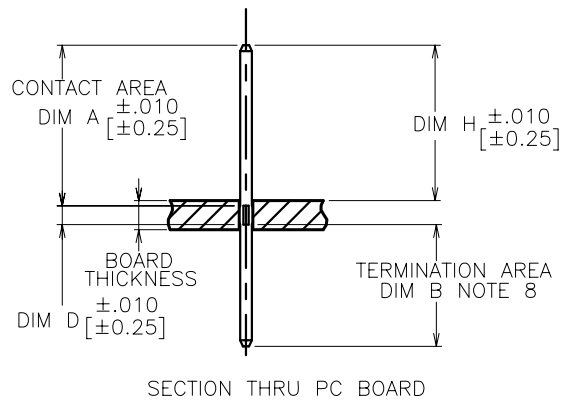
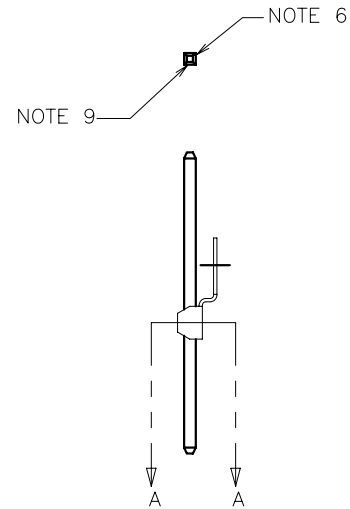
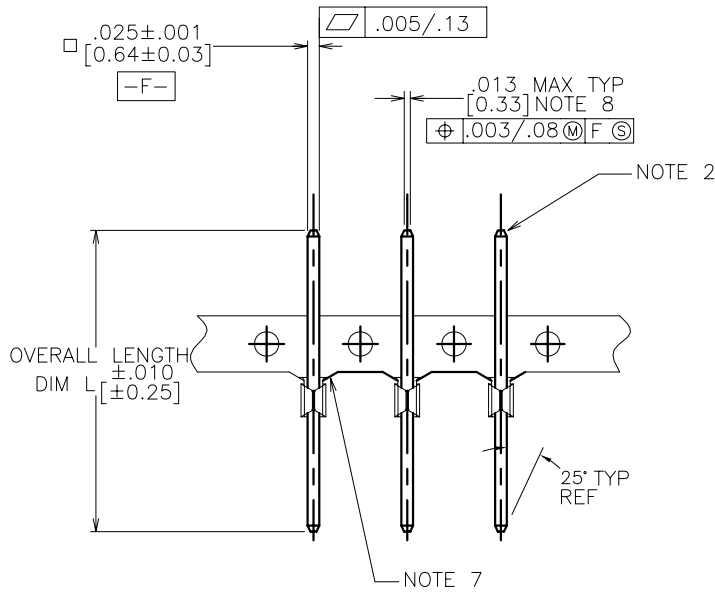

mat'l. code		surface		tolerance		projection		product family	
SEE NOTE 1		ASME Y14.5		ASME Y14.5		INCH/MM		PIN PRODUCTS	
ltr	ec'n no	dr	date	tolerances unless otherwise specified				title	
K	V08-0353	HTB	2008-08-19	angles	XX+01/XX+3	INCH/MM		BERGPIN® .200" [5.08] cc	
-	-	-	-	flat	XXX+005/XXX+13	scale 3:1		SHORT OVERALL LENGTH	
E	V01595	JRW	2000-07-10	0° ± 2'	XXXX+0020/XXX+051			dwg no	
F	V11068	JRW	2001-03-21	dr	J.W. BAIR	FCI		sheet 1 of 3 size	
G	V12274	CGD	2001-10-01	engr	S. AURAND			79831 A4	
H	V05-0403	HTB	2005-05-02	chr	S. AURAND			type	
J	V06-0684	HTB	2006-07-25	appd	S. AURAND			CUSTOMER Drawing	
sheet	revision	K	K	K					
index	sheet	1	2	3					

PRODUCT NUMBER  
SEE TABLE

NOTES

- ①. PIN MATERIAL: PHOS. BRONZE 3/4 HARD ASTM B-159-66.
- ②. BURNISH MARKS ON PIN PERMITTED. BURR .003/0.08 MAX TYP  
BULGE .0005 [0.013] MAX TYP.
- 3. SEE PRODUCT SPECIFICATION BUS-14-064 FOR P.C. BOARD  
HOLE DIAMETER AND P.C. BOARD HOLE PLATING INFORMATION.
- ④. PIN TO FERRULE RETENTION 1LB [0.45Kg] MIN TO 6LB [2.72Kg] MAX.
- ⑤. STAR FEATURE SHALL BE CONCENTRIC TO THE WIRE DIAGONAL WITHIN  
.004 [0.10] TIR .039 [0.99] TOLERANCE: +.001,-.002 [+0.03,-0.05]  
.041 [1.04] TOLERANCE: ±.001 [0.03]
- ⑥. .002 [0.05] R MAX TYP 4 PLACES ON WIRE WRAP PORTION OF PIN.
- ⑦. CARRIER STRIP FOR CONVEYING PURPOSES ONLY.
- ⑧. IF B DIM. IS .030 [0.76] OR LESS, THE MAX. FLAT MAY BE .020 [0.05]
- ⑨. TWO SIDES OF LEAD IN NOT PLATED, TYP BOTH ENDS.
- ⑩. USE FIRST TWO DIGITS OF "H" DIMENSION FOR DASH NUMBER OF  
PUNCH FROM MACHINE EPL:  
EXAMPLE: 79831-001 "BD" .062 [1.57] H=.235  
PUNCH P/N FROM EPL  
BP161A-XXXXXX-023  
BP151 -YYYYYY-023  
BP171 -ZZZZZZ-023
- 11. CENTER LINE OF TERMINAL MUST BE IN A TRUE POSITION WITHIN .015 [0.38]  
DIA. WITH RESPECT TO HOLE AXIS AFTER INSERTION IN PC BOARD.
- 12. PIN TIP TO BE TRIM / SWAGE.
- ⑬. ADD AN LF SUFFIX TO PART NUMBER FOR PRODUCT THAT  
MEETS EUROPEAN UNION DIRECTIVES AND OTHER COUNTRY  
REGULATIONS AS DESCRIBED IN GS-22-008.
- ⑭. THIS PRODUCT HAS 100% TIN PLATING IN THE  
INTERFACE AND HAS NOT BEEN TESTED FOR WHISKER  
GROWTH IN ALL INTERCONNECT ENVIRONMENTS.

mat'l. code		surface		tolerance		projection		product family	
SEE NOTE 1		ASME Y14.5		ASME Y14.5				PIN PRODUCTS	
ltr	ecn no	dr	date	tolerances unless otherwise specified				title	
K				angles	XX*.01/X*.3	INCH/MM		BERGPIN® .200"[5.08]cc	
				0°±2'	XXX*.005/XX*.13	scale 3:1		SHORT OVERALL LENGTH	
					XXXX*.0020/XXX*.051			dwg no	
		dr	J.W. BAIR	1991-05-01			sheet 2 of 3		size
		engr	S. AURAND	1991-05-01			79831		A4
		chr	S. AURAND	1991-05-01			type		CUSTOMER Drawing
		appd	S. AURAND	1991-05-01					
sheet index	revision sheet								



PRODUCT NO NOTE 13	OVERALL LENGTH DIM L	CONTACT AREA DIM A	TERM. AREA DIM B	STAR DIA. DIM C	STAR LENGTH DIM D	DIM H FOR .062/ 1.57 BOARD	DIM H FOR 0.93/ 2.36 BOARD	DIM H FOR 1.25/ 3.18 BOARD	CUSTOMER RESTRICTED	PLATING	UNDERPLATING	
79831-001	.210/5.33	.150/3.81	.020/0.51	.039/0.99	.040/1.02	.150/3.81	.135/3.43	.120/3.05	NO	15μ" [0.38μ] MIN Au	50μ" [1.27μ] MIN Ni	DISCONTINUED
79831-001LF												
79831-002	<del>.210/5.33</del>	<del>.150/3.81</del>	<del>.020/0.51</del>	<del>.039/0.99</del>	<del>.040/1.02</del>	<del>.150/3.81</del>	<del>.135/3.43</del>	<del>.120/3.05</del>	<del>NO</del>	120μ" [3.05μ] MIN 93/77 SnPb	50μ" [1.27μ] MIN Ni	
79831-002LF	.210/5.33	.150/3.81	.020/0.51	.039/0.99	.040/1.02	.150/3.81	.135/3.43	.120/3.05	NO	100μ" [2.54μ] MIN Sn (NOTE 14)	50μ" [1.27μ] MIN Ni	
79831-003	.210/5.33	.150/3.81	.020/0.51	.039/0.99	.040/1.02	.150/3.81	.135/3.43	.120/3.05	NO	15μ" [0.38μ] GXT	50μ" [1.27μ] MIN Ni	
79831-003LF												
79831-004	INTERNAL USE ONLY											
79831-005	.275/6.99	.187/4.75	.018/0.46	.041/1.04	.070/1.78	.176/4.47	.160/4.06	.125/3.18	YES	30μ" [0.76μ] MIN Au	50μ" [1.27μ] MIN Ni	
79831-005LF												
79831-006	.292/7.42	.196/4.98	.026/0.66	.041/1.04	.070/1.78	.185/4.70	.169/4.29	.134/3.40	YES	30μ" [0.76μ] MIN Au	50μ" [1.27μ] MIN Ni	
79831-006LF												

mat'l. code		surface		tolerance		projection		product family	
SEE NOTE 1		ASME Y14.5		ASME Y14.5				PIN PRODUCTS	
ltr	ecn no	dr	date	tolerances unless otherwise specified		INCH/MM		title	
K				angles	XX+01/XX+3			BERGPIN® .200"[5.08]cc	
				0°±2'	XXX+005/XXX+13	scale 2:1		SHORT OVERALL LENGTH	
					XXXX+0020/XXX+051			dwg no	
		dr	J.W. BAIR	1991-05-01				sheet 3 of 3 size	
		engr	S. AURAND	1991-05-01				79831 A4	
		chr	S. AURAND	1991-05-01				type	
		appd	S. AURAND	1991-05-01				CUSTOMER Drawing	
sheet index	revision sheet								