

ON Semiconductor

Is Now

onsemi™

To learn more about onsemi™, please visit our website at
www.onsemi.com

onsemi and **onsemi** and other names, marks, and brands are registered and/or common law trademarks of Semiconductor Components Industries, LLC dba "**onsemi**" or its affiliates and/or subsidiaries in the United States and/or other countries. **onsemi** owns the rights to a number of patents, trademarks, copyrights, trade secrets, and other intellectual property. A listing of **onsemi** product/patent coverage may be accessed at www.onsemi.com/site/pdf/Patent-Marking.pdf. **onsemi** reserves the right to make changes at any time to any products or information herein, without notice. The information herein is provided "as-is" and **onsemi** makes no warranty, representation or guarantee regarding the accuracy of the information, product features, availability, functionality, or suitability of its products for any particular purpose, nor does **onsemi** assume any liability arising out of the application or use of any product or circuit, and specifically disclaims any and all liability, including without limitation special, consequential or incidental damages. Buyer is responsible for its products and applications using **onsemi** products, including compliance with all laws, regulations and safety requirements or standards, regardless of any support or applications information provided by **onsemi**. "Typical" parameters which may be provided in **onsemi** data sheets and/or specifications can and do vary in different applications and actual performance may vary over time. All operating parameters, including "Typicals" must be validated for each customer application by customer's technical experts. **onsemi** does not convey any license under any of its intellectual property rights nor the rights of others. **onsemi** products are not designed, intended, or authorized for use as a critical component in life support systems or any FDA Class 3 medical devices or medical devices with a same or similar classification in a foreign jurisdiction or any devices intended for implantation in the human body. Should Buyer purchase or use **onsemi** products for any such unintended or unauthorized application, Buyer shall indemnify and hold **onsemi** and its officers, employees, subsidiaries, affiliates, and distributors harmless against all claims, costs, damages, and expenses, and reasonable attorney fees arising out of, directly or indirectly, any claim of personal injury or death associated with such unintended or unauthorized use, even if such claim alleges that **onsemi** was negligent regarding the design or manufacture of the part. **onsemi** is an Equal Opportunity/Affirmative Action Employer. This literature is subject to all applicable copyright laws and is not for resale in any manner. Other names and brands may be claimed as the property of others.



6-Bit Programmable 2- to 4-Phase Synchronous Buck Controller

ADP3196

FEATURES

- Selectable 2-, 3-, or 4-phase operation at up to 1 MHz per phase**
- ±10 mV worst-case differential sensing error over temperature**
- Logic-level PWM outputs for interface to external high power drivers**
- Enhanced PWM flex mode for excellent load transient performance**
- Active current balancing between all output phases**
- Built-in power-good/crowbar blanking supports on-the-fly VID code changes**
- Digitally programmable 0.3750 V to 1.55 V output**
- Programmable short-circuit protection with programmable latch-off delay**

APPLICATIONS

- Desktop PC power supplies for next generation AMD processors**
- VRM modules**

GENERAL DESCRIPTION

The ADP3196¹ is a highly efficient multiphase synchronous buck switching regulator controller optimized for converting a 12 V main supply into the core supply voltage required by high performance Advanced Micro Devices, Inc. (AMD) processors. It uses an internal 6-bit DAC to read a voltage identification (VID) code directly from the processor, which is used to set the output voltage between 0.3750 V and 1.55 V.

This device uses a multimode PWM architecture to drive the logic-level outputs at a programmable switching frequency that can be optimized for VR size and efficiency. The phase relationship of the output signals can be programmed to provide 2-, 3-, or 4-phase operation, allowing for the construction of up to four complementary buck switching stages.

The ADP3196 supports a programmable slope function to adjust the output voltage as a function of the load current so that it is always optimally positioned for a system transient. This can be disabled by connecting Pin LLSET to Pin CSREF.

¹Protected by U.S. Patent Number 6,683,441; others patents pending.

FUNCTIONAL BLOCK DIAGRAM

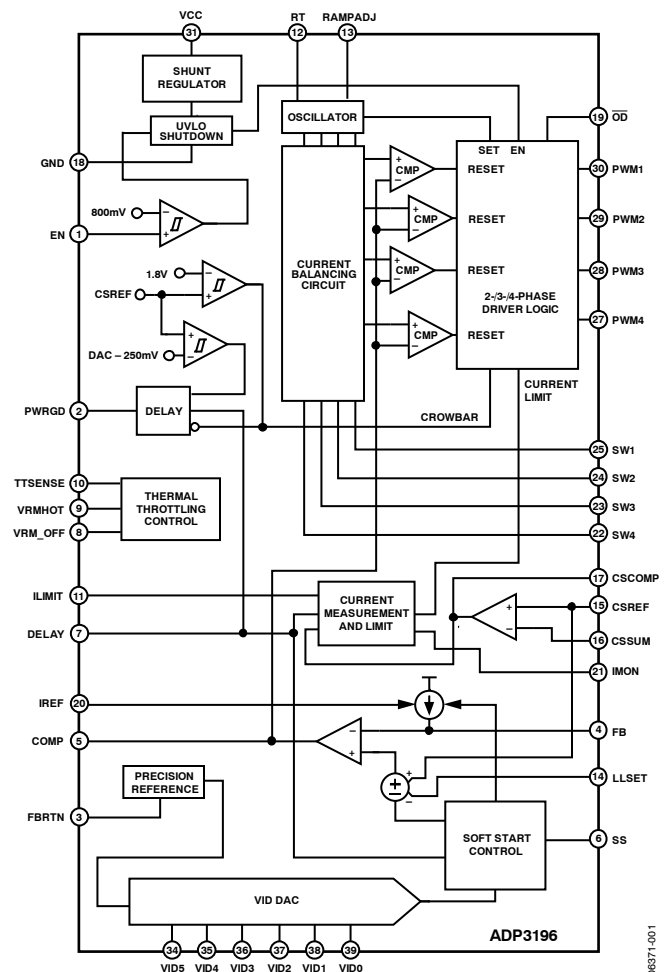

Figure 1. Functional Block Diagram

The ADP3196 also provides accurate and reliable short-circuit protection, adjustable current limiting, and a delayed power-good output that accommodates on-the-fly output voltage changes requested by the CPU. The ADP3196 has a built-in shunt regulator that allows the part to be connected to the 12 V system supply through a series resistor.

The ADP3196 is specified over the extended commercial temperature range of 0°C to +85°C and is available in a 40-lead LFCSP.

TABLE OF CONTENTS

Features.....	1	Output Current Sensing.....	11
Applications	1	Active Impedance Control Mode	11
General Description.....	1	Current Control Mode and Thermal Balance.....	11
Functional Block Diagram.....	1	Voltage Control Mode	12
Table of Contents.....	2	Current Reference.....	12
Revision History.....	2	Enhanced PWM Mode.....	12
Specifications	3	Delay Timer	12
Test Circuits	5	Soft Start.....	12
Absolute Maximum Ratings	6	Current Limit, Short-Circuit, and Latch-Off Protection.....	13
ESD Caution	6	Dynamic VID	14
Pin Configuration and Function Description.....	7	Power-Good Monitoring	14
Typical Performance Characteristics.....	9	Output Crowbar.....	14
Theory of Operation.....	10	Output Enable and UVLO.....	14
Start-Up Sequence	10	Thermal Monitoring.....	14
Phase Detection Sequence	10	Layout and Component Placement.....	17
Master Clock Frequency	11	Outline Dimensions.....	18
Output Voltage Differential Sensing	11	Ordering Guide	18

REVISION HISTORY

01/08 - Rev 1: Conversion to ON Semiconductor

10/06—Revision 0: Initial Version

SPECIFICATIONS

VCC = 5 V, FBRTN = GND, T_A = 0°C to 85°C, unless otherwise noted.¹

Table 1.

Parameter	Symbol	Conditions	Min	Typ	Max	Unit
REFERENCE CURRENT						
Reference Bias Voltage	V _{IREF}			1.5		V
Reference Bias Current	I _{IREF}	R _{IREF} = 100 kΩ	14.25	15	15.75	μA
ERROR AMPLIFIER						
Output Voltage Range ²	V _{COMP}		0.05		4.4	V
Accuracy	V _{FB}	Relative to nominal DAC output, referenced to FBRTN, LLSET = CSREF (see Figure 2)	-10		10	mV
Load Line Positioning Accuracy		CSREF - LLSET = 80 mV	-78	-80	-82	mV
Differential Nonlinearity			-1		+1	LSB
Input Bias Current	I _{FB}	I _{FB} = 0.5 × I _{IREF}	-9	-7.5	-6	μA
FBRTN Current	I _{FBRTN}			65	200	μA
Output Current	I _{COMP}	FB forced to V _{OUT} - 3%		500		μA
Gain Bandwidth Product	GBW _(ERR)	COMP = FB		20		MHz
Slew Rate		COMP = FB		25		V/μs
LLSET Input Voltage Range	V _{LLSET}	Relative to CSREF	-250		+250	mV
LLSET Input Bias Current	I _{LLSET}		-10		+10	nA
VID INPUTS						
Input Low Voltage	V _{IL(VID)}	VID(X), VIDSEL			0.6	V
Input High Voltage	V _{IH(VID)}	VID(X), VIDSEL	1.4			V
Input Current	I _{IN(VID)}			-10		μA
VID Transition Delay Time ²		VID code change to FB change	400			ns
OSCILLATOR						
Frequency Range ²	f _{OSC}		0.25		4	MHz
Frequency Variation	f _{PHASE}	T _A = 25°C, R _T = 205 kΩ, 4 phase	180	200	220	kHz
		T _A = 25°C, R _T = 118 kΩ, 4 phase		400		kHz
		T _A = 25°C, R _T = 55 kΩ, 4 phase		800		kHz
Output Voltage	V _{RT}	R _T = 243 kΩ to GND	1.9	2.0	2.1	V
RAMPADJ Output Voltage	V _{RAMPADJ}	RAMPADJ - FB, DAC = 1.55 V	-50		+50	mV
RAMPADJ Input Current Range	I _{RAMPADJ}		1		50	μA
CURRENT SENSE AMPLIFIER						
Offset Voltage	V _{OS(CSA)}	CSSUM - CSREF (see Figure 3)	-1.0		+1.0	mV
Input Bias Current	I _{BIAS(CSSUM)}		-10		+10	nA
Gain Bandwidth Product	GBW _(CSA)	CSSUM = CSCOMP		10		MHz
Slew Rate		C _{CSCOMP} = 10 pF		10		V/μs
Input Common-Mode Range		CSSUM and CSREF	0		3.5	V
Output Voltage Range			0.05		3.5	V
Output Current	I _{CSCOMP}			500		μA
Current Limit Latch-Off Delay Time	t _{OC(DELAY)}	C _{DELAY} = 10 nF		8		ms
I _{MON} Output	I _{MON}	10 × (CSREF - CSCOMP) > 50mV	-6		+6	%
CURRENT BALANCE AMPLIFIER						
Common-Mode Range	V _{SW(X)CM}		-600		+200	mV
Input Resistance	R _{SW(X)}	SW(X) = 0 V	10	17	26	kΩ
Input Current	I _{SW(X)}	SW(X) = 0 V	8	12	20	μA
Input Current Matching	ΔI _{SW(X)}	SW(X) = 0 V	-4		+4	%
CURRENT LIMIT COMPARATOR						
ILIMIT Bias Current	I _{LIMIT}	I _{LIMIT} = 2/3 × I _{IREF}	9	10	11	μA
ILIMIT Voltage	V _{LIMIT}	R _{LIMIT} = 121kΩ (V _{LIMIT} = I _{LIMIT} × R _{LIMIT})	1.09	1.21	1.33	V
Maximum Output Voltage			3			V
Current Limit Threshold Voltage	V _{CL}	V _{CSREF} - V _{CSCOMP} , R _{LIMIT} = 121 kΩ	80	100	125	mV
Current Limit Setting Ratio		V _{CL} /I _{LIMIT}		82.6		mV/V

ADP3196

Parameter	Symbol	Conditions	Min	Typ	Max	Unit
DELAY TIMER						
Normal Mode Output Current	I_{DELAY}	$I_{DELAY} = I_{REF}$	12	15	18	μA
Output Current in Current Limit	$I_{DELAY(CL)}$	$I_{DELAY(CL)} = 0.25 \times I_{REF}$	3.0	3.75	4.5	μA
Threshold Voltage	$V_{DELAY(TH)}$		1.6	1.7	1.8	V
SOFT START						
Output Current (Startup)	$I_{SS(STARTUP)}$	During startup, $I_{SS(STARTUP)} = 0.25 \times I_{REF}$	3	3.75	4.5	μA
Output Current (DAC Code Change)	$I_{SS(DAC)}$	DAC code change, $I_{SS(DAC)} = 1.25 \times I_{REF}$	15	18.75	22.5	μA
ENABLE INPUT						
Threshold Voltage	$V_{TH(EN)}$		750	800	850	mV
Hysteresis	$V_{HYS(EN)}$		80	100	125	mV
Input Current	$I_{IN(EN)}$			-1		μA
Delay Time	$t_{DELAY(EN)}$	$EN > 950 \text{ mV}$, $C_{DELAY} = 10 \text{ nF}$		2		ms
OD OUTPUT						
Output Low Voltage	$V_{OL(OD)}$			160	500	mV
Output High Voltage	$V_{OH(OD)}$		4	5		V
\overline{OD} Pull-Down Resistor				60		k Ω
THERMAL THROTTLING CONTROL						
TTSENSE Voltage Range		Internally limited	0		5	V
TTSENSE Bias Current			-135	-123	-111	μA
TTSENSE VRM_OFF Threshold Voltage			1.06	1.105	1.15	V
TTSENSE VRMHOT Threshold Voltage			765	810	855	mV
TTSENSE Hysteresis				50		mV
VRM_OFF Output Low Voltage	$V_{OL(VRFAN)}$	$I_{VRFAN(SINK)} = -4 \text{ mA}$		150	300	mV
VRMHOT Output Low Voltage	$V_{OL(VRHOT)}$	$I_{VRHOT(SINK)} = -4 \text{ mA}$		150	300	mV
POWER-GOOD COMPARATOR						
Overvoltage Threshold	$V_{PWRGD(OV)}$	Relative to nominal DAC output; DAC = 0.5 V to 1.55 V Relative to nominal DAC output; DAC = 0.375 V to 0.4785 V	200	250	300	mV
Undervoltage Threshold	$V_{PWRGD(UV)}$	Relative to nominal DAC output; DAC = 0.5 V to 1.55 V Relative to nominal DAC output; DAC = 0.375 V to 0.4785 V	-300	-250	-200	mV
Output Low Voltage	$V_{OL(PWRGD)}$	$I_{PWRGD(SINK)} = -4 \text{ mA}$		150	300	mV
Power-Good Delay Time						
During Soft Start ²		$C_{DELAY} = 10 \text{ nF}$		2		ms
VID Code Changing			100	250		μs
VID Code Static				200		ns
Crowbar Trip Point	$V_{CROWBAR}$	Relative to FBRTN	1.75	1.8	1.85	V
Crowbar Delay Time	$t_{CROWBAR}$	Overvoltage to PWM going low				
VID Code Changing			100	250		μs
VID Code Static				400		ns
PWM OUTPUTS						
Output Low Voltage	$V_{OL(PWM)}$	$I_{PWM(SINK)} = -400 \mu A$		160	500	mV
Output High Voltage	$V_{OH(PWM)}$	$I_{PWM(SOURCE)} = 400 \mu A$	4.0	5		V
POWER SUPPLY						
VCC	VCC	$V_{SYSTEM} = 12 \text{ V}$, $R_{SHUNT} = 340 \Omega$ (see Figure 2)	4.65	5	5.55	V
DC Supply Current	I_{VCC}				25	mA
UVLO Turn On Current				6.5	11	mA
UVLO Threshold Voltage	V_{UVLO}	V_{CC} rising	9			V
UVLO Threshold Voltage	V_{UVLO}	V_{CC} falling		4.1		V

¹ All limits at temperature extremes are guaranteed via correlation using standard statistical quality control (SQC).

² Guaranteed by design or bench characterization, not tested in production.

TEST CIRCUITS

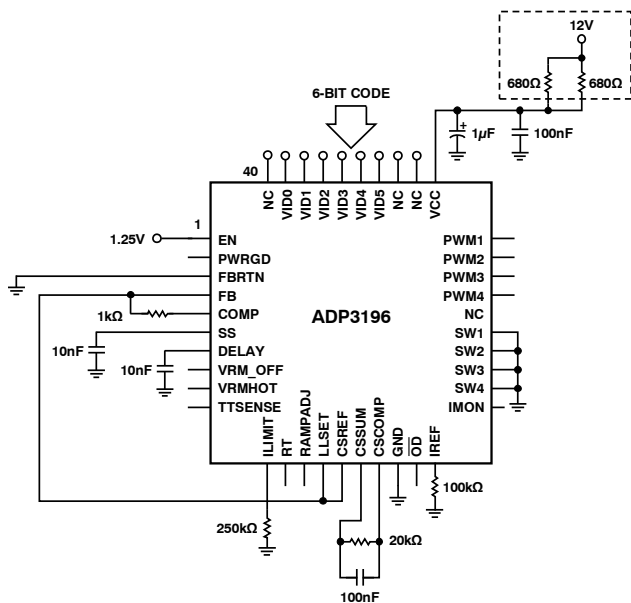

Figure 2. Closed-Loop Output Voltage Accuracy

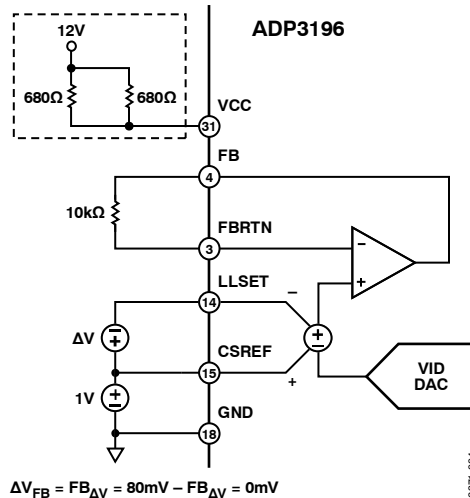

Figure 4. Positioning Voltage

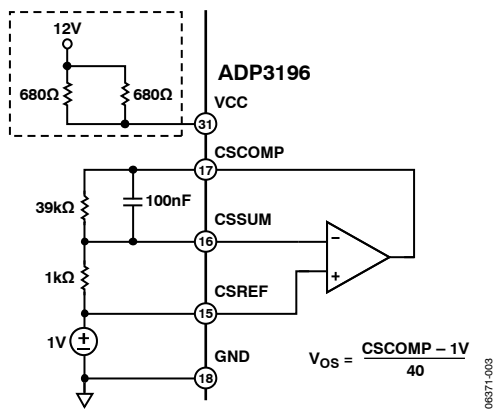

Figure 3. Current Sense Amplifier V_{Os}

ABSOLUTE MAXIMUM RATINGS

Table 2.

Parameter	Rating
VCC	−0.3 V to +6 V
FBRTN	−0.3 V to +0.3 V
PWM3 – PWM4, RAMPADJ	−0.3 V to VCC + 0.3 V
SW1 – SW4	−5 V to +25 V
<200 ns	−10 V to +25 V
All Other Inputs and Outputs	−0.3 V to VCC + 0.3 V
Storage Temperature	−65°C to +150°C
Operating Ambient Temperature Range	0°C to 85°C
Operating Junction Temperature	125°C
Thermal Impedance (θ_{JA})	100°C/W
Lead Temperature	
Soldering (10 sec)	300°C
Infrared (15 sec)	260°C

Stresses above those listed under Absolute Maximum Ratings may cause permanent damage to the device. This is a stress rating only and functional operation of the device at these or any other conditions above those indicated in the operational section of this specification is not implied. Exposure to absolute maximum rating conditions for extended periods may affect device reliability. Absolute maximum ratings apply individually only, not in combination. Unless otherwise specified all other voltages referenced to GND.

ESD CAUTION



ESD (electrostatic discharge) sensitive device. Charged devices and circuit boards can discharge without detection. Although this product features patented or proprietary protection circuitry, damage may occur on devices subjected to high energy ESD. Therefore, proper ESD precautions should be taken to avoid performance degradation or loss of functionality.

PIN CONFIGURATION AND FUNCTION DESCRIPTION

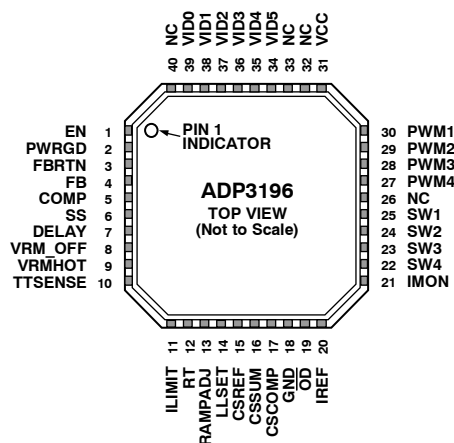

- NOTES
1. NC = NO CONNECT.
 2. THE EXPOSED EPAD ON BOTTOM SIDE OF PACKAGE IS AN ELECTRICAL CONNECTION AND SHOULD BE SOLDERED TO GROUND.

06371-005

Figure 5. Pin Configuration

Table 3. Pin Function Descriptions

Pin No.	Mnemonic	Description
1	EN	Power Supply Enable Input. Pulling this pin to GND disables the PWM outputs and pulls the PWRGD output low.
2	PWRGD	Power-Good Output. Open-drain output that signals when the output voltage is outside of the proper operating range.
3	FBRTN	Feedback Return. VID DAC and error amplifier reference for remote sensing of the output voltage.
4	FB	Feedback Input. Error amplifier input for remote sensing of the output voltage. An external resistor between this pin and the output voltage sets the no load offset point.
5	COMP	Error Amplifier Output and Compensation Point.
6	SS	Soft Start Delay Setting Input. An external capacitor connected between this pin and GND sets the soft start ramp-up time and the VID on-the-fly slew rate.
7	DELAY	Delay Timer Setting Input. An external capacitor connected between this pin and GND sets the overcurrent latch-off delay time, EN delay time, and PWRGD delay time.
8	VRM_OFF	VRM_OFF Signal. Open-drain output that asserts when the temperature at the monitoring point connected to TTSENSE exceeds the VRM_OFF threshold.
9	VRMHOT	Open-drain output that signals when the temperature at the monitoring point connected to TTSENSE exceeds the maximum operating temperature. For example, this can be connected to the PROCHOT# (a PC system signal) output from the CPU.
10	TTSENSE	VR Hot Thermal Throttling Sense Input. An NTC thermistor between this pin and GND is used to remotely sense the temperature at the desired thermal monitoring point.
11	ILIMIT	Current Limit Setpoint. An external resistor from this pin to GND sets the current limit threshold of the converter.
12	RT	Frequency Setting Resistor Input. An external resistor connected between this pin and GND sets the oscillator frequency of the device.
13	RAMPADJ	PWM Ramp Current Input. An external resistor from the converter input voltage to this pin sets the internal PWM ramp.
14	LLSET	Output Load Line Programming Input. This pin can be directly connected to CSCOMP, or it can be connected to the center point of a resistor divider between CSCOMP and CSREF. Connecting LLSET to CSREF disables positioning.
15	CSREF	Current Sense Reference Voltage Input. The voltage on this pin is used as the reference for the current sense amplifier and the power-good and crowbar functions. This pin should be connected to the common point of the output inductors.
16	CSSUM	Current Sense Summing Node. External resistors from each switch node to this pin sum the average inductor currents together to measure the total output current.
17	CSCOMP	Current Sense Compensation Point. A resistor and capacitor from this pin to CSSUM determines the gain of the current sense amplifier and the positioning loop response time.

ADP3196

Pin No.	Mnemonic	Description
18	GND	Ground. All internal biasing and the logic output signals of the device are referenced to this ground.
19	OD	Output Disable Logic Output. This pin is actively pulled low when the ADP3196 EN input is low or when VCC is below its UVLO threshold to signal to the driver IC that the driver high-side and low-side outputs should go low.
20	IREF	Current Reference Input. An external resistor from this pin to ground sets the reference current for I_{FB} , I_{DELAY} , I_{SS} , I_{LIMIT} and I_{TSENSE} .
21	IMON	Analog Output. Represents total load current.
22 to 25	SW4 to SW1	Current Balance Inputs. Inputs for measuring the current level in each phase. The SW pins of unused phases should be left open.
26, 32, 33, 40	NC	No Connection.
27 to 30	PWM4 to PMW1	Logic Level PWM Outputs. Each output is connected to the input of an external MOSFET driver, such as the ADP3120A. Connecting the PWM3 and/or PWM4 outputs to the ADP3196 VCC pin causes that phase to turn off, allowing the ADP3196 to operate as a 2-, 3-, or 4-phase controller.
31	VCC	A 340 Ω resistor should be placed between the 12 V system supply and the VCC pin. The internal shunt regulator maintains VCC = 5 V.
34 to 39	VID5 to VID0	Voltage Code DAC Inputs. These six pins are pulled down to GND, providing a logic zero if left open. When in normal operation mode, the DAC output programs the FB regulation voltage from 0.3750 V and 1.55 V (see Table 4).

TYPICAL PERFORMANCE CHARACTERISTICS

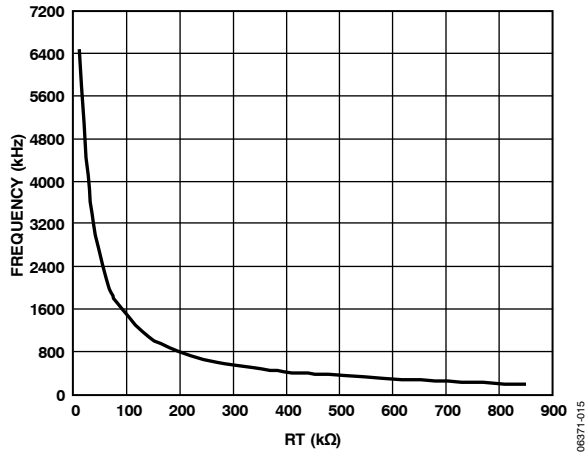

Figure 6. Master Clock Frequency vs. R_T

THEORY OF OPERATION

The ADP3196 combines a multimode, fixed frequency PWM control with multiphase logic outputs for use in 2-, 3-, and 4-phase synchronous buck CPU core supply power converters. The internal VID DAC is designed to interface with the AMD 6-bit CPUs.

Multiphase operation is important for producing the high currents and low voltages demanded by today's microprocessors. Handling the high currents in a single-phase converter places high thermal demands on the components in the system, such as the inductors and MOSFETs.

The multimode control of the ADP3196 ensures a stable, high performance topology for the following:

- Balancing currents and thermals between phases
- High speed response at the lowest possible switching frequency and output decoupling
- Minimizing thermal switching losses by utilizing lower frequency operation
- Tight load line regulation and accuracy
- High current output due to 4-phase operation
- Reduced output ripple due to multiphase cancellation
- PC board layout noise immunity
- Ease of use and design due to independent component selection
- Flexibility in operation for tailoring design to low cost or high performance

START-UP SEQUENCE

The ADP3196 follows the start-up sequence shown in Figure 7. After both the EN and UVLO conditions are met, the DELAY pin goes through one cycle (TD1). The first four clock cycles of TD2 are blanked from the PWM outputs and used for phase detection as explained in the Phase Detection Sequence section. Then, the soft start ramp is enabled (TD2) and the output comes up to the programmed DAC Voltage.

After TD2 has been completed and the PWRGD masking time (equal to VID on-the-fly masking) is finished, a second ramp on the DELAY pin sets the PWRGD blanking (TD3).

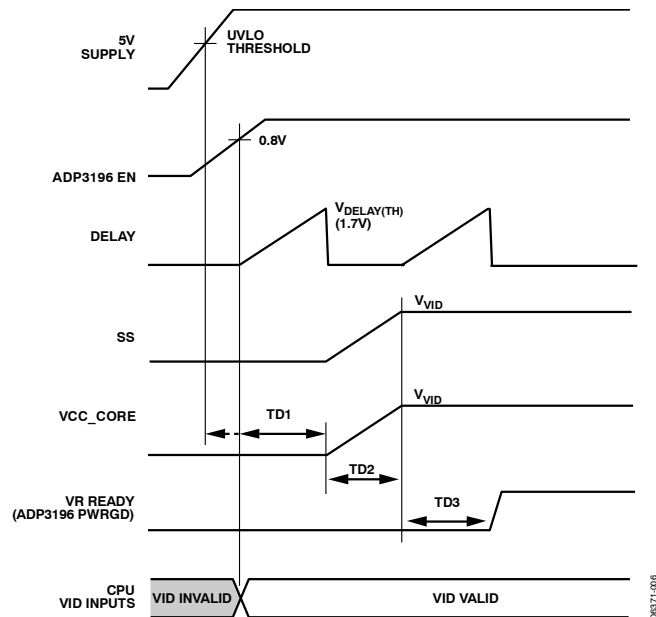

Figure 7. System Start-Up Sequence

PHASE DETECTION SEQUENCE

During startup, the number of operational phases and their phase relationship is determined by the internal circuitry that monitors the PWM outputs. Normally, the ADP3196 operates as a 4-phase PWM controller. Connecting the PWM4 pin to the VCC pin programs 3-phase operation while connecting the PWM4 pin and the PWM3 pin to the VCC pin programs 2-phase operation.

While EN is low and prior to soft start, Pins PWM3 and PWM4 sink approximately 100 μ A. An internal comparator checks the voltage of each pin vs. a threshold of 3 V. If the pin is tied to VCC, it is above the threshold. Otherwise, an internal current sink pulls the pin to GND, which is below the threshold. PWM1 and PWM2 are low during the phase detection interval, which occurs during the first four clock cycles of TD2. After this time, if the remaining PWM outputs are not pulled to VCC, the 100 μ A current sink is removed and they function as normal PWM outputs. If they are pulled to VCC, the 100 μ A current source is removed and the outputs are put into a high impedance state.

The PWM outputs are logic-level devices intended for driving external gate drivers, such as the ADP3120A. Because each phase is monitored independently, operation approaching 100% duty cycle is possible. In addition, more than one output can be on at the same time to allow overlapping phases.

MASTER CLOCK FREQUENCY

The clock frequency of the ADP3196 is set with an external resistor connected from the RT pin to ground. The frequency follows the graph in Figure 6. To determine the frequency per phase, the clock is divided by the number of phases in use. If all phases are in use, divide by 4. If PWM4 is tied to VCC, then divide the master clock by 3 for the frequency of the remaining phases. If PWM3 and PWM4 are tied to VCC, then divide by 2.

OUTPUT VOLTAGE DIFFERENTIAL SENSING

The ADP3196 combines differential sensing with a high accuracy VID DAC and reference and a low offset error amplifier. This maintains a worst-case specification of ± 10 mV differential sensing error over its full operating output voltage and temperature range. The output voltage is sensed between the FB pin and the FBRTN pin. Pin FB should be connected through a resistor to the regulation point, usually the remote sense pin of the microprocessor. Pin FBRTN should be connected directly to the remote sense ground point. The internal VID DAC and precision reference are referenced to FBRTN, which has a minimal current of 65 μ A to allow accurate remote sensing. The internal error amplifier compares the output of the DAC to the FB pin to regulate the output voltage.

OUTPUT CURRENT SENSING

The ADP3196 provides a dedicated current sense amplifier (CSA) to monitor the total output current for proper voltage positioning vs. load current and for current limit detection. Sensing the load current at the output gives the total average current being delivered to the load, which is an inherently more accurate method than peak current detection or sampling the current across a sense element, such as the low-side MOSFET. This amplifier can be configured several ways depending on the objectives of the system as follows:

- Output inductor DCR sensing without a thermistor for lowest cost
- Output inductor DCR sensing with a thermistor for improved accuracy with tracking of inductor temperature
- Sense resistors for highest accuracy measurements

The positive input of the CSA is connected to the CSREF pin, which is connected to the output voltage. The inputs to the amplifier are summed together through resistors from the sensing element, such as the switch node side of the output inductors, to the inverting input, CSSUM. The feedback resistor between CSCOMP and CSSUM sets the gain of the amplifier, and a filter capacitor is placed in parallel with this resistor. The gain of the amplifier is programmable by adjusting the feedback resistor.

An additional resistor divider connected between CSREF and CSCOMP, with the midpoint connected to LLSET, can be used to set the load line required by the microprocessor. The current information is then given as CSREF – LLSET. This difference signal is used internally to offset the VID DAC for voltage positioning. The difference between CSREF and CSCOMP is then used as a differential input for the current-limit comparator. This allows the load line to be set independent of the current-limit threshold. In the event that the current-limit threshold and load line are not independent, the resistor divider between CSREF and CSCOMP can be removed and the CSCOMP pin can be directly connected to the LLSET pin. To disable voltage positioning entirely (that is, no load line), connect LLSET to CSREF.

To provide the best accuracy for sensing current, the CSA is designed to have a low offset input voltage. In addition, the sensing gain is determined by external resistors to make it extremely accurate.

ACTIVE IMPEDANCE CONTROL MODE

For controlling the dynamic output voltage droop as a function of output current, a signal proportional to the total output current at the LLSET pin can be scaled to be equal to the droop impedance of the regulator times the output current. This droop voltage is then used to set the input control voltage to the system. The droop voltage is subtracted from the DAC reference input voltage directly to tell the error amplifier where the output voltage should be. This allows enhanced feed forward response.

CURRENT CONTROL MODE AND THERMAL BALANCE

The ADP3196 has individual inputs (SW1 to SW4) for each phase that are used for monitoring the current in each phase. This information is combined with an internal ramp to create a current balancing feedback system that has been optimized for initial current balance accuracy and dynamic thermal balancing during operation. This current balance information is independent of the average output current information used for positioning described previously in the Output Current Sensing section.

The magnitude of the internal ramp can be set to optimize the transient response of the system. It also monitors the supply voltage for feed forward control for changes in the supply. A resistor connected from the power input voltage to the RAMPADJ pin determines the slope of the internal PWM ramp. External resistors can be placed in series with individual phases to create an intentional current imbalance, if desired, such as when one phase has better cooling and can support higher currents. Resistors R_{SW1} through R_{SW4} (see Figure 11) can be used for adjusting thermal balance. It is best to have the ability to add these resistors during the initial design, therefore, ensure that placeholders are provided in the layout.

To increase the current in any given phase, make R_{SW} for that phase larger (make $R_{SW} = 0$ for the hottest phase and do not change during balancing). Increasing R_{SW} to only 500 Ω makes a substantial increase in phase current. Increase each R_{SW} value by small amounts to achieve balance, starting with the coolest phase first.

VOLTAGE CONTROL MODE

A high gain, high bandwidth voltage mode error amplifier is used for the voltage mode control loop. The control input voltage to the positive input is set via the VID logic according to the voltages listed in Table 4.

The voltage is also offset by the droop voltage for active positioning of the output voltage as a function of current, commonly known as active voltage positioning. The output of the amplifier is the COMP pin, which sets the termination voltage for the internal PWM ramps.

The negative input (FB) is tied to the output sense location with Resistor R_B and is used for sensing and controlling the output voltage at this point. A current source (equal to $I_{REF}/2$) flows through R_B into the FB pin and is used for setting the no load offset voltage from the VID voltage. The no load offset is positive with respect to the VID DAC. The main loop compensation is incorporated into the feedback network between FB and COMP.

CURRENT REFERENCE

The I_{REF} pin is used to set an internal current reference. This reference current sets I_{FB} , I_{DELAY} , I_{SS} , I_{LIMIT} , and I_{TSENSE} . A resistor to ground programs the current based on the 1.5 V output.

$$I_{REF} = \frac{1.5 \text{ V}}{R_{IREF}}$$

Typically, R_{IREF} is set to 100 k Ω to program $I_{REF} = 15 \mu\text{A}$. The following currents are then equal to:

$$I_{FB} = 1/2 (I_{REF}) = 7.5 \mu\text{A}$$

$$I_{DELAY} = I_{REF} = 15 \mu\text{A}$$

$$I_{SS(STARTUP)} = 1/4 (I_{REF}) = 3.75 \mu\text{A}$$

$$I_{SS(DAC)} = 5/4 (I_{REF}) = 18.75 \mu\text{A}$$

$$I_{LIMIT} = 2/3 (I_{REF}) = 10 \mu\text{A}$$

$$I_{TSENSE} = 8 (I_{REF}) = 120 \mu\text{A}$$

ENHANCED PWM MODE

Enhanced PWM mode is intended to improve the transient response of the ADP3196 to a load stepup. In previous generations of controllers, when a load stepup occurred, the controller had to wait until the next turn on of the PWM signal to respond to the load change. Enhanced PWM mode allows the controller to respond immediately when a load stepup occurs. This allows the phases to respond when the load increase transition takes place.

DELAY TIMER

The delay times for the start-up timing sequence are set with a capacitor from the DELAY pin to ground. In UVLO or when EN is logic low, the DELAY pin is held at ground. After the UVLO and EN signals are asserted, the first delay time ($TD1$ in Figure 7) is initiated. A current flows out of the DELAY pin to charge C_{DLY} . This current is equal to I_{REF} , which is normally 15 μA . A comparator monitors the DELAY voltage with a threshold of 1.7 V.

The delay time is therefore set by the I_{REF} current charging a capacitor from 0 V to 1.7 V. This DELAY pin is used for two delay timings ($TD1$ and $TD3$) during the start-up sequence. In addition, DELAY is used for timing the current limit latch off as explained in the Current Limit, Short-Circuit, and Latch-Off Protection section.

SOFT START

The soft start ramp rates for the output voltage are set up with a capacitor from the soft start (SS) pin to ground. During startup, the SS pin sources a current of 3.75 μA . After startup, when a DAC code change occurs, the SS pin sinks or sources an 18.75 μA current to control the rate at which the output voltage can transition up or down.

During startup (after $TD1$ and the phase detection cycle are complete), the SS time ($TD2$ in Figure 7) starts. The SS pin is disconnected from GND and the capacitor is charged up to the programmed DAC voltage by the SS amplifier, which has an output current equal to one quarter I_{REF} (normally 3.75 μA). The voltage at the FB pin follows the ramping voltage on the SS pin, limiting the inrush current during startup. The soft start time depends on the value of the initial DAC voltage and C_{SS} . Note that the DAC code must be set before the ADP3196 is enabled.

Once the SS voltage is within 50 mV of the programmed DAC voltage, the power-good delay time ($TD3$) starts. Once $TD2$ has completed, the soft start current changes to 18.75 μA . If the programmed DAC code changes after startup, then the SS pin sources or sinks a current of 18.75 μA to or from the SS capacitor. This occurs until the SS voltage is within 50 mV of the newly programmed DAC voltage.

If EN is taken low or VCC drops below UVLO, DELAY and SS are reset to ground in preparation for another soft start cycle.

Figure 8 shows typical start-up waveforms for the ADP3196, while Figure 9 shows a typical DAC code change waveform.

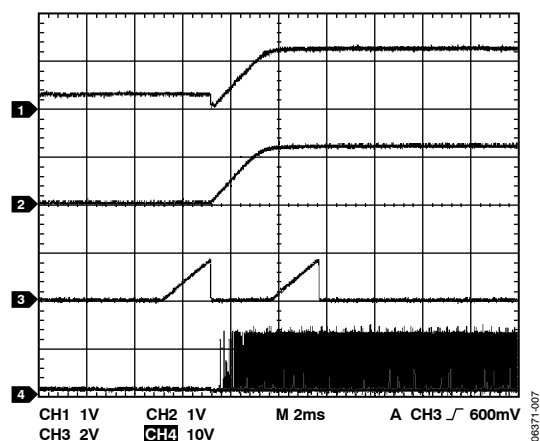

Figure 8. Typical Start-Up Waveforms Channel 1: CSREF, Channel 2: SS, Channel 3: DELAY, Channel 4: Phase 1 Switch Node

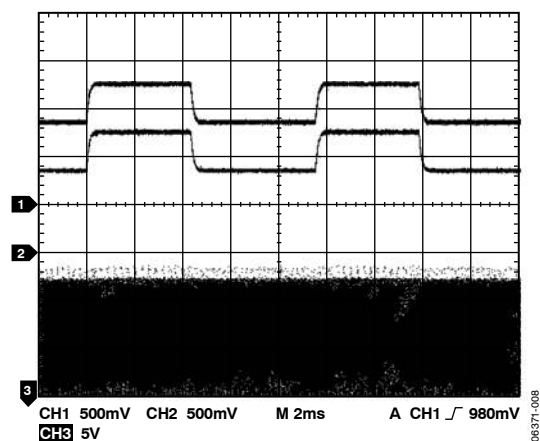

Figure 9. Typical DAC Code Change Waveforms Channel 1: CSREF, Channel 2: SS, Channel 3: Phase 1 Switch Node

CURRENT LIMIT, SHORT-CIRCUIT, AND LATCH-OFF PROTECTION

The ADP3196 compares a programmable current limit setpoint to the voltage from the output of the current sense amplifier. The level of current limit is set with the resistor from the ILIMIT pin to ground. During operation, the current from ILIMIT is equal to $2/3$ of IREF, giving $10\ \mu\text{A}$ normally.

This current, through the external resistor, sets the ILIMIT voltage, which is internally scaled to give a current limit threshold of $82.6\ \text{mV/V}$. If the difference in voltage between CSREF and CSCOMP rises above the current limit threshold, the internal current limit amplifier controls the internal COMP voltage to maintain the average output current at the limit.

If the limit is reached and TD3 has completed, a latch-off delay time starts, and the controller shuts down if the fault is not removed. The current limit delay time shares the DELAY pin timing capacitor with the start-up sequence timing. However, during current limit, the DELAY pin current is reduced to $\text{IREF}/4$.

A comparator monitors the DELAY voltage and shuts off the controller when the voltage reaches $1.7\ \text{V}$. The current limit latch-off delay time is therefore set by the current of $\text{IREF}/4$ charging the delay capacitor from $0\ \text{V}$ to $1.7\ \text{V}$. This delay is four times longer than the delay time during the start-up sequence.

The current limit delay time only starts after the TD3 has completed. If there is a current limit during startup, the ADP3196 goes through TD1 to TD3, and then starts the latch-off time. Because the controller continues to cycle the phases during the latch-off delay time, if the short is removed before the $1.7\ \text{V}$ threshold is reached, the controller returns to normal operation and the DELAY capacitor is reset to GND.

The latch-off function can be reset by either removing and reapplying the supply voltage to the ADP3196, or by toggling the EN pin low for a short time. To disable the short-circuit latch-off function, an external resistor should be placed in parallel with C_{DLY} . This prevents the DELAY capacitor from charging up to the $1.7\ \text{V}$ threshold. The addition of this resistor causes a slight increase in the delay times.

During startup when the output voltage is below $200\ \text{mV}$, a secondary current limit is active. This is necessary because the voltage swing of CSCOMP cannot go below ground. This secondary current limit controls the internal COMP voltage to the PWM comparators to $1.5\ \text{V}$. This limits the voltage drop across the low-side MOSFETs through the current balance circuitry.

An inherent per phase current limit protects individual phases if one or more phases stop functioning because of a faulty component. This limit is based on the maximum normal mode COMP voltage. Typical overcurrent latch-off waveforms are shown in Figure 10.

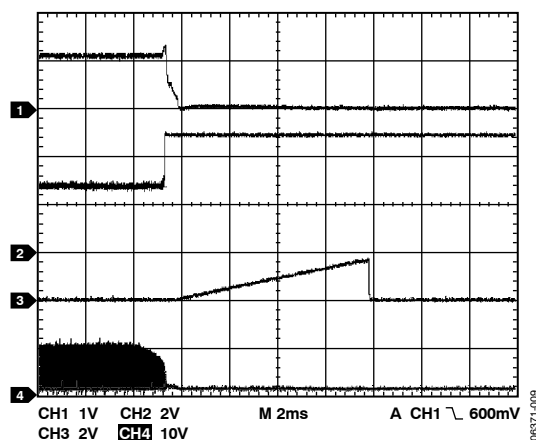

Figure 10. Overcurrent Latch-Off Waveforms Channel 1: CSREF, Channel 2: COMP, Channel 3: DELAY, Channel 4: Phase 1 Switch Node

ADP3196

DYNAMIC VID

The ADP3196 has the ability to respond to dynamically changing VID inputs while the controller is running. This allows the output voltage to change while the supply is running and supplying current to the load. This is commonly referred to as VID on-the-fly (OTF). A VID OTF can occur under either light or heavy load conditions. The processor signals the controller by changing the VID inputs in multiple steps from the start code to the finish code. This change can be positive or negative.

When a VID input changes state, the ADP3196 detects the change and ignores the DAC inputs for a minimum of 400 ns. This time prevents a false code due to logic skew while the six VID inputs are changing. Additionally, the first VID change initiates the PWRGD and CROWBAR blanking functions for a minimum of 100 μ s to prevent a false PWRGD or CROWBAR event. Each VID change resets the internal timer.

POWER-GOOD MONITORING

The power-good comparator monitors the output voltage via the CSREF pin. The PWRGD pin is an open-drain output whose high level, when connected to a pull-up resistor, indicates that the output voltage is within the nominal limits specified based on the VID voltage setting. PWRGD goes low if the output voltage is outside of this specified range, if the VID DAC inputs are in no CPU mode, or if the EN pin is pulled low. PWRGD is blanked during a VID OTF event for a period of 200 μ s to prevent false signals during the time the output is changing.

The PWRGD circuitry also incorporates an initial turn-on delay time (TD3) based on the DELAY timer. Prior to the SS voltage reaching the programmed VID DAC voltage and the PWRGD masking time finishing, the PWRGD pin is held low. Once the SS pin is within 50 mV of the programmed DAC voltage, the capacitor on the DELAY pin begins to charge. A comparator monitors the DELAY voltage and enables PWRGD when the voltage reaches 1.7 V. The PWRGD delay time is set, therefore, by a current of IREF charging a capacitor from 0 V to 1.7 V.

OUTPUT CROWBAR

To protect the load and output components of the supply, the PWM outputs are driven low which turns on the low-side MOSFETs when the output voltage exceeds the upper crowbar threshold.

Turning on the low-side MOSFETs pulls down the output as the reverse current builds up in the inductors. If the output overvoltage is due to a short in the high-side MOSFET, this action current limits the input supply or blows its fuse, protecting the microprocessor from being destroyed.

OUTPUT ENABLE AND UVLO

For the ADP3196 to begin switching, the input supply (VCC) to the controller must be higher than the UVLO threshold, the EN pin must be higher than its 0.8 V threshold, and the DAC code must be valid. This initiates a system start-up sequence. If either UVLO or EN is less than their respective thresholds, the ADP3196 is disabled. This holds the PWM outputs at ground, shorts the DELAY capacitor to ground, and forces PWRGD, and OD signals low.

In the application circuit, the $\overline{\text{OD}}$ pin should be connected to the OD inputs of the ADP3120A drivers. Grounding $\overline{\text{OD}}$ disables the drivers such that both DRVH and DRVL are grounded. This feature is important in preventing the discharge of the output capacitors when the controller is shut off. If the driver outputs are not disabled, a negative voltage can be generated during output due to the high current discharge of the output capacitors through the inductors.

THERMAL MONITORING

The ADP3196 includes a thermal monitoring circuit to detect when a point on the VR has exceeded two different user-defined temperatures. The thermal monitoring circuit requires an NTC thermistor to be placed between TTSENSE and GND. A fixed current of $8 \times \text{IREF}$ (normally giving 123 μ A) is sourced out of the TTSENSE pin and into the thermistor. The current source is internally limited to 5 V. An internal circuit compares the TTSENSE voltage to a 1.105 V and a 0.81 V threshold and outputs an open-drain signal at the VRM_OFF and VRMHOT outputs, respectively.

The VRM_HOT open-drain output goes high once the voltage on the TTSENSE pin goes below the VRM_HOT thresholds and signals the system that an overtemperature event has occurred. The VRM_OFF output asserts when the voltage on the TTSENSE pin exceeds the VRM_OFF threshold. Because the TTSENSE voltage changes slowly with respect to time, 50 mV of hysteresis is built into these comparators. The thermal monitoring circuitry does not depend on EN and is active when UVLO is above its threshold. When UVLO is below its threshold, VRFAN and VRHOT are forced low.

Table 4. VID Codes

OUTPUT	VID5	VID4	VID3	VID2	VID1	VID0
1.550	0	0	0	0	0	0
1.525	0	0	0	0	0	1
1.500	0	0	0	0	1	0
1.475	0	0	0	0	1	1
1.450	0	0	0	1	0	0
1.425	0	0	0	1	0	1
1.400	0	0	0	1	1	0
1.375	0	0	0	1	1	1
1.350	0	0	1	0	0	0
1.325	0	0	1	0	0	1
1.300	0	0	1	0	1	0
1.275	0	0	1	0	1	1
1.250	0	0	1	1	0	0
1.225	0	0	1	1	0	1
1.200	0	0	1	1	1	0
1.175	0	0	1	1	1	1
1.150	0	1	0	0	0	0
1.125	0	1	0	0	0	1
1.100	0	1	0	0	1	0
1.075	0	1	0	0	1	1
1.050	0	1	0	1	0	0
1.025	0	1	0	1	0	1
1.000	0	1	0	1	1	0
0.975	0	1	0	1	1	1
0.950	0	1	1	0	0	0
0.925	0	1	1	0	0	1
0.900	0	1	1	0	1	0
0.875	0	1	1	0	1	1
0.850	0	1	1	1	0	0
0.825	0	1	1	1	0	1
0.800	0	1	1	1	1	0
0.775	0	1	1	1	1	1

OUTPUT	VID5	VID4	VID3	VID2	VID1	VID0
0.7625	1	0	0	0	0	0
0.7500	1	0	0	0	0	1
0.7375	1	0	0	0	1	0
0.7250	1	0	0	0	1	1
0.7125	1	0	0	1	0	0
0.7000	1	0	0	1	0	1
0.6875	1	0	0	1	1	0
0.6750	1	0	0	1	1	1
0.6625	1	0	1	0	0	0
0.6500	1	0	1	0	0	1
0.6375	1	0	1	0	1	0
0.6250	1	0	1	0	1	1
0.6125	1	0	1	1	0	0
0.6000	1	0	1	1	0	1
0.5875	1	0	1	1	1	0
0.5750	1	0	1	1	1	1
0.5625	1	1	0	0	0	0
0.5500	1	1	0	0	0	1
0.5375	1	1	0	0	1	0
0.5250	1	1	0	0	1	1
0.5125	1	1	0	1	0	0
0.5000	1	1	0	1	0	1
0.4875	1	1	0	1	1	0
0.4750	1	1	0	1	1	1
0.4625	1	1	1	0	0	0
0.4500	1	1	1	0	0	1
0.4375	1	1	1	0	1	0
0.4250	1	1	1	0	1	1
0.4125	1	1	1	1	0	0
0.4000	1	1	1	1	0	1
0.3875	1	1	1	1	1	0
0.3750	1	1	1	1	1	1

ADP3196

06971-010

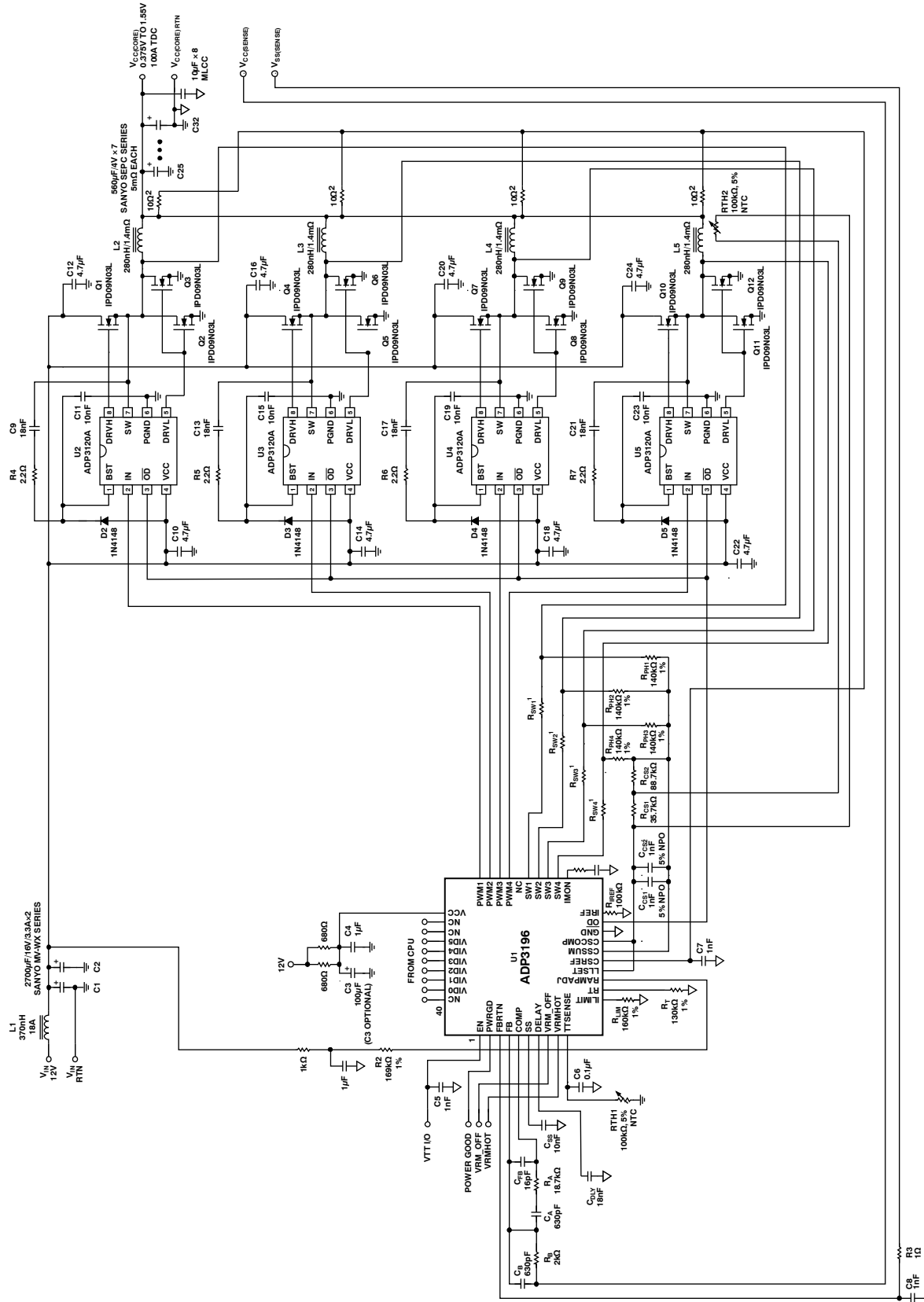

Figure 11. Typical 4-Phase Application Circuit

¹FOR A DESCRIPTION OF OPTIONAL R_{SW} RESISTORS, SEE THE THEORY OF OPERATION SECTION.
²CONNECT NEAR EACH INDUCTOR.

LAYOUT AND COMPONENT PLACEMENT

The following guidelines are recommended for optimal performance of a switching regulator in a PC system.

General Recommendations

For good results, a PCB with at least four layers is recommended. This provides the needed versatility for control circuitry interconnections with optimal placement, power planes for ground, input and output power, and wide interconnection traces in the remainder of the power delivery current paths. Keep in mind that each square unit of 1-ounce copper trace has a resistance of $\sim 0.53 \text{ m}\Omega$ at room temperature.

Whenever high currents must be routed between PCB layers, use vias liberally to create several parallel current paths, so the resistance and inductance introduced by these current paths is minimized and the via current rating is not exceeded.

If critical signal lines (including the output voltage sense lines of the ADP3196) must cross through power circuitry, it is best to interpose a signal ground plane between those signal lines and the traces of the power circuitry. This serves as a shield to minimize noise injection into the signals at the expense of making signal ground a bit noisier.

An analog ground plane should be used around and under the ADP3196 as a reference for the components associated with the controller. This plane should be tied to the nearest output decoupling capacitor ground and should not be tied to any other power circuitry to prevent power currents from flowing into it.

The components around the ADP3196 should be located close to the controller with short traces. The most important traces to keep short and away from other traces are the FB pin and CSSUM pin. The output capacitors should be connected as close as possible to the load (or connector), for example, a microprocessor core, that receives the power. If the load is distributed, the capacitors should also be distributed and generally be in proportion to where the load tends to be more dynamic.

Avoid crossing any signal lines over the switching power path loop (described in the Power Circuitry Recommendations section).

Power Circuitry Recommendations

The switching power path should be routed on the PCB to encompass the shortest possible length to minimize radiated

switching noise energy (EMI) and conduction losses in the board. Failure to take proper precautions often results in EMI problems for the entire PC system and noise-related operational problems in the power converter control circuitry. The switching power path is the loop formed by the current path through the input capacitors and the power MOSFETs, including all interconnecting PCB traces and planes. Using short and wide interconnection traces is especially critical in this path for two reasons: it minimizes the inductance in the switching loop, which can cause high energy ringing; and it accommodates the high current demand with minimal voltage loss.

When a power dissipating component, for example, a power MOSFET, is soldered to a PCB, it is recommended to liberally use the vias, both directly on the mounting pad and immediately surrounding it. Two important reasons for this are improved current rating through the vias and improved thermal performance from vias extended to the opposite side of the PCB, where a plane can more readily transfer the heat to the air. Make a mirror image of any pad being used to heat sink the MOSFETs on the opposite side of the PCB to achieve the best thermal dissipation in the air around the board. To further improve thermal performance, use the largest possible pad area.

The output power path should also be routed to encompass a short distance. The output power path is formed by the current path through the inductor, the output capacitors, and the load.

For best EMI containment, a solid power ground plane should be used as one of the inner layers extending fully under all the power components.

Signal Circuitry Recommendations

The output voltage is sensed and regulated between the FB pin and the FBRTN pin, which connect to the signal ground at the load. To avoid differential mode noise pickup in the sensed signal, the loop area should be small. Thus, the FB trace and FBRTN trace should be routed adjacent to each other on top of the power ground plane back to the controller.

The feedback traces from the switch nodes should be connected as close as possible to the inductor. The CSREF signal should be connected to the output voltage at the nearest inductor to the controller.

OUTLINE DIMENSIONS

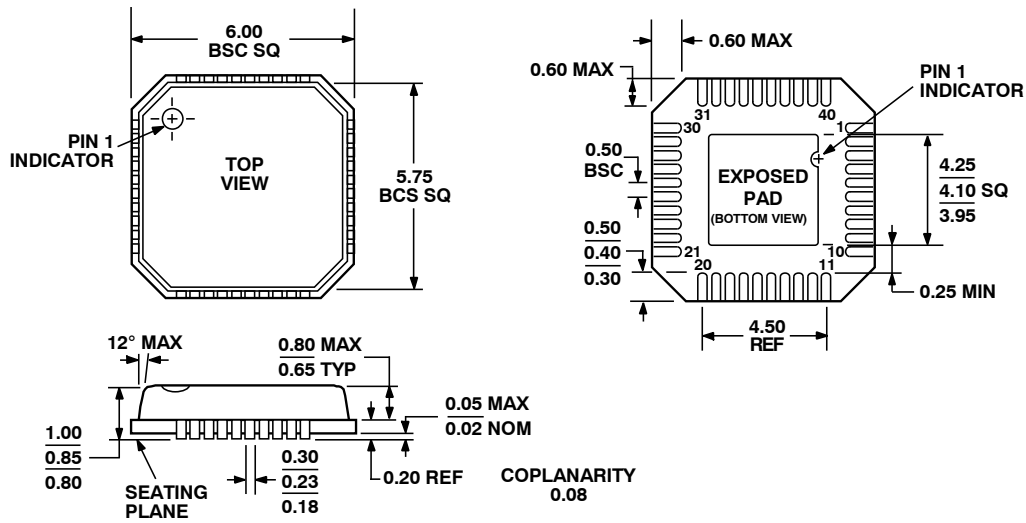

COMPLIANT TO JEDEC STANDARDS MO-220-VJJD-2

Figure 12. 40-Lead Lead Frame Chip Scale Package [LFCSP_VQ]
 6 mm × 6 mm Body, Very Thin Quad
 (CP-40)
 Dimensions shown in millimeters

ORDERING GUIDE

Model	Temperature Range	Package Description	Package Option	Ordering Qty
ADP3196JCPZ-RL ¹	0°C to 85°C	40-Lead Lead Frame Chip Scale Package [LFCSP_VQ]	CP-40	2,500

¹ Z= Pb-free part.

ON Semiconductor and are registered trademarks of Semiconductor Components Industries, LLC (SCILLC). SCILLC reserves the right to make changes without further notice to any products herein. SCILLC makes no warranty, representation or guarantee regarding the suitability of its products for any particular purpose, nor does SCILLC assume any liability arising out of the application or use of any product or circuit, and specifically disclaims any and all liability, including without limitation special, consequential or incidental damages. "Typical" parameters which may be provided in SCILLC data sheets and/or specifications can and do vary in different applications and actual performance may vary over time. All operating parameters, including "Typicals" must be validated for each customer application by customer's technical experts. SCILLC does not convey any license under its patent rights nor the rights of others. SCILLC products are not designed, intended, or authorized for use as components in systems intended for surgical implant into the body, or other applications intended to support or sustain life, or for any other application in which the failure of the SCILLC product could create a situation where personal injury or death may occur. Should Buyer purchase or use SCILLC products for any such unintended or unauthorized application, Buyer shall indemnify and hold SCILLC and its officers, employees, subsidiaries, affiliates, and distributors harmless against all claims, costs, damages, and expenses, and reasonable attorney fees arising out of, directly or indirectly, any claim of personal injury or death associated with such unintended or unauthorized use, even if such claim alleges that SCILLC was negligent regarding the design or manufacture of the part. SCILLC is an Equal Opportunity/Affirmative Action Employer. This literature is subject to all applicable copyright laws and is not for resale in any manner.

PUBLICATION ORDERING INFORMATION

LITERATURE FULFILLMENT:
 Literature Distribution Center for ON Semiconductor
 P.O. Box 5163, Denver, Colorado 80217 USA
Phone: 303-675-2175 or 800-344-3860 Toll Free USA/Canada
Fax: 303-675-2176 or 800-344-3867 Toll Free USA/Canada
Email: orderlit@onsemi.com

N. American Technical Support: 800-282-9855
 Toll Free USA/Canada
Europe, Middle East and Africa Technical Support:
 Phone: 421 33 790 2910
Japan Customer Focus Center
 Phone: 81-3-5773-3850

ON Semiconductor Website: www.onsemi.com
 Order Literature: <http://www.onsemi.com/orderlit>
 For additional information, please contact your local Sales Representative