

滑轨套件 Sliding Rail Kit

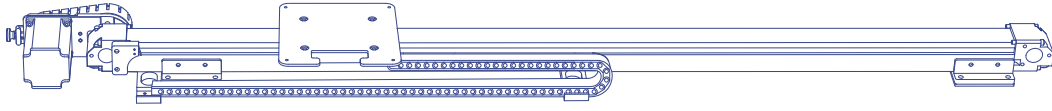

发货清单 Shipping List

滑轨
Sliding Rail



工具套件
Tool Kit

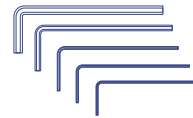

线材套件
Wire Set

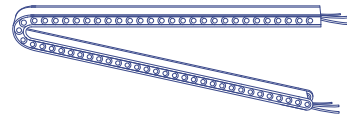

附件
Attachment

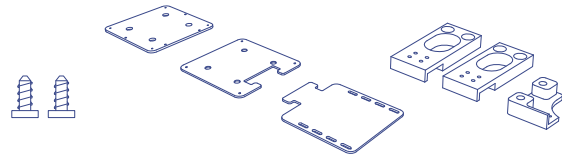

安装说明
Assembly instructions



参数 Specifications

运行负载	Payload	5 kg
有效行程	Effective Travel Distance	1000 mm
最大速度	Maximum Speed	150 mm/s
最大加速度	Maximum Acceleration	150 mm/s ²
重复定位精度	Repeat positioning accuracy	0.01 mm
绝对定位精度	Absolute positioning accuracy	0.25 mm
尺寸 (长×宽×高)	Dimension(L × W × H)	1320mm × 120mm × 55mm
重量	Weight	4.7 kg

安装说明 Assembly instructions

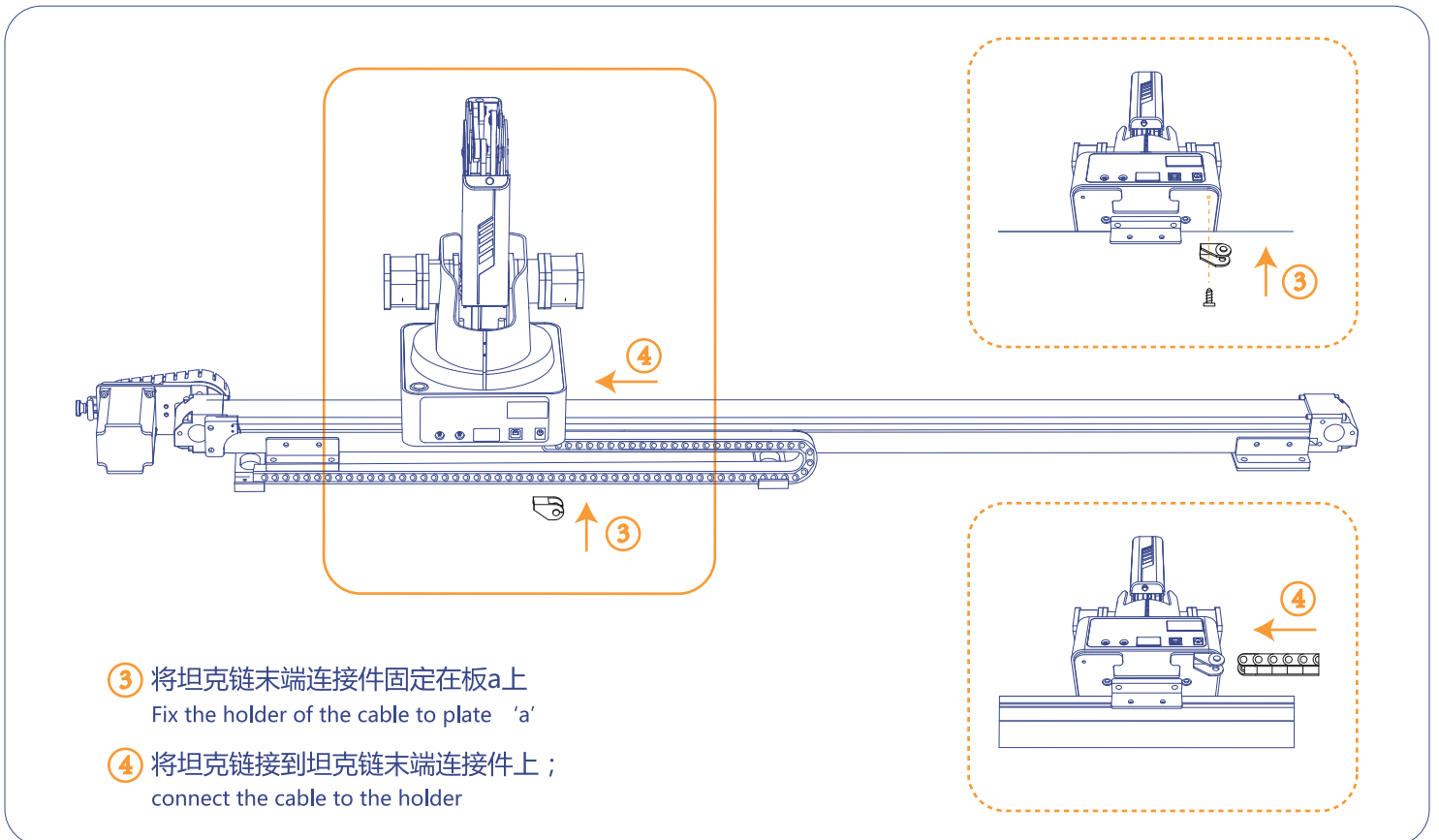
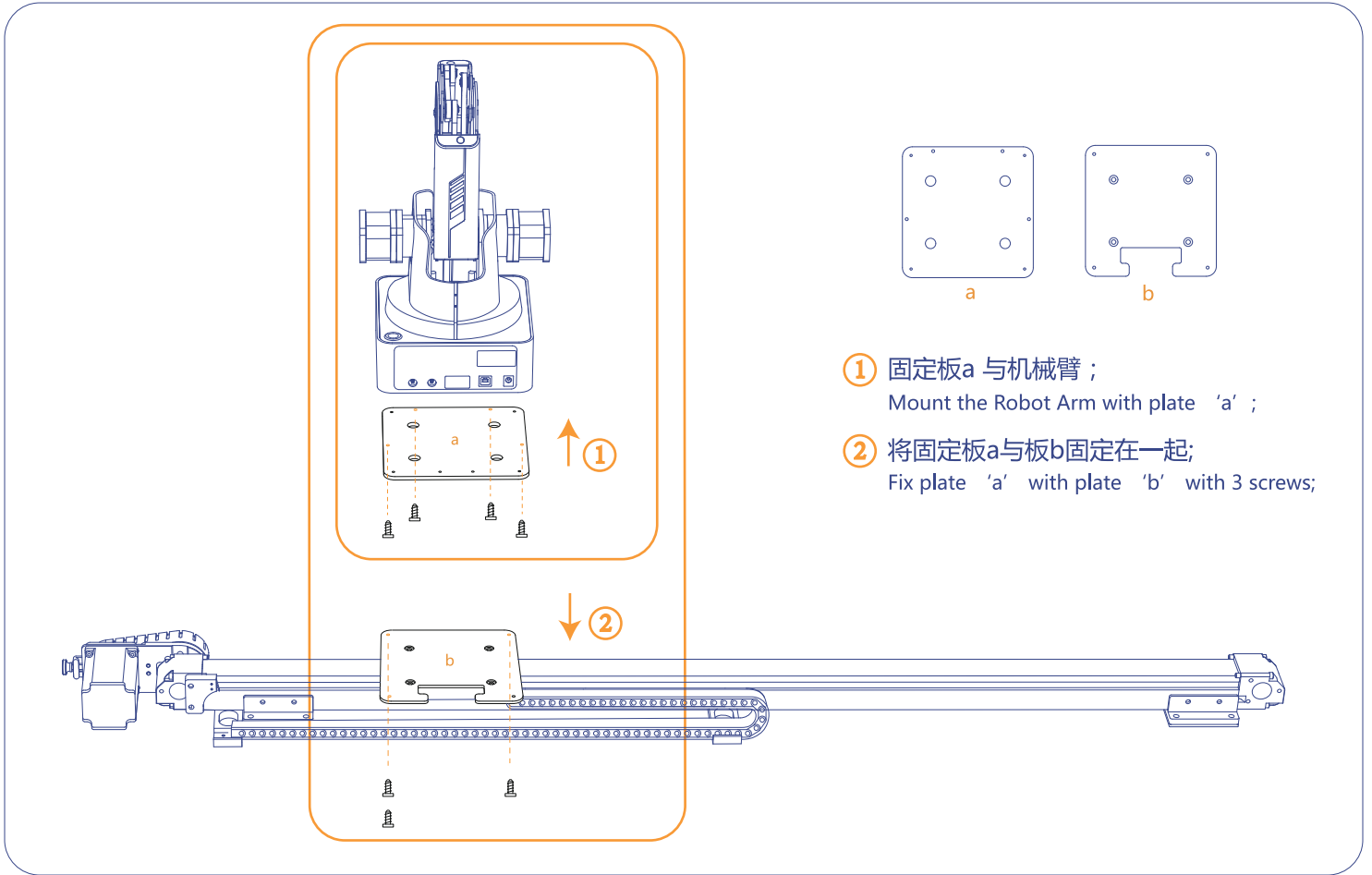

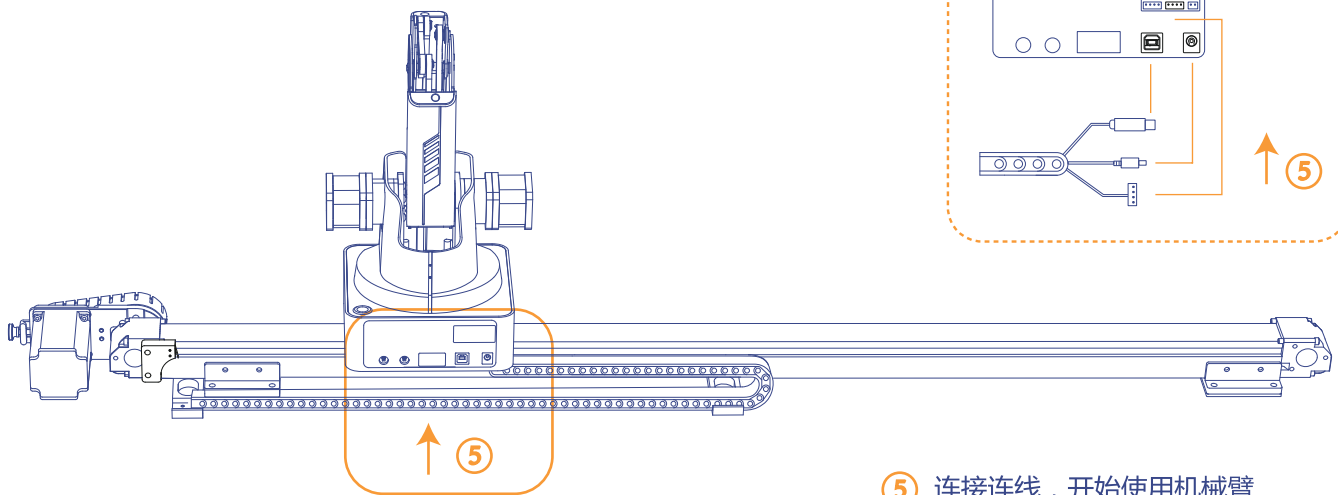

⑤ 连接连线，开始使用机械臂
Connect the cable to the robot and enjoy.

如果需要固定额外的气泵盒，进行搬运应用，可以使用固定板c。

If air pump box is required for other application, you can use plate 'c' to fix it.

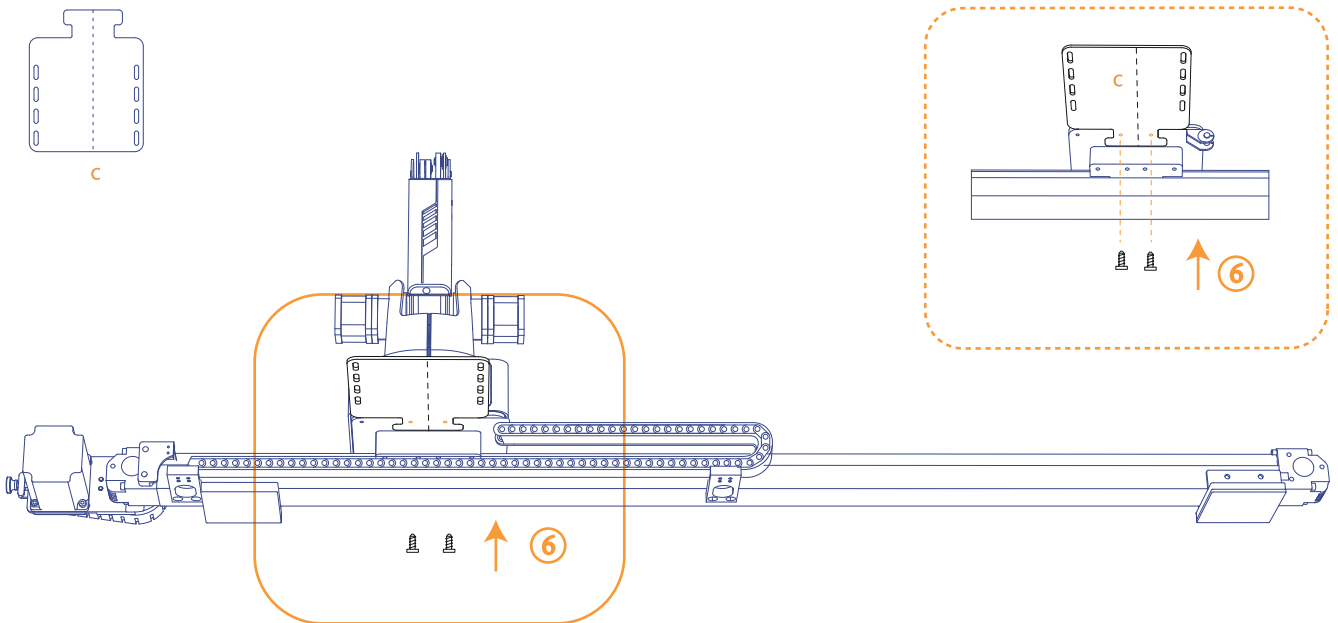

⑥ 用两颗螺丝从底下固定板c到固定板a上;
Use two screws to fix plate 'c' to plate 'a' from bottom;

⑦ 将气泵盒固定在固定板C上。
Fix the air pump box to plate 'c' .

