



# Automotive Signal Common Mode Chokes

ACMS-Q4526C

Request Samples



Check Inventory



4.5 x 3.2 x 2.55 mm  
RoHS/RoHS II Compliant  
MSL Level = 1

## Features

- AEC-Q200 compliant, Grade 1
- PPAP ready and supported
- Manufactured in TS/IATF 16949 production lines
- Excellent impedance characteristics

## Applications

- Differential signal line common mode noise suppression.
- Multimedia devices
- Automotive applications such as ADAS, Infotainment, Sensing, TCU
- Automotive CAN bus

## Electrical Specifications

Part Number	Inductance ( $\mu$ H) (+50%/-30%)	DCR (m $\Omega$ )	Rated Current (A)	Rated Voltage (Vdc)	Insulation Resistance (M $\Omega$ )
		Max	Max	Max	Min
ACMS-Q4526C-110	11	500	0.36	50	10
ACMS-Q4526C-220	22	800	0.31	50	10
ACMS-Q4526C-510	51	1000	0.23	50	10
ACMS-Q4526C-101	100	2000	0.20	50	10

**Rated Current is based on an Irms temperature rise of 20°C**

**Inductance Test Conditions: 100KHz/0.1V**

**ACMS-Q4526C is AEC-Q200 Automotive certified**

**ACMS-Q4526C Series is RoHS Compliant and Pb free**

**Operating Temperature: -40°C to +150°C (Including self-heating)**

**Storage Temperature (on PCB): -40°C to +150°C**

**Storage (in original packaging): <40°C, <70% RH**



5101 Hidden Creek Ln, Spicewood TX 78669  
Phone: 512-371-6159 Fax: 512-351-8858  
For terms and conditions of sales, please visit:  
www.abracon.com

**REVISION Initial Release**  
3/31/2022

ABRACON IS  
ISO9001-2015  
CERTIFIED



# Automotive Signal Common Mode Chokes

ACMS-Q4526C

Request Samples



Check Inventory



4.5 x 3.2 x 2.55 mm  
RoHS/RoHS II Compliant  
MSL Level = 1

## Electrical Specifications

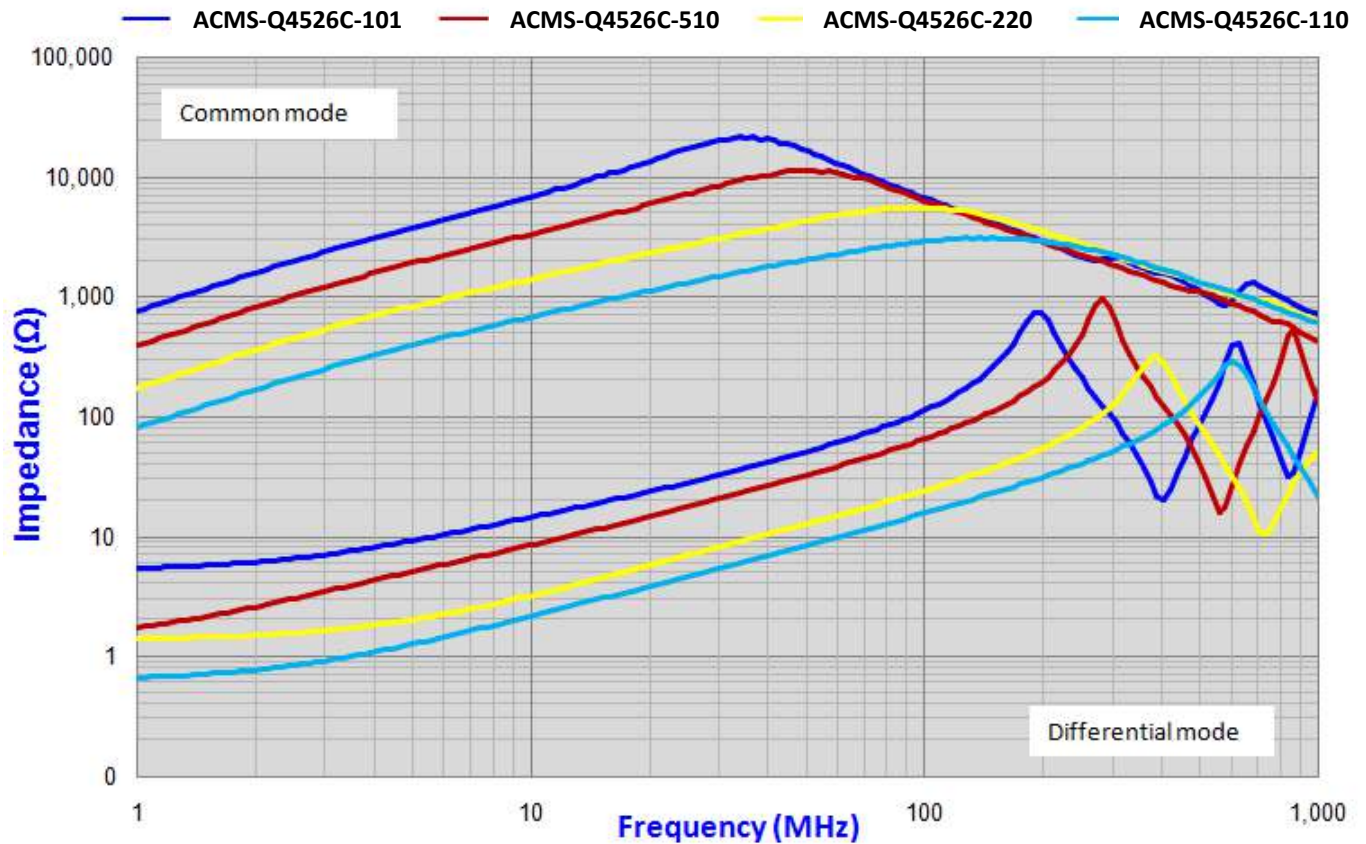

5101 Hidden Creek Ln, Spicewood TX 78669  
Phone: 512-371-6159 Fax: 512-351-8858  
For terms and conditions of sales, please visit:  
[www.abracon.com](http://www.abracon.com)

REVISION Initial Release  
3/31/2022

ABRACON IS  
ISO9001-2015  
CERTIFIED



# Automotive Signal Common Mode Chokes

ACMS-Q4526C

Request Samples



Check Inventory



4.5 x 3.2 x 2.55 mm  
**RoHS/RoHS II Compliant**  
 MSL Level = 1

## Mechanical Specifications

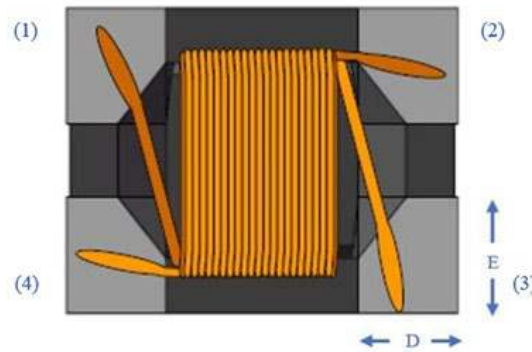
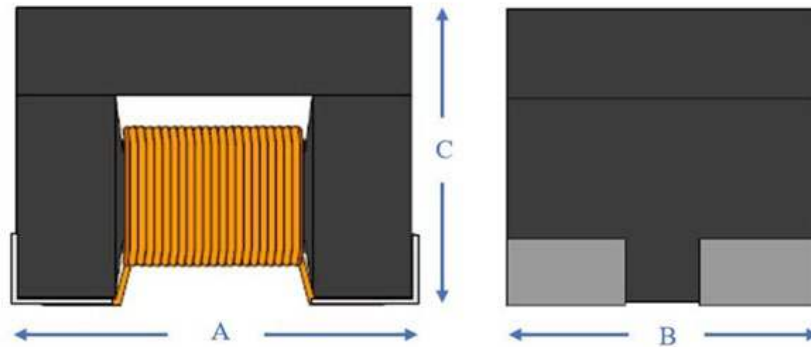

A	B	C	D	E
4.5 ±0.2	3.2 ±0.2	2.55 ±0.2	0.7	0.8

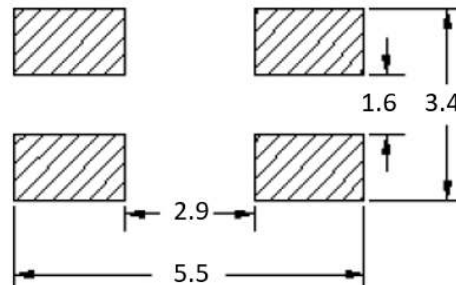

## Recommended Layout

Dimensions: mm



5101 Hidden Creek Ln, Spicewood TX 78669  
 Phone: 512-371-6159 Fax: 512-351-8858  
 For terms and conditions of sales, please visit:  
[www.abracon.com](http://www.abracon.com)

**REVISION Initial Release**  
 3/31/2022

ABRACON IS  
 ISO9001-2015  
 CERTIFIED



# Automotive Signal Common Mode Chokes

**ACMS-Q4526C**

Request Samples



Check Inventory



4.5 x 3.2 x 2.55 mm  
**RoHS/RoHS II Compliant**  
 MSL Level = 1

## Schematic

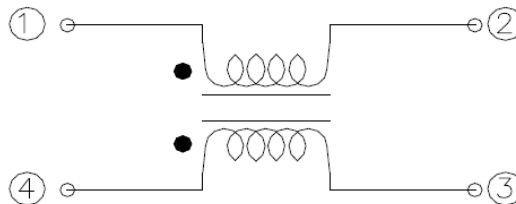

## Materials

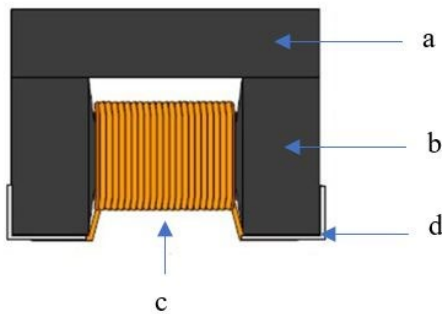

	Description	Specification
a	Upper Plate	Ni-Zn Ferrite
b	Core	Ni-Zn Ferrite
c	Wire	Enameled copper wire
d	Electrode	Ag/Ni/Sn

## Part Identification

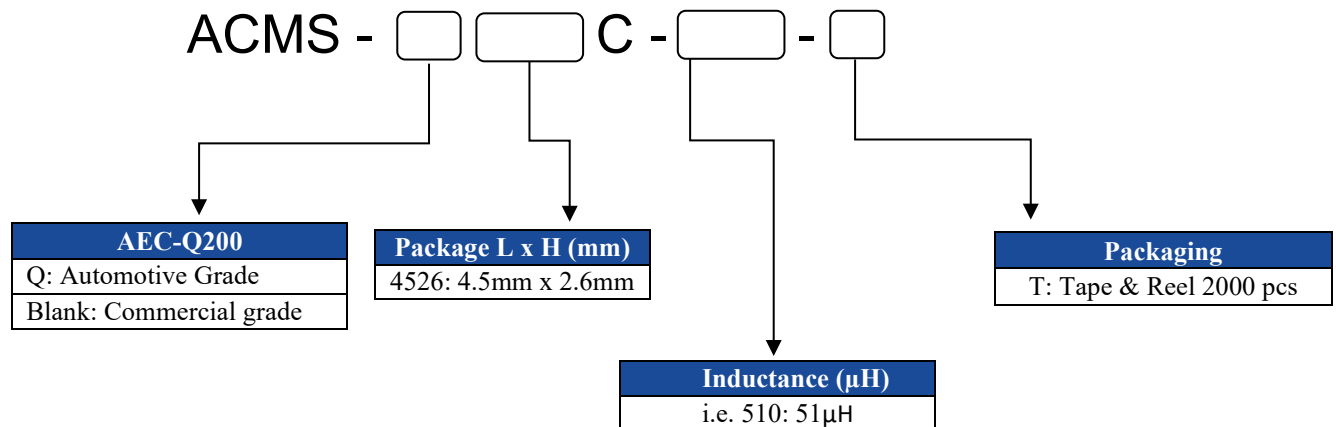



# Automotive Signal Common Mode Chokes

ACMS-Q4526C

Request Samples



Check Inventory



4.5 x 3.2 x 2.55 mm  
 RoHS/RoHS II Compliant  
 MSL Level = 1

## Reflow Profile

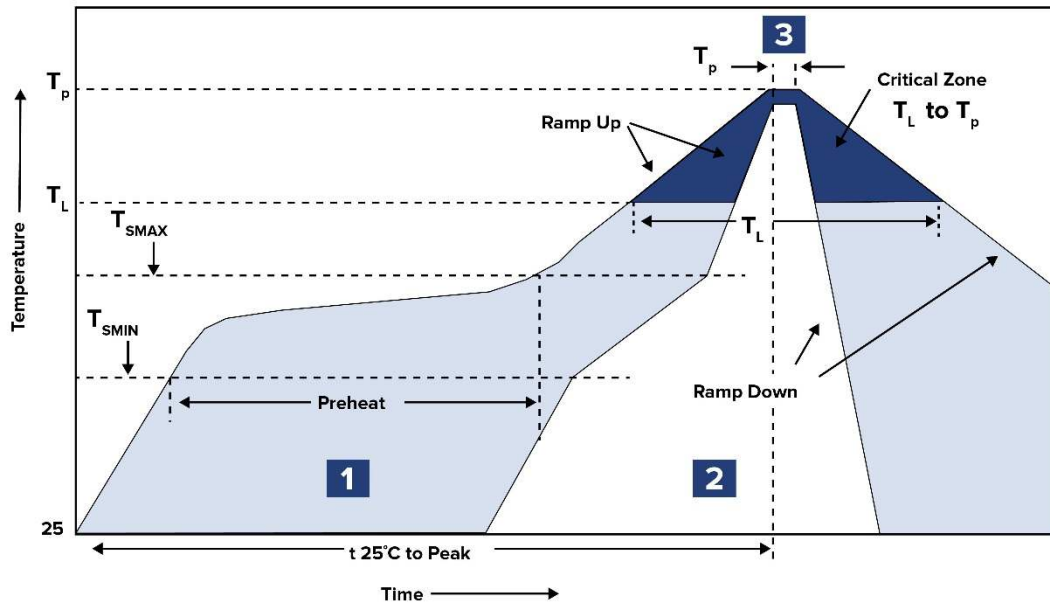

Zone	Description	Temperature	Times
1	Preheat	$T_{SMIN} \sim T_{SMAX}$ 150°C ~ 200°C	60 ~ 120 sec.
2	Reflow	$T_L$ 220°C	60 ~ 90 sec.
3	Peak heat	$T_p$ 260°C MAX	10 sec. MAX



# Automotive Signal Common Mode Chokes

**ACMS-Q4526C**

Request Samples



Check Inventory



4.5 x 3.2 x 2.55 mm  
**RoHS/RoHS II Compliant**  
 MSL Level = 1

## Packaging

**Tape & Reel: 2000pcs/reel**

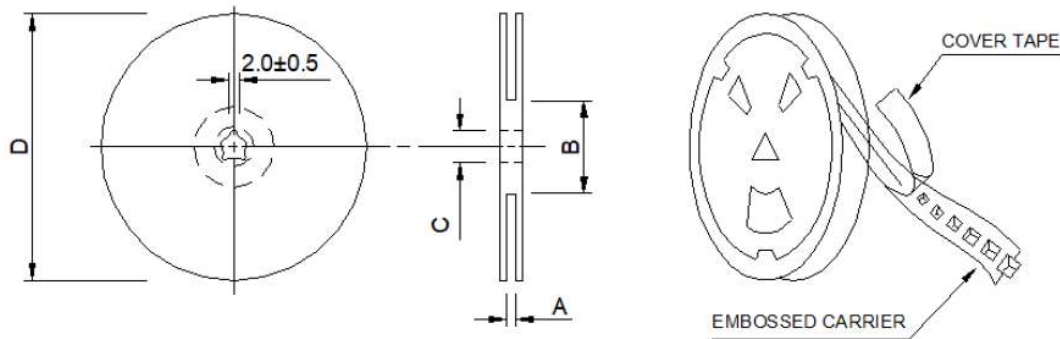

Series	A	B	C	D
ACMS-Q4526C	13.0 ±0.5	100.0 ±2.0	13.0 ±0.5	330

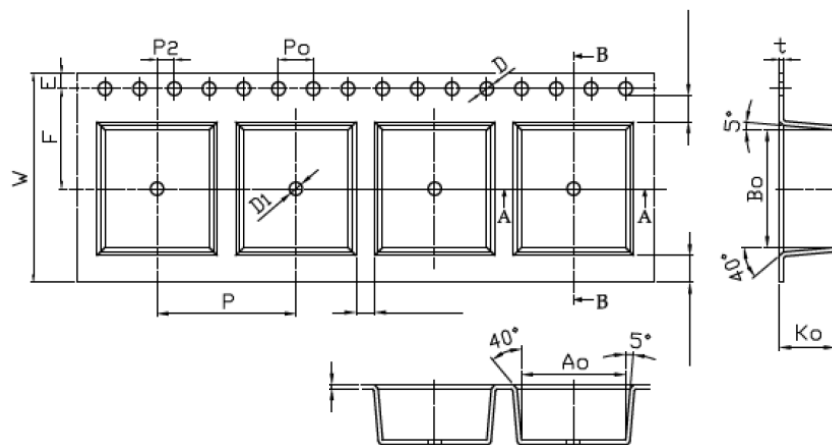

W	P	E	F	P0	P2	Bo	Ao	Ko	D	t
12.0 ±0.30	8.0 ±0.10	1.75 ±0.10	5.5 ±0.10	8.0 ±0.10	4.0 ±0.10	4.82 ±0.10	3.51 ±0.10	3.05 ±0.10	1.5 5+0.10/-0	0.4 ±0.05

Dimensions: mm

**ATTENTION:** Abracon LLC's products are COTS – Commercial-Off-The-Shelf products; suitable for Commercial, Industrial and, where designated, Automotive Applications. Abracon's products are not specifically designed for Military, Aviation, Aerospace, Life-dependent Medical applications or any application requiring high reliability where component failure could result in loss of life and/or property. For applications requiring high reliability and/or presenting an extreme operating environment, written consent and authorization from Abracon LLC is required. Please contact Abracon LLC for more information.



5101 Hidden Creek Ln, Spicewood TX 78669  
 Phone: 512-371-6159 Fax: 512-351-8858  
 For terms and conditions of sales, please visit:  
[www.abracon.com](http://www.abracon.com)

**REVISION Initial Release**  
 3/31/2022

ABRACON IS  
 ISO9001-2015  
 CERTIFIED