

MAX4581L/MAX4582L/ MAX4583L

Low-Voltage, CMOS Analog Multiplexers/Switches

General Description

The MAX4581L/MAX4582L/MAX4583L are low-voltage, CMOS analog ICs configured as an 8-channel multiplexer (MAX4581L), two 4-channel multiplexers (MAX4582L), and three single-pole/double-throw (SPDT) switches (MAX4583L).

These CMOS devices operate with a +2V to +12V single supply. Each switch can handle rail-to-rail analog signals. Off-leakage current is only 2nA at +25°C.

All digital inputs have 0.8V to 2.0V logic thresholds to ensure TTL/CMOS-logic compatibility when using a +12V supply.

Applications

- Audio and Video Signal Routing
- Data-Acquisition Systems
- Communications Circuits
- DSL Modem

Features

- +3V Logic-Compatible Inputs ($V_{IH} = 2.0V$, $V_{IL} = 0.8V$)
- Guaranteed On-Resistance: 80Ω with +12V Supply
- Guaranteed 4Ω On-Resistance Match Between Channels
- Guaranteed Low Off-Leakage Current: 2nA at +25°C
- Guaranteed Low On-Leakage Current: 2nA at +25°C
- +2V to +12V Supply Operation
- TTL/CMOS-Logic Compatible
- Low Crosstalk: -96dB (MAX4582L)
- High Off-Isolation: -90dB
- Tiny 4mm x 4mm Thin QFN Package
- Pin Compatible with Industry-Standard 74HC4051/74HC4052/74HC4053 and MAX4051/MAX4052/MAX4053

Ordering Information

PART	TEMP RANGE	PIN-PACKAGE
MAX4581LESE	-40°C to +85°C	16 Narrow SO
MAX4581LEEE	-40°C to +85°C	16 QSOP
MAX4581LETE	-40°C to +85°C	16 TQFN-EP* (4mm x 4mm)

Ordering Information continued at end of data sheet.

*EP = Exposed pad.

Pin Configurations/Functional Diagrams

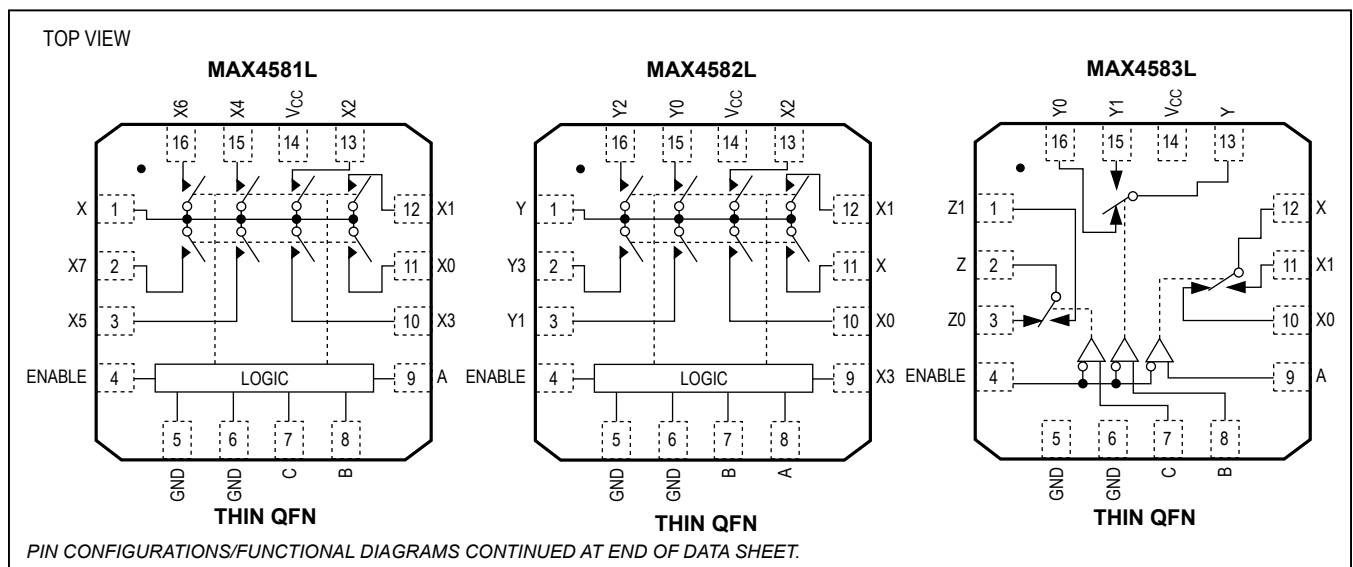

Absolute Maximum Ratings

(All Voltages Referenced to GND, Unless Otherwise Noted.)
 V_{CC}-0.3V to +13V
 Voltage At Any Pin (Note 1).....(GND - 0.3V) to (V_{CC} + 0.3V)
 Continuous Current into Any Terminal.....±20mA
 Peak Current X_{-} , Y_{-} or Z_{-}
 (pulsed at 1ms, 10% duty cycle).....±40mA
 ESD per Method 3015.7.....>2000V

Continuous Power Dissipation ($T_A = +70^{\circ}\text{C}$)
 16-Pin Narrow SO (derate 8.7mW/ $^{\circ}\text{C}$ above +70 $^{\circ}\text{C}$)..696mW
 16-Pin QSOP (derate 8.3mW/ $^{\circ}\text{C}$ above +70 $^{\circ}\text{C}$).....667mW
 16-Pin Thin QFN (derate 16.9mW/ $^{\circ}\text{C}$ above +70 $^{\circ}\text{C}$) 1349mW
 Operating Temperature Range.....-40 $^{\circ}\text{C}$ to +85 $^{\circ}\text{C}$
 Storage Temperature Range.....-65 $^{\circ}\text{C}$ to +150 $^{\circ}\text{C}$
 Junction Temperature.....+150 $^{\circ}\text{C}$
 Lead Temperature (soldering, 10s).....+300 $^{\circ}\text{C}$

Note 1: Voltages exceeding V_{CC} or GND on any signal terminal are clamped by internal diodes. Limit forward-diode current to maximum current rating.

Stresses beyond those listed under "Absolute Maximum Ratings" may cause permanent damage to the device. These are stress ratings only, and functional operation of the device at these or any other conditions beyond those indicated in the operational sections of the specifications is not implied. Exposure to absolute maximum rating conditions for extended periods may affect device reliability.

Electrical Characteristics

($V_{CC} = +12\text{V} \pm 5\%$, $V_H = 2.0\text{V}$, $V_L = 0.8\text{V}$, $T_A = T_{MIN}$ to T_{MAX} , unless otherwise noted. Typical values are at $T_A = +25^{\circ}\text{C}$.) (Notes 2, 3)

PARAMETER	SYMBOL	CONDITIONS	TEMP	MIN	TYPE (NOTE3)	MAX	UNITS	
ANALOG SWITCH								
Analog Signal Range	V_X, V_Y, V_Z		-40 $^{\circ}\text{C}$ to +85 $^{\circ}\text{C}$	0		V_{CC}	V	
Switch On-Resistance	R_{ON}	$V_{CC} = 11.4\text{V}; I_X, I_Y, I_Z = 1\text{mA}; V_X, V_Y, V_Z = 10\text{V}$	+25 $^{\circ}\text{C}$	50		80	Ω	
			-40 $^{\circ}\text{C}$ to +85 $^{\circ}\text{C}$			100		
Switch On-Resistance Match Between Channels	ΔR_{ON}	$V_{CC} = 11.4\text{V}; I_X, I_Y, I_Z = 1\text{mA}; V_X, V_Y, V_Z = 10\text{V}$ (Note 4)	+25 $^{\circ}\text{C}$	1		4	Ω	
			-40 $^{\circ}\text{C}$ to +85 $^{\circ}\text{C}$			5		
Switch On-Resistance Flatness	$R_{FLAT(ON)}$	$V_{CC} = 11.4\text{V}; I_X, I_Y, I_Z = 1\text{mA}; V_{X-}, V_{Y-}, V_{Z-} = 1.5\text{V}, 6\text{V}, 10\text{V}$ (Note 5)	+25 $^{\circ}\text{C}$	5		12	Ω	
			-40 $^{\circ}\text{C}$ to +85 $^{\circ}\text{C}$			15		
X_{-}, Y_{-}, Z_{-} Off-Leakage	$I_{X(OFF)}, I_{Y(OFF)}, I_{Z(OFF)}$	$V_{CC} = 12.6\text{V}; V_{X-}, V_{Y-}, V_{Z-} = 1\text{V}, 10\text{V}; V_X, V_Y, V_Z = 10\text{V}, 1\text{V}$ (Note 6)	+25 $^{\circ}\text{C}$	-2		+2	nA	
			-40 $^{\circ}\text{C}$ to +85 $^{\circ}\text{C}$	-10		+10		
X, Y, Z Off-Leakage	$I_{X(OFF)}, I_{Y(OFF)}, I_{Z(OFF)}$	$V_{CC} = 12.6\text{V}; V_{X-}, V_{Y-}, V_{Z-} = 1\text{V}, 10\text{V}; V_X, V_Y, V_Z = 10\text{V}, 1\text{V}$ (Note 6)	MAX4581L	+25 $^{\circ}\text{C}$	-2		+2	nA
				-40 $^{\circ}\text{C}$ to +85 $^{\circ}\text{C}$	-100		+100	
			MAX4582L/ MAX4583L	+25 $^{\circ}\text{C}$	-2		+2	
				-40 $^{\circ}\text{C}$ to +85 $^{\circ}\text{C}$	-50		+50	
X, Y, Z On-Leakage	$I_{X(ON)}, I_{Y(ON)}, I_{Z(ON)}$	$V_{CC} = 12.6\text{V}; V_{X-}, V_{Y-}, V_{Z-} = 1\text{V}, 10\text{V}; V_X, V_Y, V_Z = 10\text{V}, 1\text{V}$ (Note 6)	MAX4581L	+25 $^{\circ}\text{C}$	-2		+2	nA
				-40 $^{\circ}\text{C}$ to +85 $^{\circ}\text{C}$	-100		+100	
			MAX4582L/ MAX4583L	+25 $^{\circ}\text{C}$	-2		+2	
				-40 $^{\circ}\text{C}$ to +85 $^{\circ}\text{C}$	-50		+50	

Electrical Characteristics (continued)

(V_{CC} = +12V ±5%, V_H = 2.0V, V_L = 0.8V, T_A = T_{MIN} to T_{MAX}, unless otherwise noted. Typical values are at T_A = +25°C.) (Notes 2, 3)

PARAMETER	SYMBOL	CONDITIONS	TEMP	MIN	TYPE (NOTE3)	MAX	UNITS
DIGITAL I/O (INH, ADD_)							
Logic Input High Threshold	V _{AH} , V _{BH} , V _{CH} , V _{ENABLE_H}		-40°C to +85°C		1.5	2.0	V
Logic Input Low Threshold	V _{AL} , V _{BL} , V _{CL} , V _{ENABLE_L}		-40°C to +85°C	0.8	1.5		V
Input Current High	I _{AH} , I _{BH} , I _{CH} , I _{ENABLE_H}	V _A , V _B , V _C , V _{ENABLE} = 2.0V	+25°C	-1		+1	µA
Input Current Low	I _{AL} , I _{BL} , I _{CL} , I _{ENABLE_L}	V _A , V _B , V _C , V _{ENABLE} = 0.8V	+25°C	-1		+1	µA
SWITCH DYNAMIC CHARACTERISTICS							
Enable Turn-On Time	t _{ON}	V _X , V _Y , V _Z = 10V, R _L = 300Ω, C _L = 35pF, Figure 1	+25°C		100	200	ns
			-40°C to +85°C			200	
Enable Turn-Off Time	t _{OFF}	V _X , V _Y , V _Z = 10V, R _L = 300Ω, C _L = 35pF, Figure 1	+25°C		40	100	ns
			-40°C to +85°C			150	
Address Transition Time	t _{TRANS}	V _X , V _Y , V _Z = 10V, R _L = 300Ω, C _L = 35pF, Figure 2	+25°C		90	200	ns
			-40°C to +85°C			200	
Break-Before-Make Time	t _{BBM}	V _X , V _Y , V _Z = 10V, R _L = 300Ω, C _L = 35pF, Figure 3	-40°C to +85°C		20		ns
Charge Injection (Note 7)	Q	C _L = 1nF, R _S = 0Ω, V _S = 0V, Figure 4	+25°C		0.5		pC
Input Off-Capacitance	C _{X(OFF)} , C _{Y(OFF)} , C _{Z(OFF)}	V _X , V _Y , V _Z = 0V, f = 1MHz, Figure 5	+25°C		4		pF
Output Off-Capacitance	C _{X(OFF)} , C _{Y(OFF)} , C _{Z(OFF)}	V _X , V _Y , V _Z = 0V, f = 1MHz, Figure 5	+25°C	MAX4581L		18	pF
				MAX4582L		10	
				MAX4583L		6	
Output On-Capacitance	C _{X(OFF)} , C _{Y(OFF)} , C _{Z(OFF)}	V _X , V _Y , V _Z = 0V, f = 1MHz, Figure 5	+25°C	MAX4581L		25	pF
				MAX4582L		17	
				MAX4583L		12.5	

Electrical Characteristics (continued)

($V_{CC} = +12V \pm 5\%$, $V_{H} = 2.0V$, $V_{L} = 0.8V$, $T_A = T_{MIN}$ to T_{MAX} , unless otherwise noted. Typical values are at $T_A = +25^{\circ}C$.) (Notes 2, 3)

PARAMETER	SYMBOL	CONDITIONS	TEMP	MIN	TYPE (NOTE3)	MAX	UNITS
Off-Isolation	V_{ISO}	$R_L = 50\Omega$, $f = 1MHz$ (Figure 7)	$+25^{\circ}C$		-90		dB
Channel-to-Channel Crosstalk	V_{CT}	$R_L = 50\Omega$, $f = 1MHz$ (Figure 7)	$+25^{\circ}C$		-96		dB
Total Harmonic Distortion	THD	$R_L = 600\Omega$, V_X or V_Y or $V_Z = 5V_{P-P}$, $f = 20Hz$ to $20kHz$	$+25^{\circ}C$		0.02		%
POWER SUPPLY							
Power-Supply Range	V_{CC}			2		12.6	V
Power-Supply Current	I_{CC}	$V_{CC} = 12.6V$; V_A, V_B, V_Z , $V_{ENABLE} = V_{CC}$ or $0V$	$+25^{\circ}C$	-1		+1	μA
			$-40^{\circ}C$ to $+85^{\circ}C$	-10		+10	

Note 2: Thin QFN packages are production tested at $T_A = +85^{\circ}C$. Limits over temperature are guaranteed by design.

Note 3: The algebraic convention used in this data sheet is where the most negative value is the minimum column.

Note 4: $\Delta R_{ON} = R_{ON(MAX)} - R_{ON(MIN)}$.

Note 5: Flatness is defined as the difference between the maximum and minimum value of on-resistance as measured over the specified analog signal ranges.

Note 6: Leakage parameters are 100% tested at the maximum-rated hot operating temperature and guaranteed by design at $T_A = +25^{\circ}C$.

Note 7: Guaranteed by design, not production tested.

Typical Operating Characteristics

($V_{CC} = 12V$, $V_{EN} = GND$, $T_A = +25^{\circ}C$, unless otherwise noted.)

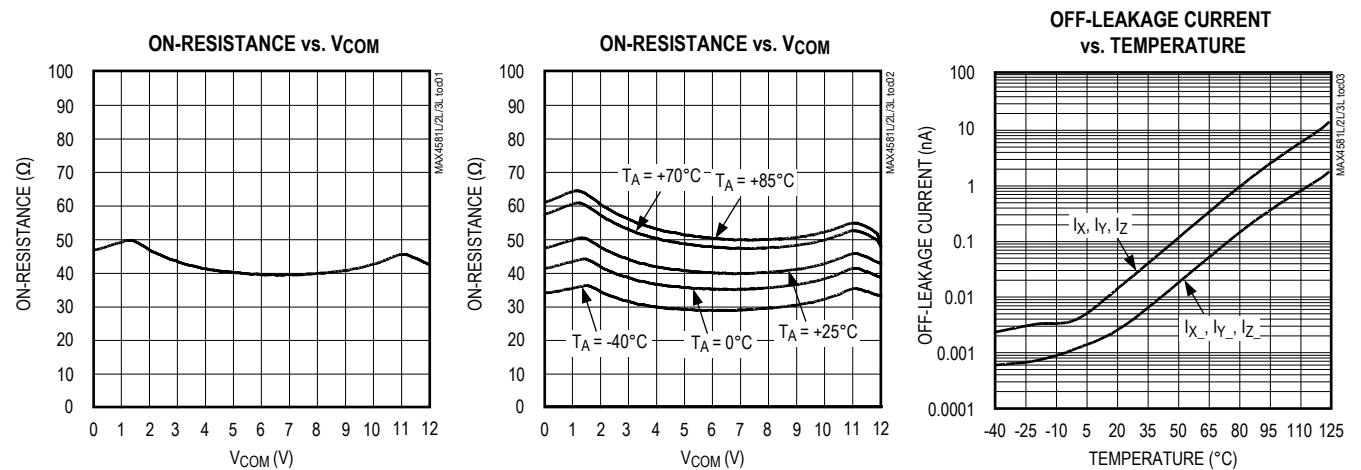

Typical Operating Characteristics (continued)

(VCC = 12V, VEN = GND, TA = +25°C, unless otherwise noted.)

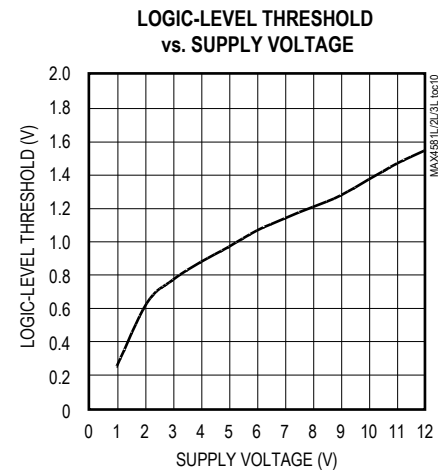
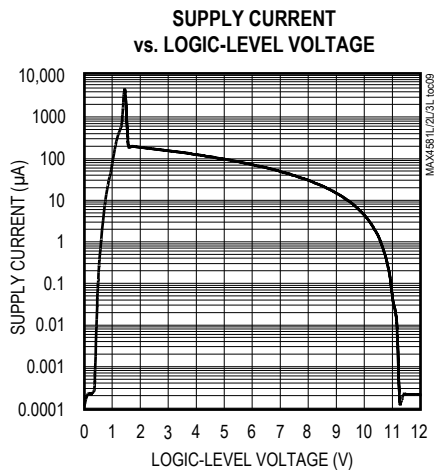
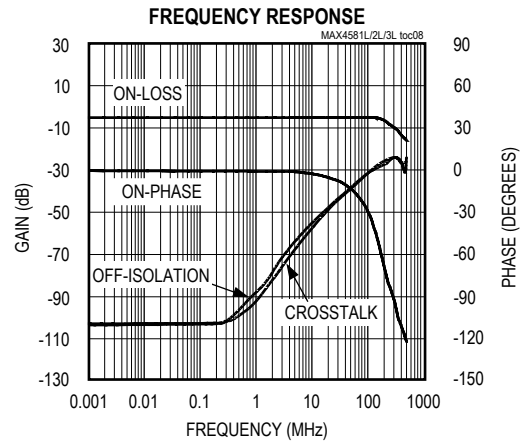
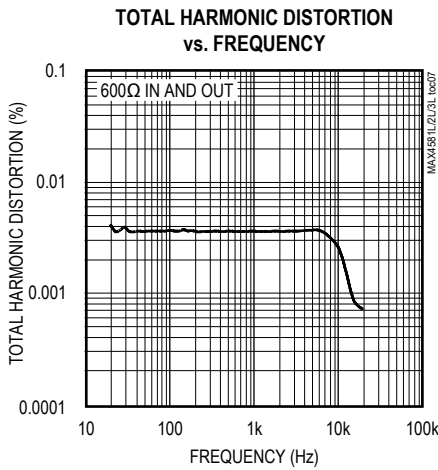
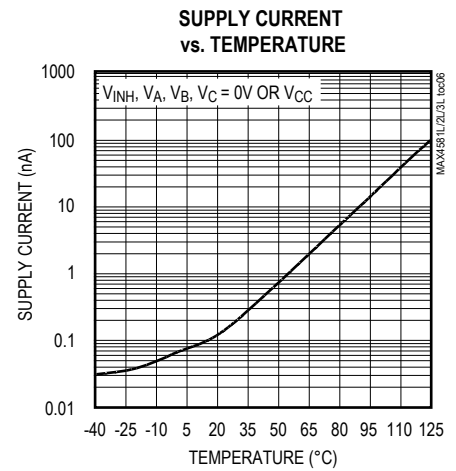
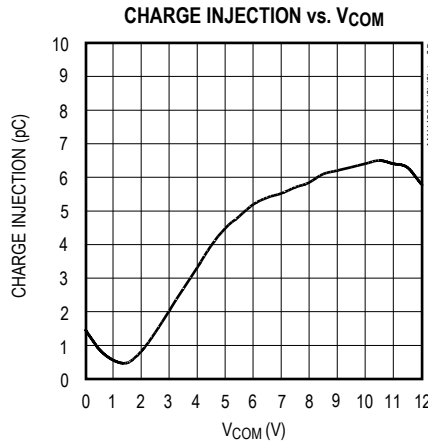
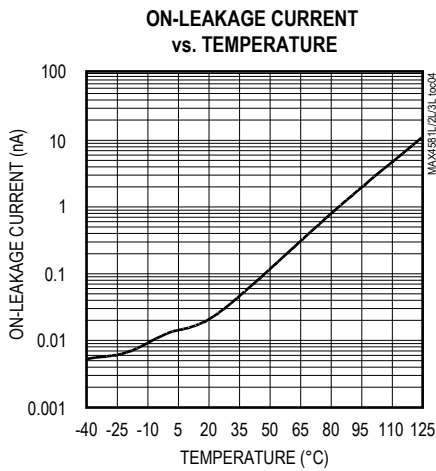

Pin Description

PIN						NAME	FUNCTION
MAX4581L		MAX4582L		MAX4583L			
SO/QSOP	QFN	SO/QSOP	QFN	SO/QSOP	QFN		
1, 2, 4, 5, 12–15	2, 3, 10–13, 15, 16	—	—	—	—	X0–X7	Analog Switch Inputs 0–7
3	1	13	11	14	12	X	Analog Switch X Output
6	4	6	4	6	4	Enable	Digital Enable Input. Drive enable low or connect to GND for normal operation.
7, 8	5, 6	7, 8	5, 6	7, 8	5, 6	GND	Ground. Connect to digital ground. (Analog signals have no ground reference; they are limited to V_{CC} .)
9	7	—	—	9	7	C	Digital Address C Input
10	8	9	7	10	8	B	Digital Address B Input
11	9	10	8	11	9	A	Digital Address A Input
16	14	16	14	16	14	VCC	Positive Analog and Digital Supply Voltage Input. Bypass with a 0.1 μ F capacitor to GND.
—	—	11, 12, 14, 15,	9, 10, 12, 13	—	—	X0–X3	Analog Switch X Inputs 0–3
—	—	1, 2, 4, 5	2, 3, 15, 16	—	—	Y0–Y3	Analog Switch Y Inputs 0–3
—	—	3	1	15	13	Y	Analog Switch Y Output
—	—	—	—	13	11	X1	Analog Switch X Normally Open Input
—	—	—	—	12	10	X0	Analog Switch X Normally Closed Input
—	—	—	—	1	15	Y1	Analog Switch Y Normally Open Input
—	—	—	—	2	16	Y0	Analog Switch Y Normally Closed Input
—	—	—	—	3	1	Z1	Analog Switch Z Normally Open Input
—	—	—	—	5	3	Z0	Analog Switch Z Normally Closed Input
—	—	—	—	4	2	Z	Analog Switch Z Output
—	EP	—	EP	—	EP	Exposed Pad	Bottom of QFN package only. Contains an exposed pad that must be connected externally to V_{CC} .

Note: Input and output pins are identical and interchangeable. Any may be considered an input or output; signals pass equally well in both directions.

Detailed Description

The MAX4581L/MAX4582L/MAX4583L are low-voltage, CMOS analog ICs that operate from a single supply of +2V to +12V. The MAX4581L is configured as an 8-channel multiplexer, the MAX4582L as two 4-channel multiplexers, and the MAX4583L as three single-pole/double-throw (SPDT) switches. These devices can handle rail-to-rail analog signals with only 2nA of off-leakage current at +25°C.

The MAX4581L/MAX4582L/MAX4583L are TTL/CMOS-logic compatible with 0.8V to 2.0V logic thresholds for all digital inputs when operating from a +12V supply.

Applications Information

Power-Supply Considerations

The MAX4581L/MAX4582L/MAX4583Ls' construction is typical of most CMOS analog switches. The supply input, V_{CC} , is used to power the internal CMOS switches and sets the limit of the analog voltage on any switch. Reverse ESD protection diodes are internally connected between each analog signal pin and both V_{CC} and GND. If any analog signal exceeds V_{CC} or goes below GND, one of these diodes conducts. During normal operation, these reverse-biased ESD diodes leak, causing the only current drawn from V_{CC} or GND. Virtually all the analog leakage current comes from the ESD diodes. Although the ESD diodes on a given signal pin are identical, and therefore fairly well balanced, they are reverse biased differently by either V_{CC} or GND and the analog signal.

This means that leakage varies as the analog signal varies. The difference in the two diodes' leakage to V_{CC} and GND constitutes the analog signal-path leakage current. Because there is no connection between the analog signal paths and GND, all analog leakage current flows between each pin and one of the supply terminals, not to the other switch terminal. Because of this, both sides of a given switch can show leakage currents of either the same or opposite polarity.

V_{CC} and GND power the internal logic and logic-level translators, and set both the input and output logic limits. The logic-level translators convert the logic levels into switched V_{CC} and GND signals to drive the gates of the analog switches. This drive signal is the only connection between the logic supplies (and signals) and the analog supplies. The logic-level thresholds are TTL/CMOS compatible when V_{CC} is +12V.

Overvoltage Protection

Proper power-supply sequencing is recommended for all CMOS devices. Do not exceed the absolute maximum ratings because stresses beyond the listed ratings can cause permanent damage to the devices. Always sequence V_{CC} first, followed by the logic inputs and analog signals.

Pin Nomenclature

The MAX4581L/MAX4582L/MAX4583L are pin compatible with the industry-standard 74HC4051/74HC4052/74HC4053 and the MAX4051/MAX4052/MAX4053.

Table 1. Truth Table/Switch Programming

ENABLE INPUT	SELECT INPUTS			ON SWITCHES		
	C*	B	A	MAX4581L	MAX4582L	MAX4583L
H	X	X	X	All switches open	All switches open	All switches open
L	L	L	L	X-X0	X-X0, Y-Y0	X-X0, Y-Y0, Z-Z0
L	L	L	H	X-X1	X-X1, Y-Y1	X-X1, Y-Y0, Z-Z0
L	L	H	L	X-X2	X-X2, Y-Y2	X-X0, Y-Y1, Z-Z0
L	L	H	H	X-X3	X-X3, Y-Y3	X-X1, Y-Y1, Z-Z0
L	H	L	L	X-X4	X-X0, Y-Y0	X-X0, Y-Y0, Z-Z1
L	H	L	H	X-X5	X-X1, Y-Y1	X-X1, Y-Y0, Z-Z1
L	H	H	L	X-X6	X-X2, Y-Y2	X-X0, Y-Y1, Z-Z1
L	H	H	H	X-X7	X-X3, Y-Y3	X-X1, Y-Y1, Z-Z1

X = Don't care.

*C not present on MAX4582L.

Note: Input and output pins are identical and interchangeable. Either may be considered an input or output; signals pass equally well in either direction.

Test Circuits/Timing Diagrams

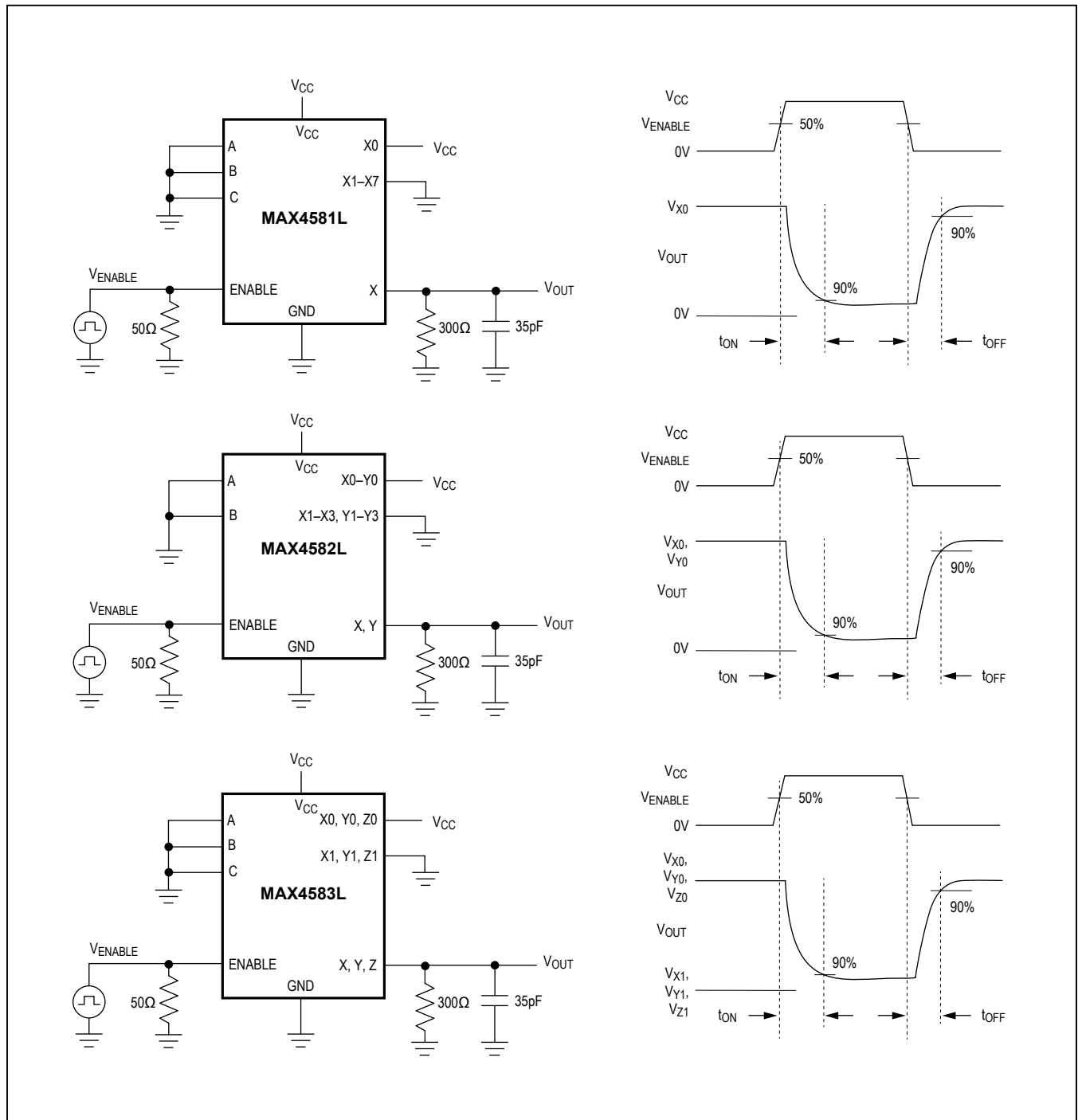

Figure 1. Enable Switching Times

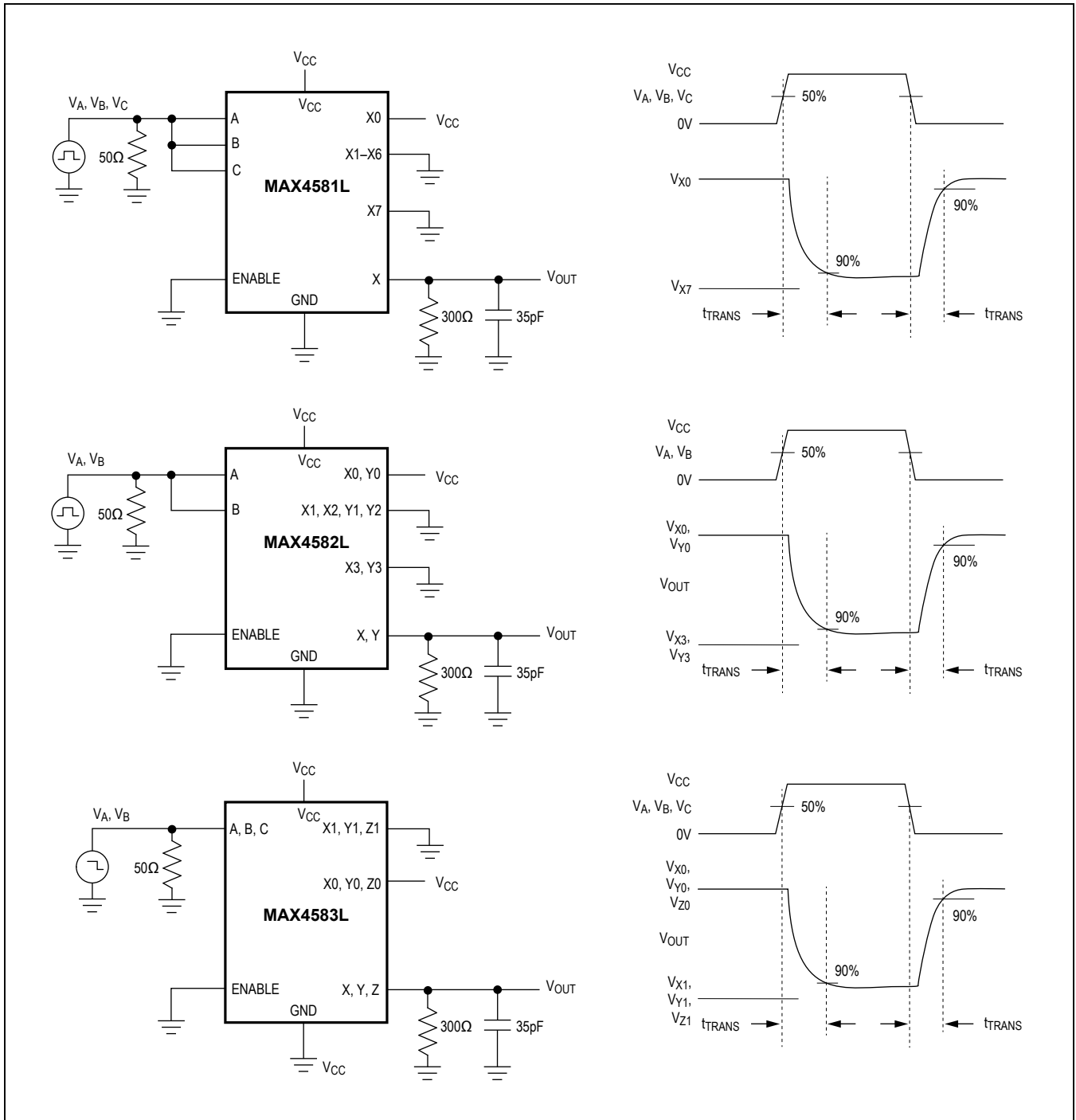

Figure 2. Address Transition Time

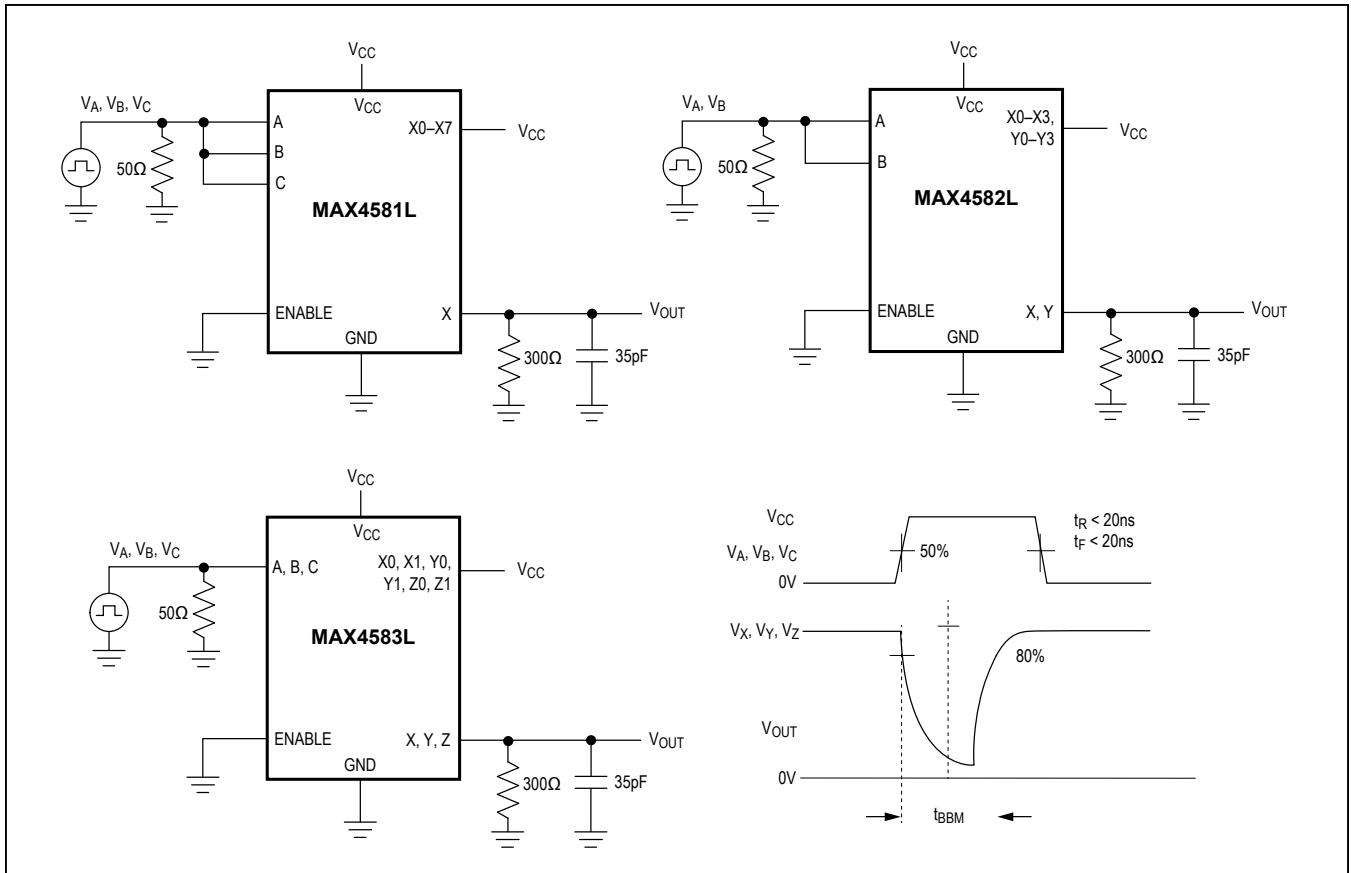

Figure 3. Break-Before-Make Interval

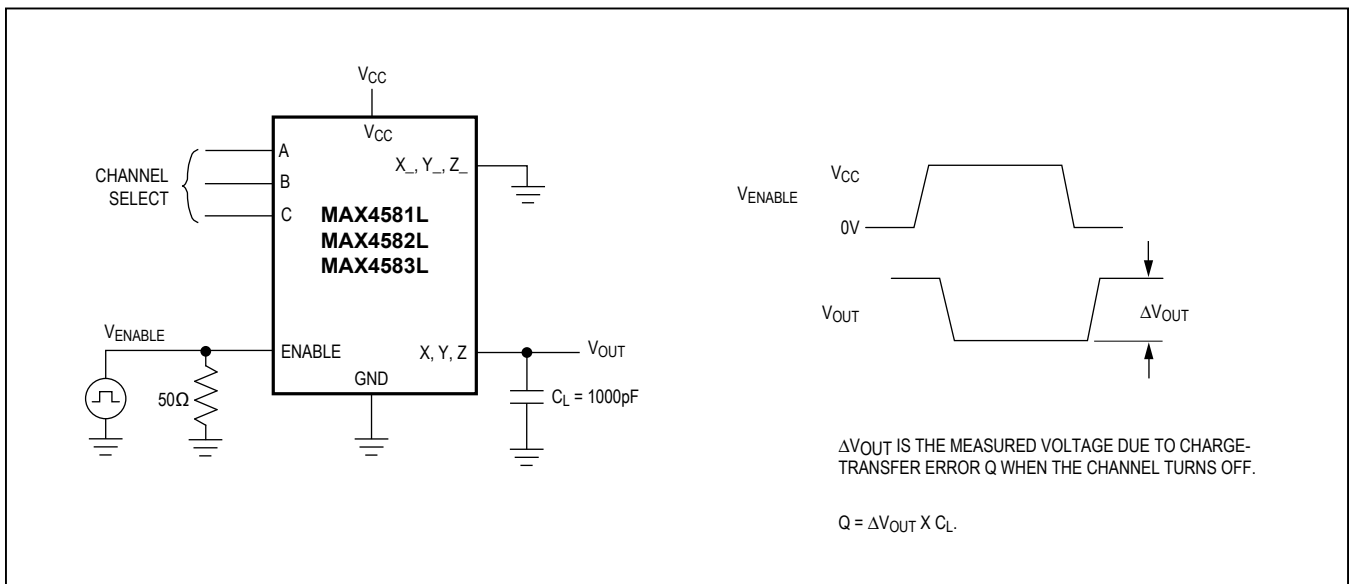

Figure 4. Charge Injection

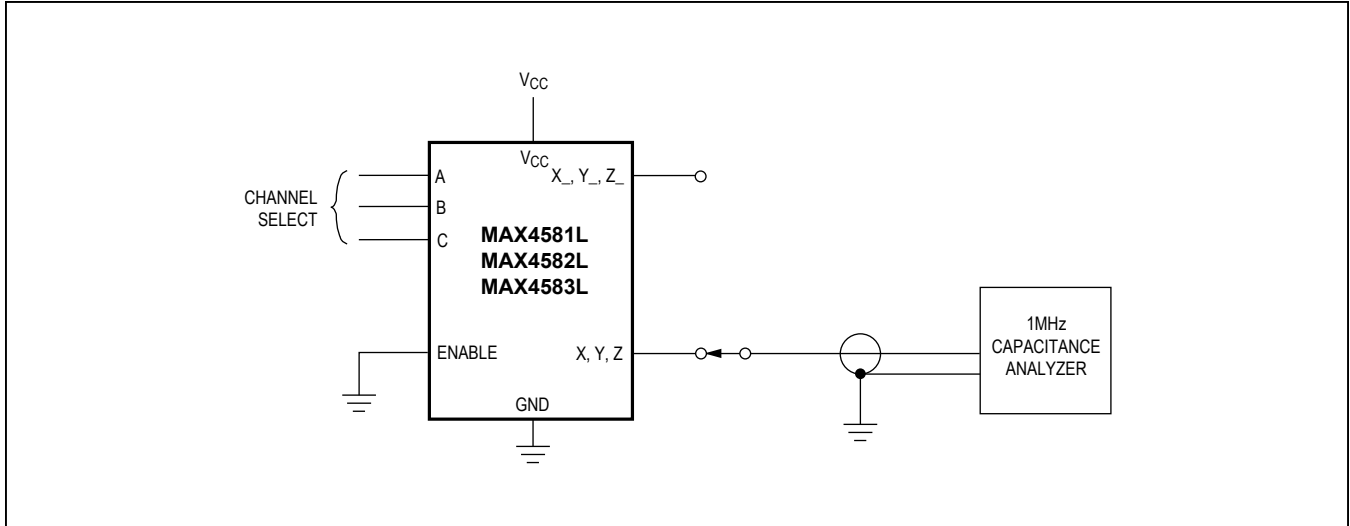

Figure 5. NO/COM Capacitance

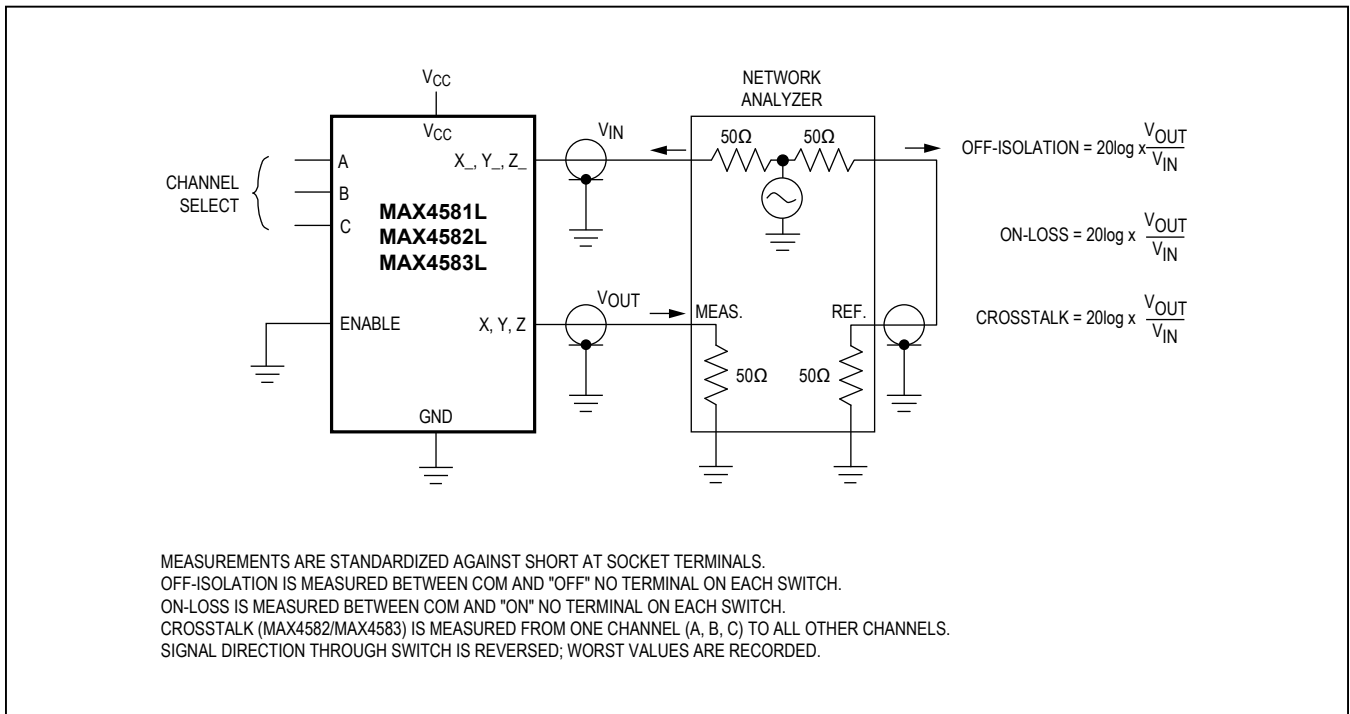
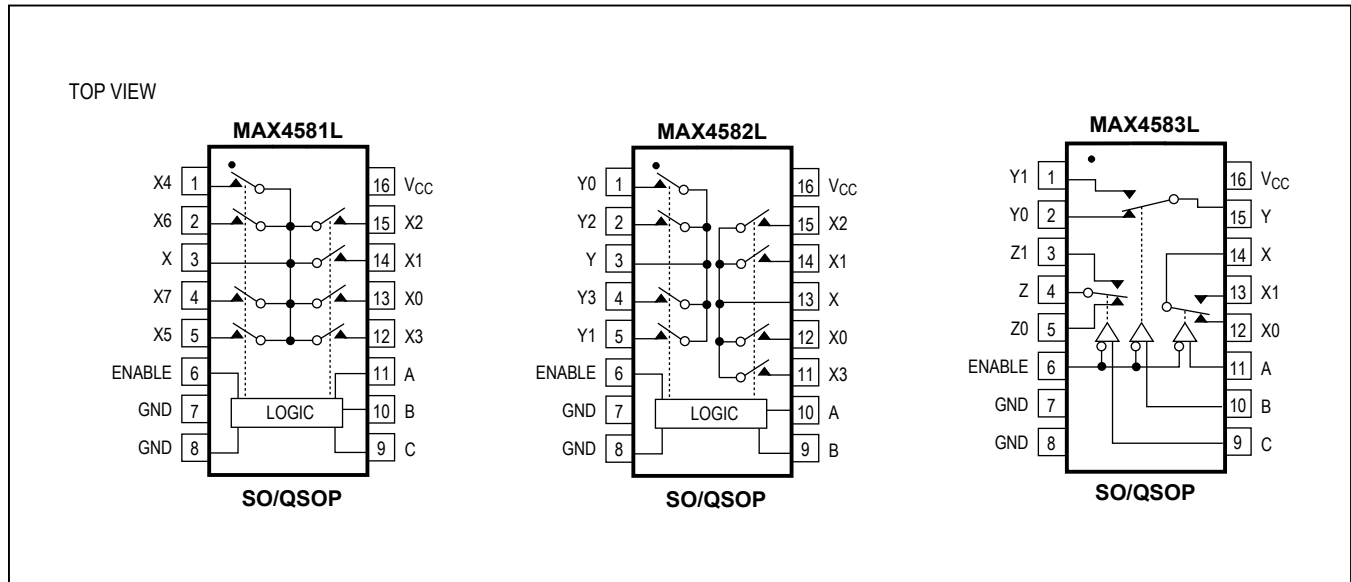

Figure 6. Off-Isolation, On-Loss, and Crosstalk

Pin Configurations/Functional Diagrams (continued)



Ordering Information (continued)

PART	TEMP RANGE	PIN-PACKAGE
MAX4582LESE	-40°C to +85°C	16 Narrow SO
MAX4582LEEE	-40°C to +85°C	16 QSOP
MAX4582LETE	-40°C to +85°C	16 TQFN-EP* (4mm x 4mm)
MAX4583LESE	-40°C to +85°C	16 Narrow SO
MAX4583LEEE	-40°C to +85°C	16 QSOP
MAX4583LETE	-40°C to +85°C	16 TQFN-EP* (4mm x 4mm)

*EP = Exposed pad.

Chip Information

TRANSISTOR COUNT: 219

PROCESS: CMOS

Package Information (continued)

For the latest package outline information and land patterns (footprints), go to www.maximintegrated.com/packages. Note that a "+", "#", or "-" in the package code indicates RoHS status only. Package drawings may show a different suffix character, but the drawing pertains to the package regardless of RoHS status.

PACKAGE TYPE	PACKAGE CODE	DOCUMENT NO.	LAND PATTERN NO.
16 Narrow SO	S16-3	21-0041	Refer to Application Note 1891
16 QSOP	E16-4	21-0055	
16 TQFN-EP	T1644-4	21-0139	

Revision History

REVISION NUMBER	REVISION DATE	DESCRIPTION	PAGES CHANGED
0	5/07	Initial release	—
1	6/07	Unknown	1, 6, 12, 16
2	5/14	Removed automotive reference under <i>Applications</i> section	1

For pricing, delivery, and ordering information, please contact Maxim Direct at 1-888-629-4642, or visit Maxim Integrated's website at www.maximintegrated.com.

Maxim Integrated cannot assume responsibility for use of any circuitry other than circuitry entirely embodied in a Maxim Integrated product. No circuit patent licenses are implied. Maxim Integrated reserves the right to change the circuitry and specifications without notice at any time. The parametric values (min and max limits) shown in the Electrical Characteristics table are guaranteed. Other parametric values quoted in this data sheet are provided for guidance.