

Introduction

Bridgelux OLM™ Series of outdoor lighting modules introduce a simple and easy way to develop innovative and leading LED luminaires. The highly adaptable platform allows for rapid product development and portfolio expansion. Proprietary optics and environmental protection enable cost and performance advantages within the exterior and industrial market segments.

Luminaires used in outdoor lighting require long life combined with stable and consistent performance over the life of the product. The OLM subsystems are designed to deliver high quality, energy efficient lighting for commercial, industrial, and exterior applications. Designed around the unique and innovative Bridgelux LED arrays, the modules deliver targeted lumen output levels to replace incumbent products that utilize high pressure sodium (HPS) and metal halide technologies.

Designed for integration, the lighting subsystems mechanically attach with four screws. Soldering, glues, and epoxies are removed from the assembly process and replaced with a robust electrical connection. The integration of optics, environmental protection and the LED source are unparalleled in the LED lighting industry.

The OLM subsystems leverages the Bridgelux Vero™ Series, the latest generation of Bridgelux LED arrays, which deliver high performance, compact and cost-effective solid-state lighting solutions to serve the general lighting market. These products combine higher efficiency, lifetime, and reliability benefits of LEDs with the light output levels of many conventional light sources.

Features

- Typical efficacy of 90 lm/W to 118 lm/W
- Typical lumen output ranges from 2100 to 4500 lumens
- Broad range of CCT options from 4000K to 5600K
- CRI options include; minimum 70 and 80
- Reliable operation for outdoor use
- Asymmetric and symmetric lighting patterns
- IP66 rated for outdoor use
- High level component integration
- Ease of assembly

Benefits

- Designed to replace HPS bulbs in application
- Optimized for color and efficacy
- High quality true color reproduction
- Long lifetime with a strong return on investment
- Uniform lighting patterns designed for targeted applications
- Improved thermal management
- Simplified robust luminaire design and assembly
- Improved inventory management and quality control



Contents

Product Feature Map	3
Product Nomenclature.....	3
Product Selection Guide	4
Absolute Maximum Ratings	5
Typical Relative Luminous Flux Characteristics.....	6
Optical Characteristics	8
Photometric Performance (Optical Code: A01A).....	8
Photometric Performance (Optical Code: A06A).....	7
Mechanical Dimensions	8
Design Resources	9
Precautions	9

Product Feature Map

OLM is the first product line in the exciting new Bridgelux series of next generation solid-state lighting subsystems. In addition to delivering the performance and light quality required for many exterior and industrial lighting applications, OLM incorporates several features to simplify the design integration and manufacturing process, accelerate time to market and reduce system costs. Please consult the Bridgelux OLM Brochure for more information on the OLM products.

Figure 1: Product Feature Map



Product Nomenclature

The part number designation for the Bridgelux OLM Series is explained as follows:

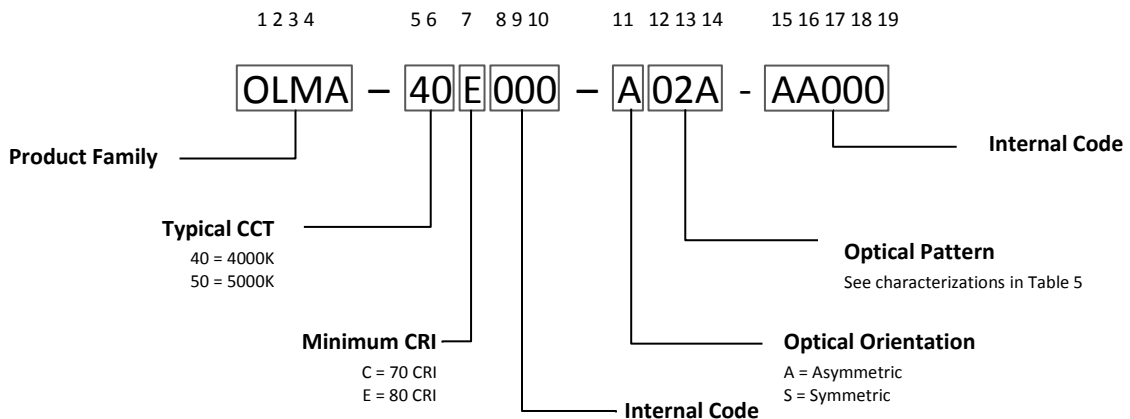

Product Selection Guide

The following product configurations are available:

Table 1: Product Selection Guide

Part Number	Nominal CCT (K)	CRI	Drive Current (mA)	Typical Pulsed Flux ^[1] Tc = 25°C (lm)	Typical Flux ^[2,3,4] Tc = 70°C (lm)	Typical Vf ^[5] (V)	Typical Power (W)	Typical Pulsed Efficacy Tc = 25°C (lm/W)	Typical Efficacy Tc = 70°C (lm/W)
OLMA-50C000-xxxx-xx000	5000	70	350	2,438	2,144	53	18.6	131.1	115
			500	3,335	2,932	55.3	27.6	120.8	106
			700	4,429	3,894	58	40.6	109.1	96
OLMA-40E000-xxxx-xx000	4000	80	350	2,284	2,022	53	18.6	122.8	109
			500	3,123	2,765	55.3	27.6	113.2	100
			700	4,139	3,665	58	40.6	102.0	90
OLMA-40C000-xxxx-xx000	4000	70	350	2,389	2,115	53	18.6	128.4	114
			500	3,266	2,892	55.3	27.6	118.3	105
			700	4,329	3,833	58	40.6	106.6	94
OLMA-56C000-xxxx-xx000	5600	70	350	2,498	2,196	53	18.6	134.3	118
			500	3,417	3,005	55.3	27.6	123.8	109
			700	4,535	3,987	58	40.6	111.7	98

Notes for Tables 1:

1. Tested in pulsed conditions at the 350mA drive current, Tc = 25°C. Pulse width is 10 ms.
2. Typical performance when driven under DC (direct current) at test current with LED array case temperature maintained at 70°C, mounted to heat sink with thermal interface material. Based on Bridgelux test setup, values may vary depending on the thermal design of the luminaire and/or the exposed environment to which the product is subjected.
3. Bridgelux maintains a ± 10% tolerance on flux values.
4. Typical stabilized DC performance values are provided as reference only and are not a guarantee of performance.
5. Bridgelux maintains a tester tolerance of ± 0.20 V on forward voltage measurements.

Table 2: Electrical Characteristics and Driver Selection Voltages

Drive Current (mA) ^[1]	Forward Voltage Pulsed, Tc = 25°C (V) ^[2]			Typical Coefficient of Forward Voltage $\Delta V_f / \Delta T_c$ (mV/°C)	Typical Thermal Resistance Array case to Module case (C/W)
	Minimum	Typical	Maximum		
350	49	53	57	-28	0.41
700	53	58	62.4	-28	0.47

Notes for Table 2:

1. Tested in pulsed conditions at the 350mA drive current, Tc = 25°C. Pulse width is 10 ms.
2. Bridgelux maintains a tester tolerance of ± 0.20 V on forward voltage measurements.

Absolute Maximum Ratings

Table 3: Maximum Drive Current and Reverse Voltage Ratings

Part Number	Maximum DC Forward Current (mA) ^[3]	Maximum Peak Pulsed Current (mA) ^[1]	Maximum Reverse Voltage (Vr) ^[2]
OLMA-xxx000-xxxx-xx000	700	1500	-90

Notes for Table 3:

1. Bridgelux recommends a maximum duty cycle of 10% when operating LED Arrays at the maximum peak pulsed current specified. Maximum peak pulsed currents indicate values where the LED array can be driven without catastrophic failures.
2. Light emitting diodes are not designed to be driven in reverse voltage and will not produce light under this condition. Maximum rating provided for reference only.
3. Lumen maintenance (L70) and lifetime predictions are valid for drive current and case temperature conditions used for LM-80 testing as included in the applicable LM-80 test report for the Bridgelux Vero Series of COB arrays used in the OLM Series subsystems. Contact your Bridgelux sales representatives for LM-80 report.

Table 4: Maximum Ratings

Parameter	Maximum Rating
LED Junction Temperature	150
Storage Temperature	-40°C to +55°C
Maximum Ambient Temperature	55°C
Operating Module Case Temperature	70°C

Typical Relative Luminous Flux Characteristics

Typical performance at any drive current and temperature can be derived from the characteristics shown in Figures 1 and 2.

Figure 1: Relative Luminous Flux vs. Drive Current

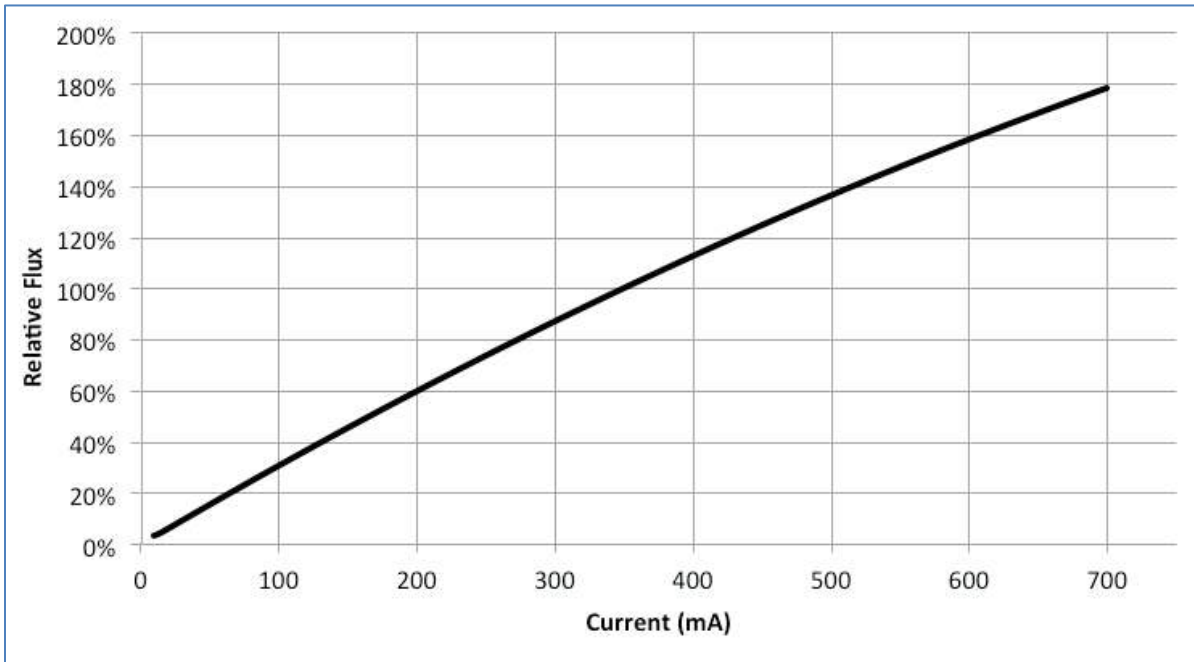

Figure 2: Relative Luminous Flux vs. Module Case Temperature

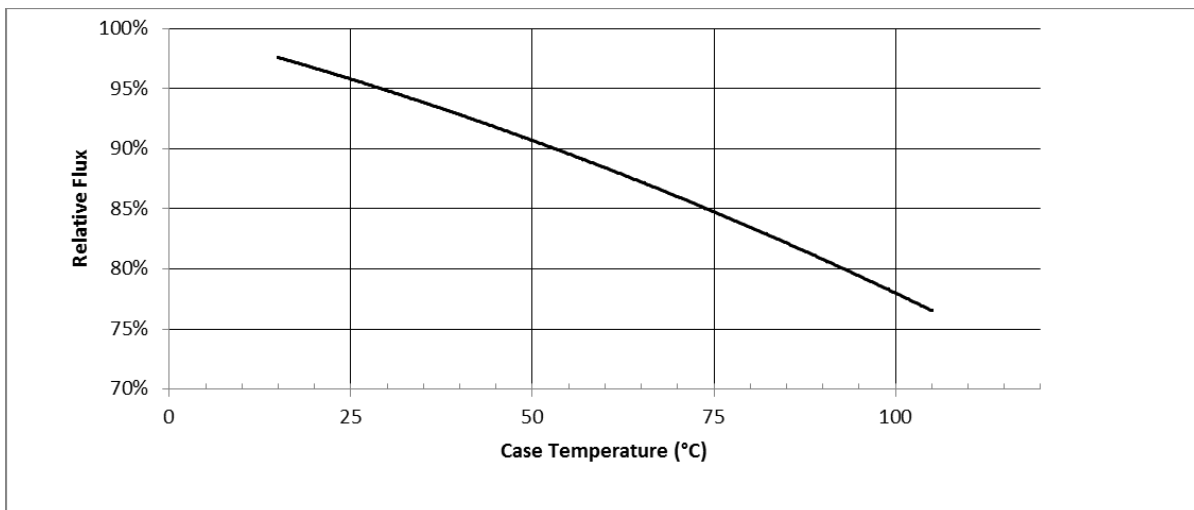

Figure 3: Typical DC ccy Shift vs. Case Temperature

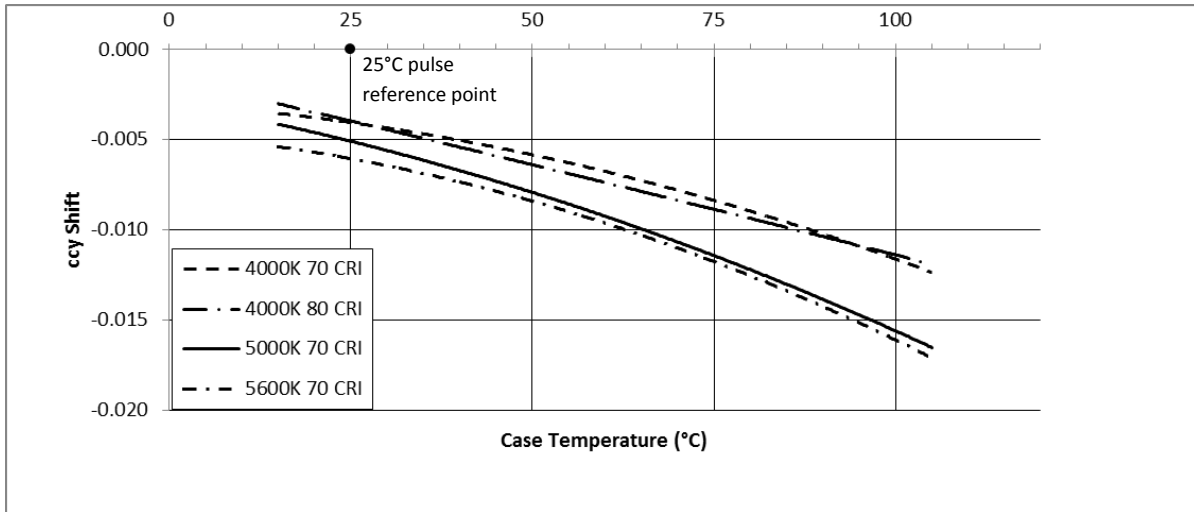
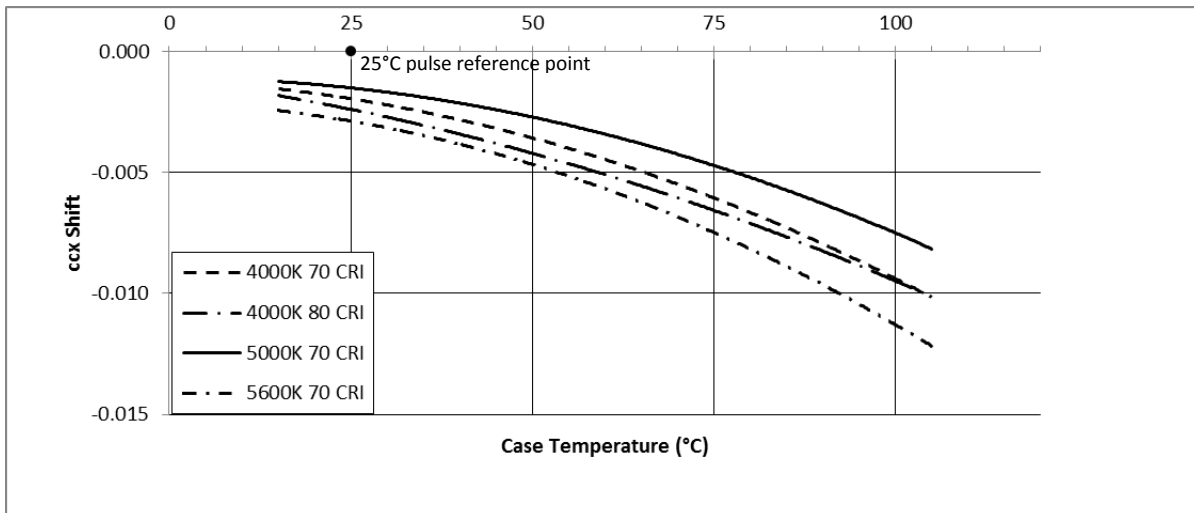

Figure 4: Typical DC ccx Shift vs. Case Temperature



Optical Characteristics

Table 5: Optical Pattern Descriptions

Optical Code	Description	IES Classification	NEMA Classification	EN 13-201 Guidance
A01A	Asymmetric; Narrow, Short Width	Type II, Med	7H x 7V	ME2 – ME4
A06A	Asymmetric; Medium, Short Width	Type III, Short	7H x 7V	ME2 – ME4

Photometric Performance (Optical Code: A01A)

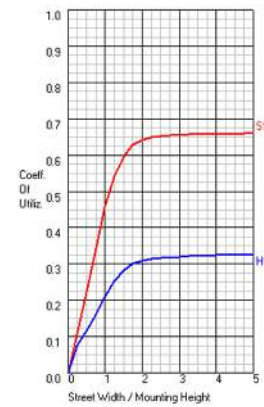
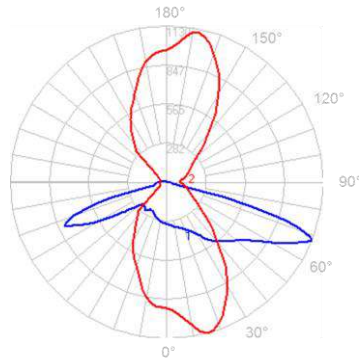
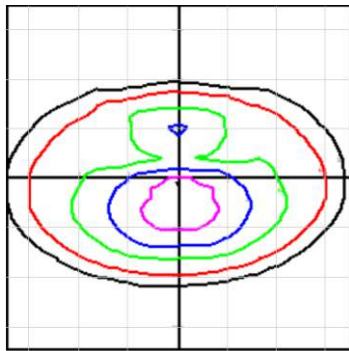

Photometric Performance (Optical Code: A06A)

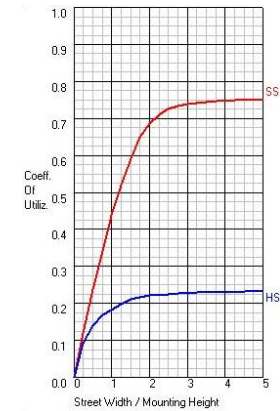
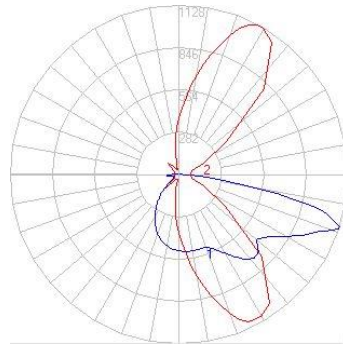
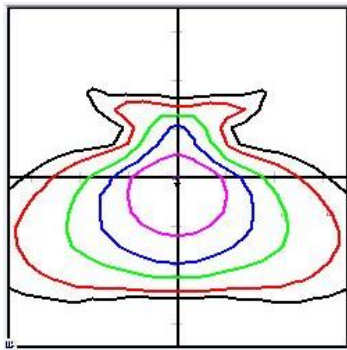

Mechanical Dimensions

Figure 5: Mechanical Dimensions

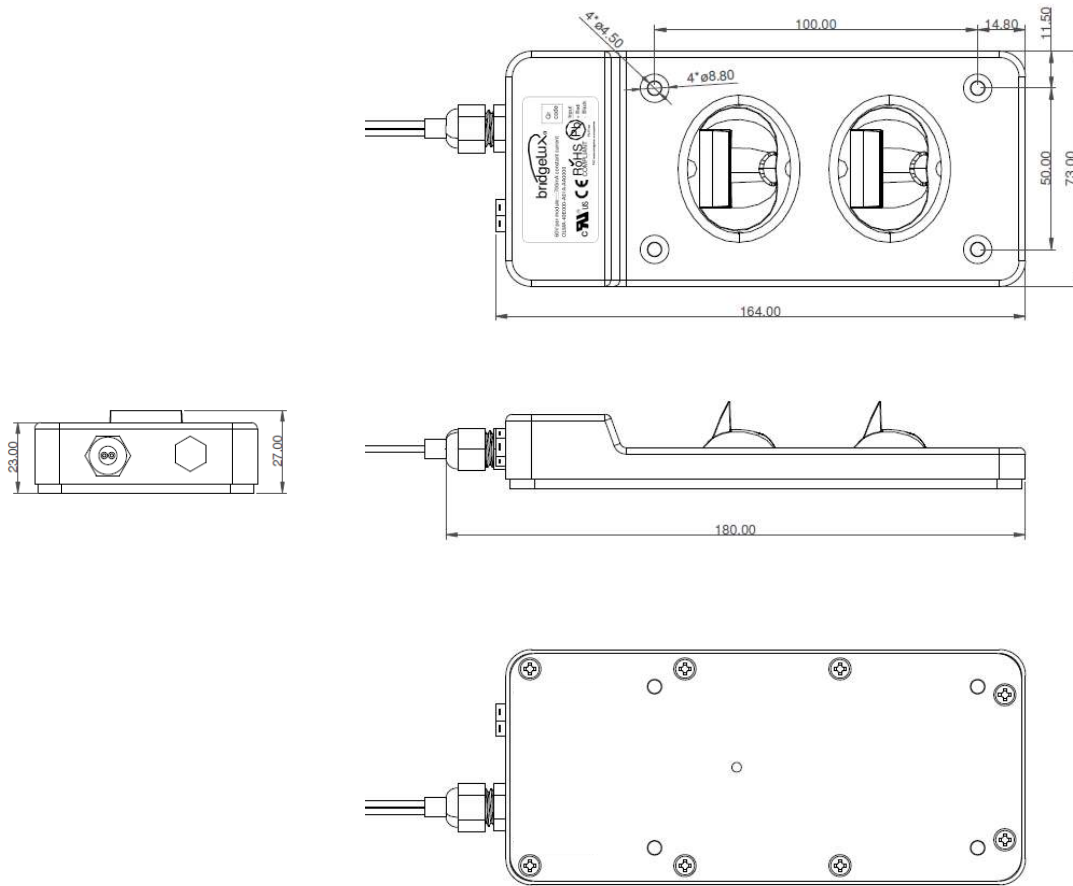

Notes for Figure 5:

1. Mounting holes (4X) accommodate M4 or #8 screws.
2. Screws with flat shoulders (pan, dome, button, round, truss, mushroom) provide optimal torque control. Do NOT use flat, countersink, or raised head screws.
3. Drawing dimensions are in millimeters.
4. Unless otherwise specified, tolerances are $\pm 1.00\text{mm}$.
5. Refer to Application Notes AN30 and AN61 for product handling, mounting and heat sink recommendations.

Design Resources

Design Guide

Bridgelux has developed a comprehensive design guide and design resources to assist customers in successfully designing with the OLM modules. For a list of resources under development, visit www.bridgelux.com.

Optical Files

Far field optical files are available in .IES and .LDT format.

3D CAD Models

Three dimensional CAD models depicting the product outline are available in both SAT and STEP formats. Please contact your Bridgelux sales representative for assistance.

Precautions

CAUTION: CONTACT WITH OPTICAL AREA

The OLM is manufactured with molded polycarbonate lenses. The lens is extremely durable, but not indestructible. Contact may cause damage to the module.

CAUTION: CHEMICAL EXPOSURE HAZARD

Exposure to some chemicals commonly used in luminaire manufacturing and assembly can cause damage to the LED array. Please consult the Bridgelux Design Guide for additional information.

CAUTION: EYE SAFETY

Eye safety classification for the use of Bridgelux Vero LED arrays and the OLM sub-system is in accordance with IEC specification EN62471: Photobiological Safety of Lamps and Lamp Systems. Vero LED arrays are classified as Risk Group 1 (Low Risk) when operated at or below the maximum DC forward current (2x the nominal rated test current as is defined in Table 3 of this data sheet). Please use appropriate precautions. It is important that employees working with LEDs are trained to use them safely.

CAUTION: RISK OF BURN

Do not touch the module lens area during operation. Allow the module to cool for a sufficient period of time before handling.

Minor Product Change Policy

The rigorous qualification testing on products offered by Bridgelux provides performance assurance. Slight cosmetic changes that do not affect form, fit, or function may occur as Bridgelux continues product optimization.

About Bridgelux

At Bridgelux, we help companies, industries and people experience the power and possibility of light. Since 2002, we've designed LED solutions that are high performing, energy efficient, cost effective and easy to integrate. Our focus is on light's impact on human behavior, delivering products that create better environments, experiences and returns—both experiential and financial. And our patented technology drives new platforms for commercial and industrial luminaires.

For more information about the company, please visit

bridgelux.com

twitter.com/Bridgelux

facebook.com/Bridgelux

WeChat ID: BridgeluxInChina