

**761KS, 767KS, AND S761KS SERIES SEALED PLUGS**

761KS -  $\phi$ 0.100 (2.5MM) REF  
 767KS -  $\phi$ 0.084 (2.1MM) REF  
 S761KS -  $\phi$ 0.080 (2.0MM) REF

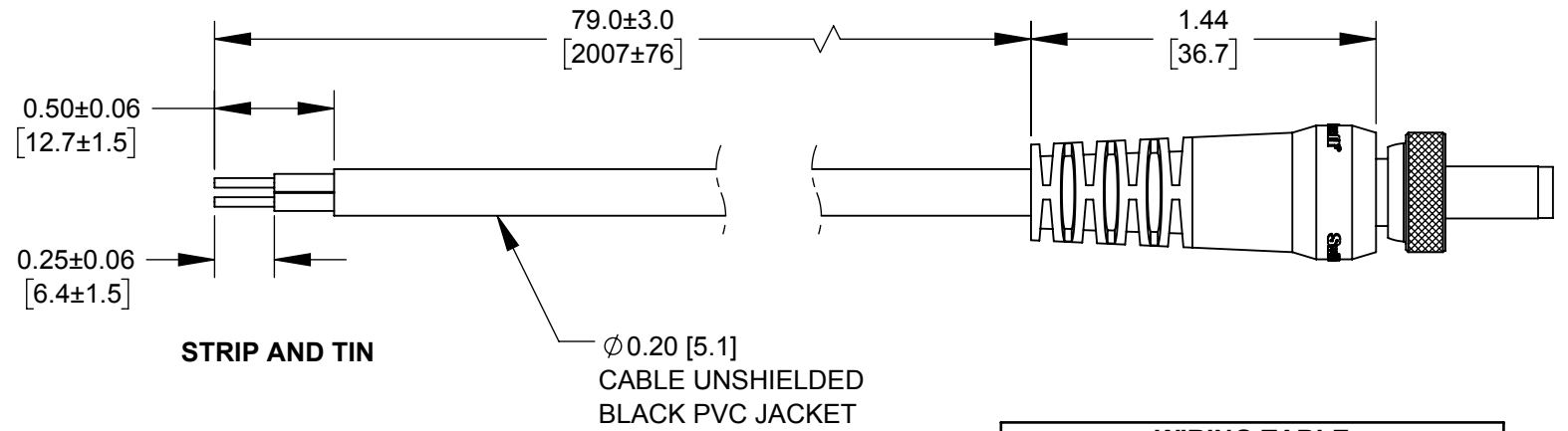

**STRIP AND TIN**

WIRING TABLE	
POWER PLUG	WIRE COLOR
TIP	RED
SLEEVE	BLACK

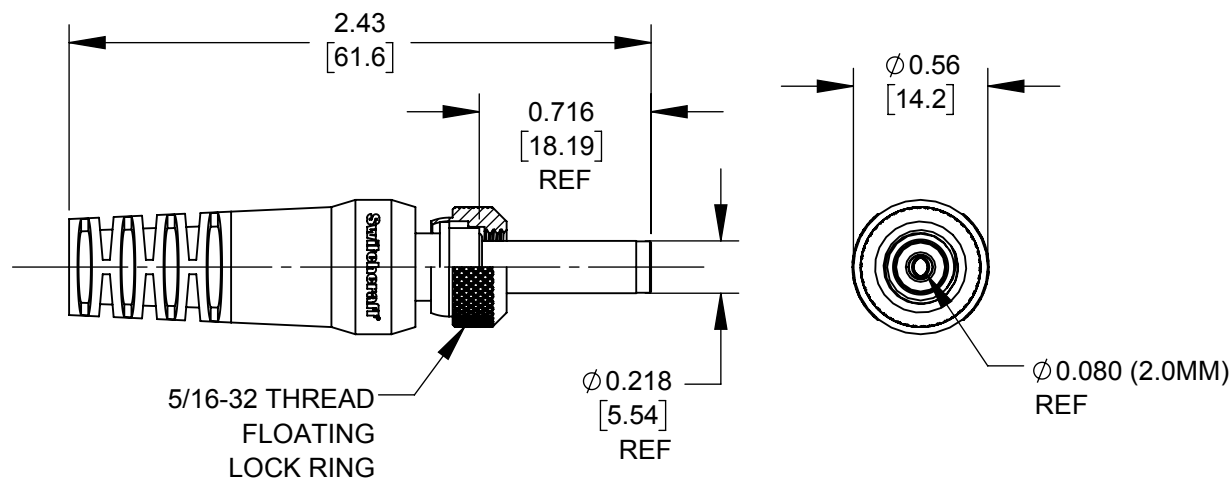

**S10KS SERIES SEALED HI-AMP PLUG**

$\phi$ 0.080 (2.0MM) REF

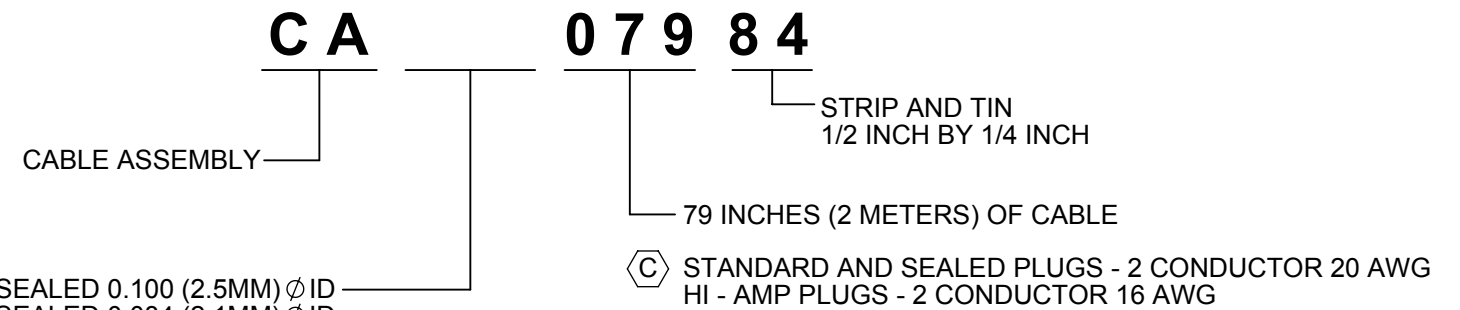

- 761KS** - SEALED 0.100 (2.5MM)  $\phi$  ID
- 767KS** - SEALED 0.084 (2.1MM)  $\phi$  ID
- S761KS** - SEALED 0.080 (2.0MM)  $\phi$  ID
- S10KS** - HI AMP - SEALED 0.080(2.0MM)  $\phi$  ID
- S10** - HI AMP NON-SEALED - 0.080(2.0MM)  $\phi$  ID NON-LOCKING
- 760** - DC POWER PLUG 0.100 (2.5MM)  $\phi$  ID NON-LOCKING
- 762** - DC POWER PLUG 0.084 (2.1MM)  $\phi$  ID NON-LOCKING
- S760** - DC POWER PLUG 0.080 (2.0MM)  $\phi$  ID NON-LOCKING
- 760K** - DC POWER PLUG 0.100 (2.5MM)  $\phi$  ID LOCKING
- 761K** - DC POWER PLUG 0.100 (2.5MM)  $\phi$  ID LOCKING
- 762K** - DC POWER PLUG 0.084 (2.1MM)  $\phi$  ID LOCKING
- 767K** - DC POWER PLUG 0.084 (2.1MM)  $\phi$  ID LOCKING
- S760K** - DC POWER PLUG 0.080 (2.0MM)  $\phi$  ID LOCKING
- S761K** - DC POWER PLUG 0.080 (2.0MM)  $\phi$  ID LOCKING

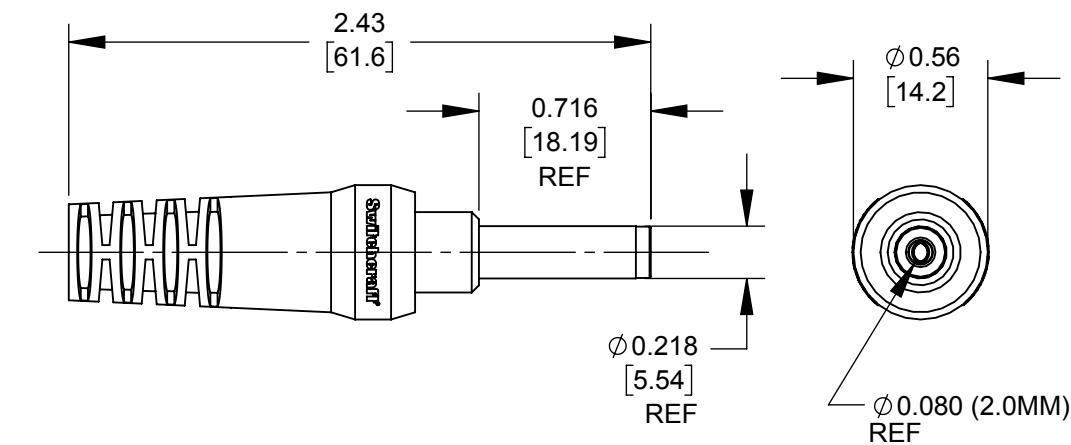

**S10 SERIES NON-SEALED NON-LOCKING HI-AMP PLUG**

REV	ECO NUMBER	DATE	BY	APVD
C	27930	08-17-17	PC	TJK
B	27615	11-30-15	TO	TJK
A	27477	4/2/15	TJK	TJK

UNLESS OTHERWISE SPECIFIED  
 1. ALL DIMENSIONS IN INCHES [mm]  
 - TWO PLACE DECIMALS  $\pm$ 0.02 [0.5]  
 - THREE PLACE DECIMALS  $\pm$ 0.005 [0.13]

DO NOT SCALE DRAWING

THIS DRAWING DESCRIBES A DESIGN CONSIDERED PROPRIETARY IN NATURE, DEVELOPED AND MANUFACTURED BY SWITCHCRAFT INC. AND IS RELEASED ON A CONFIDENTIAL BASIS FOR IDENTIFICATION PURPOSES ONLY.					
SIZE	WIDTH	MULT	LBS/M	TEMPER	
FINISH SPEC No.			MATERIAL SPEC No.		
FIRST USED ON			SCALE 1.25:1		
DATE DRAWN	BY	CHKD	APVD	Switchcraft®	
3/19/15	AB	AB	TJK		
NAME CABLE ASSEMBLY - MOLDED STRAIGHT POWER PLUGS, RoHS				PART No. CA__07984	
SHEET 1 OF 2				REV C	

**CUSTOMER DRAWING**

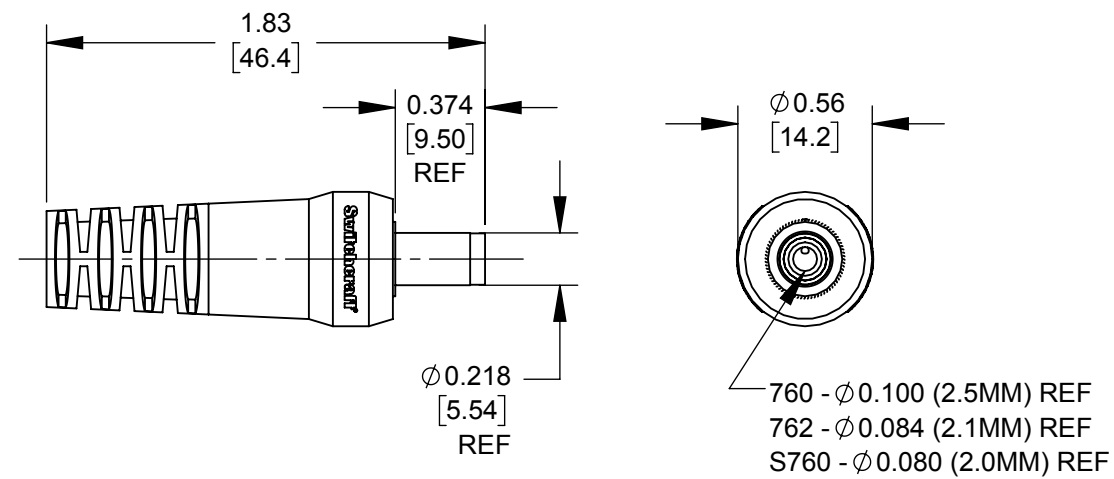

**C** 760, 762, AND S760 SERIES  
NON-LOCKING POWER PLUGS

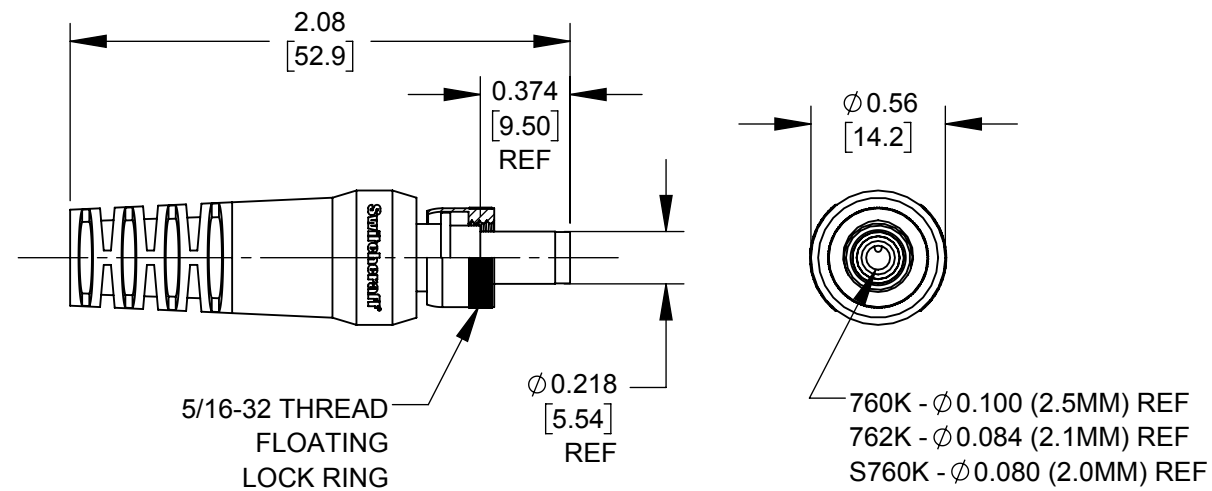

**C** 760K, 762K, AND S760K SERIES  
LOCKING POWER PLUG

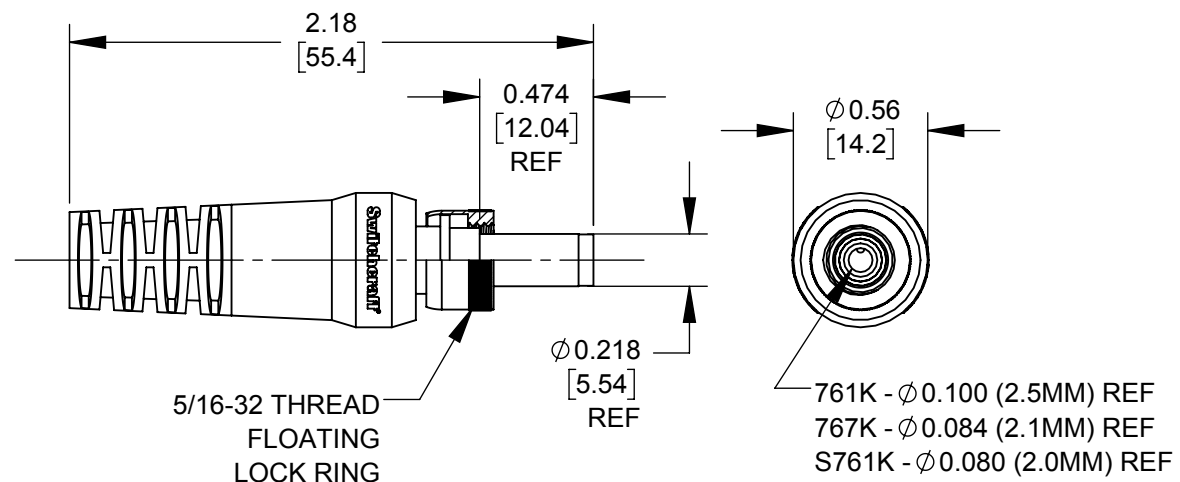

**C** 761K, 767K, AND S761K SERIES  
LOCKING POWER PLUGS

**CUSTOMER DRAWING**

SCALE 1.25:1	<b>Switchcraft</b> <sup>®</sup>	
DATE DRAWN 08/02/17		
DRAWN BY ALM	PART No. CA 07984	REV C