

THIS PRODUCT MANUFACTURED WITH LEAD-FREE PROCESSING

DESIGNED & DIMENSIONED IN MILLIMETERS [INCHES]

SMA-J-C-X-ST-SR3

GENDER
-J: JACK

TYPE
-C: CABLE

TERMINATION
-SR3: SEALED REVERSE POLARITY BULKHEAD (MH081)

ORIENTATION
-ST: STRAIGHT

PLATING SPECIFICATION
-H: 30µ" GOLD CENTER CONTACT, 3µ" GOLD OUTER CONTACT (SEE TABLE 1)

DO NOT SCALE FROM THIS PRINT

TABLE 1		
ITEM	COMPONENT	-H
1	HEX NUT	SMA-NUT-001-F
2	LOCK WASHER	SMA-LWAS-001-F
3	GASKET	SMA-GKT-002
4	SUB ASSEMBLY	SUB-SMA-J-C-F-ST-SB3
5	PIN	SMA-PIN-006-H
6	INSULATOR	SMA-INS-016
7	CABLE BODY	SMA-J-C-F-ST-BH3-CBDY

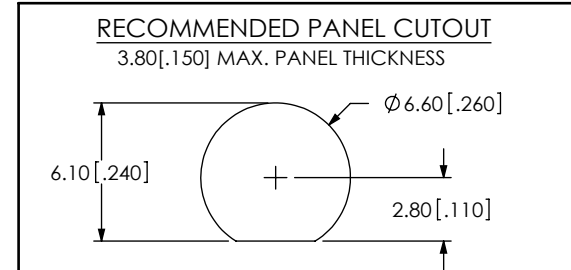
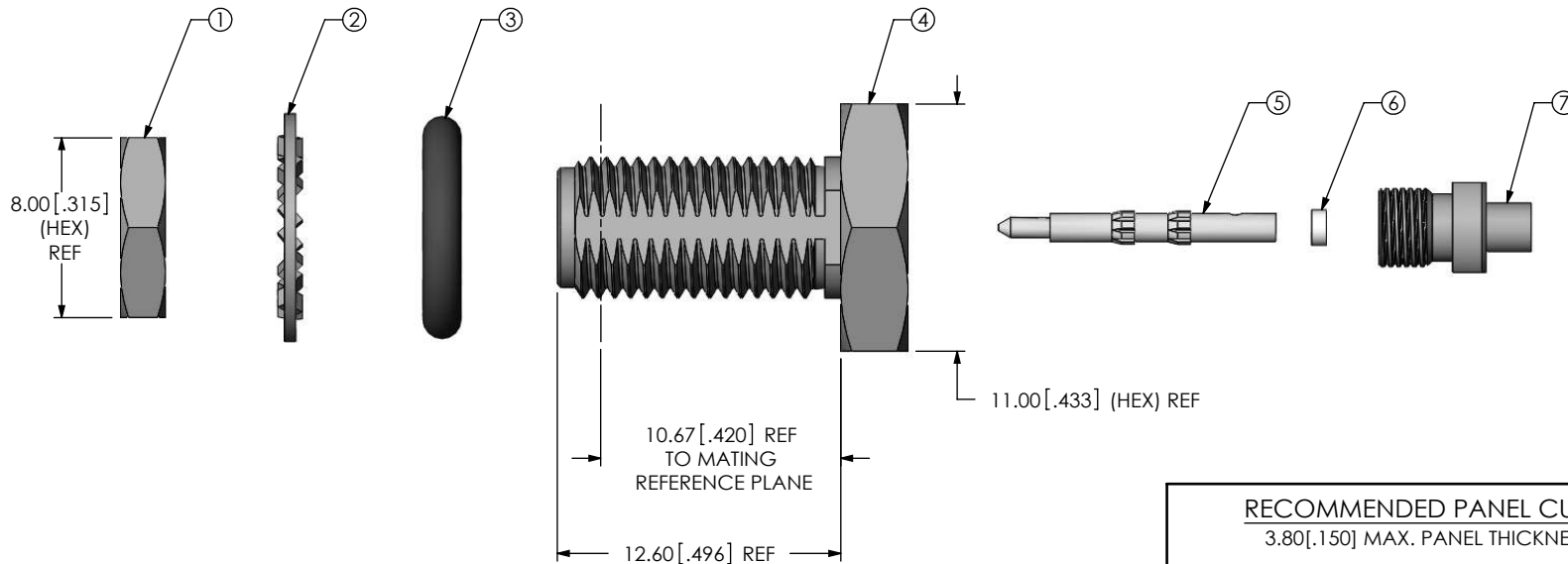

NOTES:

- 1. $\text{\textcircled{C}}$ REPRESENTS A CRITICAL DIMENSION.
- 2. NOTE DELETED.
- 3. NOTE DELETED.
- 4. NOTE DELETED.
- 5. PRODUCT TO BE PACKAGED PER PACKAGING STANDARD CO-HD-WI-3040-M.
- 6. NOTE DELETED.
- 7. NOTE DELETED.
- 8. NOTE DELETED.

UNLESS OTHERWISE SPECIFIED, DIMENSIONS ARE IN MILLIMETERS [INCHES]. TOLERANCES ARE:
 DECIMALS ANGLES
 .X: ± 0.3 [.01] 5°
 .XX: ± 0.13 [.005]
 .XXX: ± 0.051 [.0020]

PROPRIETARY NOTE
 THIS DOCUMENT CONTAINS INFORMATION CONFIDENTIAL AND PROPRIETARY TO SAMTEC, INC. AND SHALL NOT BE REPRODUCED OR TRANSFERRED TO OTHER DOCUMENTS OR DISCLOSED TO OTHERS OR USED FOR ANY PURPOSE OTHER THAN THAT WHICH IT WAS OBTAINED WITHOUT THE EXPRESSED WRITTEN CONSENT OF SAMTEC, INC.



520 PARK EAST BLVD., NEW ALBANY, IN 47150
 PHONE: 812-944-6733 FAX: 812-948-5047
 e-Mail: info@SAMTEC.com code 55322

MATERIAL: DO NOT SCALE DRAWING SHEET SCALE: 3:1
 SHELL, FERRULE, NUT, WASHER: BRASS
 CONTACT: BRASS
 DIELECTRIC: PTFE
 GASKET: SILICON

DESCRIPTION:
 SMA STR JACK S REV POLARITY BULKHEAD, MH081- 50 OHM
 DWG. NO. **SMA-J-C-X-ST-SR3**

REVISION E

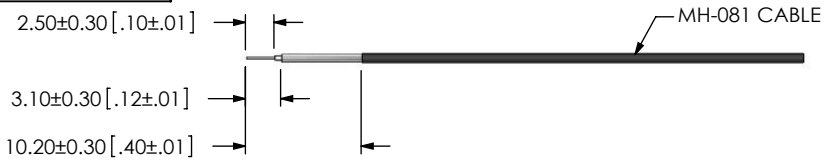

IN PROCESS 1
STRIP AND TIN INNER
CONDUCTOR

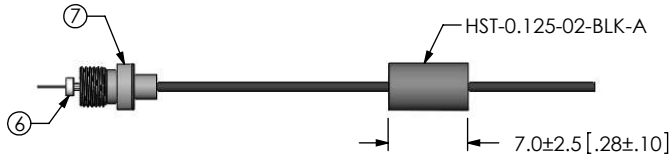

IN PROCESS 2
ADD HEAT SHRINK TUBE,
REAR THREADED BODY,
AND INSULATOR

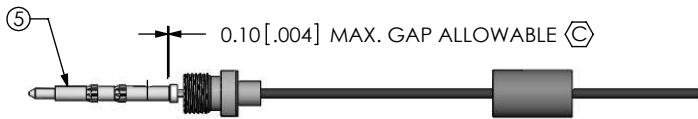

IN PROCESS 3
SOLDER SIGNAL PIN AND
APPLY LOCTITE 680 TO THREADS

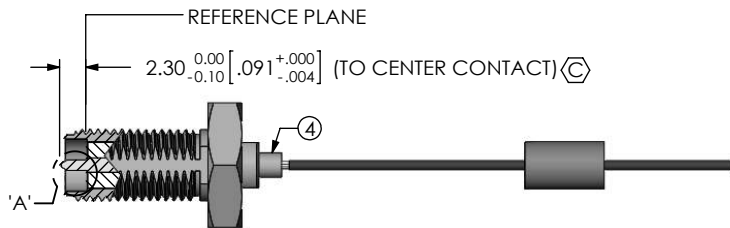

IN PROCESS 4
ADD SUB ASSEMBLY
& TIGHTEN REAR-THREADED
BODY TO 10 IN-LBS

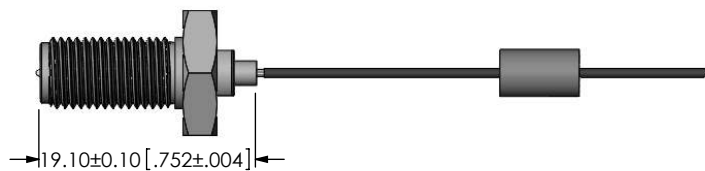

IN PROCESS 5
SOLDER SHIELD

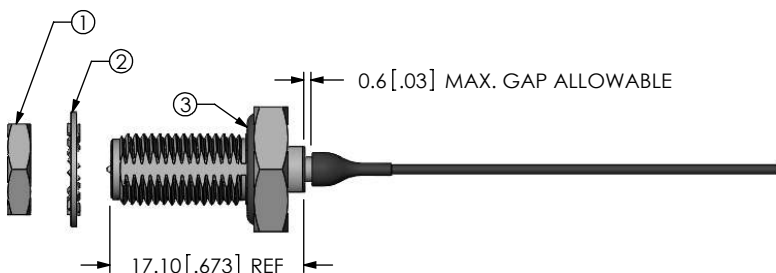

IN PROCESS 6
APPLY HEAT SHRINK TUBING
& ADD GASKET

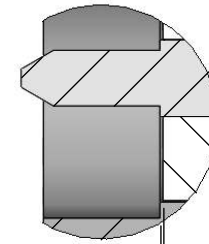

0.05 [.002] REF
(TO INSULATOR)

REFERENCE PLANE

DETAIL 'A'
SCALE 8:1

F:\DWG\MISC\MKTG\SMA-J-C-X-ST-SR3-MKT.SLDDRW

PROPRIETARY NOTE

THIS DOCUMENT CONTAINS INFORMATION
CONFIDENTIAL AND PROPRIETARY TO
SAMTEC, INC. AND SHALL NOT BE REPRODUCED
OR TRANSFERRED TO OTHER DOCUMENTS OR
DISCLOSED TO OTHERS OR USED FOR ANY
PURPOSE OTHER THAN THAT WHICH IT WAS
OBTAINED WITHOUT THE EXPRESSED WRITTEN
CONSENT OF SAMTEC, INC.

DO NOT SCALE DRAWING

SHEET SCALE: 3:2

samtec

520 PARK EAST BLVD, NEW ALBANY, IN 47150
PHONE: 812-944-6733 FAX: 812-948-5047
e-Mail: info@SAMTEC.com code 55322

DESCRIPTION:
SMA STR JACK S REV POLARITY BULKHEAD, MH081- 50 OHM

DWG. NO.
SMA-J-C-X-ST-SR3

BY: R MUSSER 04/21/2009 SHEET 2 OF 2