

SJ017353-E

DWG. NO.

SYM.	DCN NO.	DESCRIPTION	DATE	DRAWN	CHECKED	APP'D	APP'D
2	25662	CHANGED MAGAZINE FORM	89. 9. 8				
3	29097	REMOVE NOTES	87.06.01	H. HAYAKAWA (S. KITADA)	K. IBARAKI		

DETAIL B (SCALE 10/1)
(EXCLUDING MATED PORTION)

EXCLUDING
CRIMPING PORTION

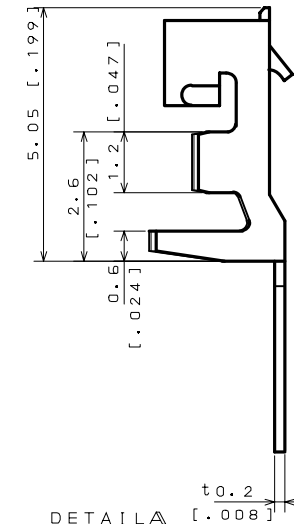
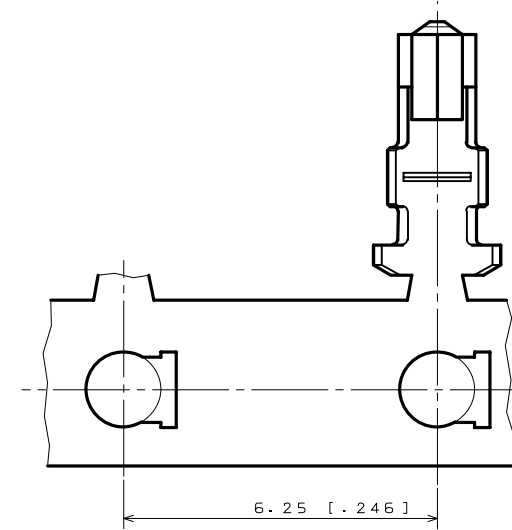
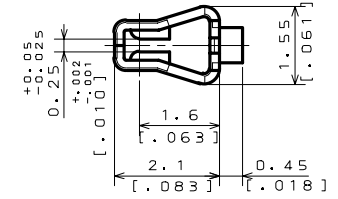
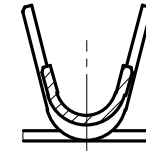
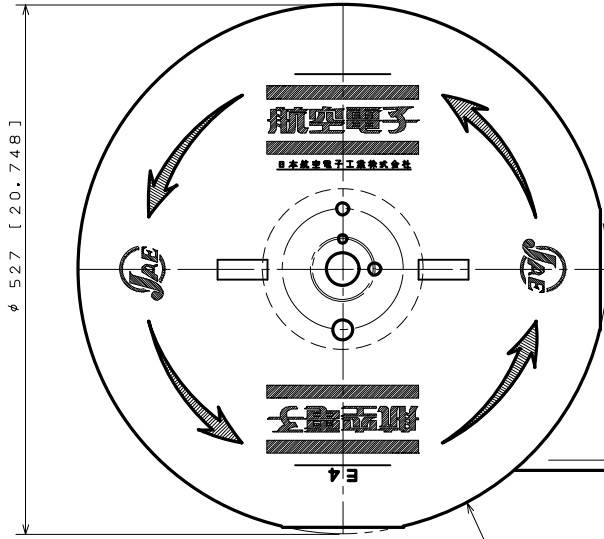

DETAIL A
(SCALE 10/1)

NOTE

1. INSERT PIN ; 0.5 ± 0.05 SQU. [.020] $\pm .002$
2. APPLICABLE WIRE ; #24~28AWG, STRANDED.
3. NO PLATING ON THE SEARING AREAS.
4. APPLICABLE CRIMPING MACHINE FOR THIS MAGAZINE ASS'Y IS CT350-2-1LS.
5. APPLICABLE WIRE INSULATION OUTER DIA: 1.0~1.6mm, [.039] ~ [.063]

DIMENSIONS ARE IN MILLIMETERS
TOLERANCES ON: (INCHES)

DIMENSION	TOLERANCE	ANGLES	CONCENTRICITY
. . .	$\pm .51$ [.020]	\times° \pm	
. X	$\pm .31$ [.012]	\times^{\times} \pm	
. XX	$\pm .11$ [.004]		WITHIN $\pm .1$ [.004]
. XXX			

ITEM	DESCRIPTION	Q'TY	MATERIAL	FINISH	REMARKS
3	SOCKET CONTACT	10000	PHOSPHOR BRONZE	TIN PLATING	
2	TAPE	1	PAPER		
1	MAGAZINE	1	PAPER		

REFERENCE DOCUMENT JACS-1181	DATE 28. NOV. '83	SCALE	WT.	Q'TY	JAPAN AVIATION ELECTRONICS INDUSTRY, LTD.
MATERIAL	DRAWN E. MURANO	TITLE IL-S-C2-S-10000 (MAGAZINE ASSEMBLY)		 MUSASHINO, AKISHIMA-SHI TOKYO, JAPAN DWG. NO. SJ017353-E	
TREATMENT	CHECKED K. IBARAKI	SERIES IL-S			
FINISH	APP'D T. MIYASHITA	DRAWN H. FUJINO			

DCF-116A



SIZE A3