

THIS DRAWING AND THE SUBJECT MATTER SHOWN THEREON ARE CONFIDENTIAL AND THE PROPERTY OF BEL/STEWART/TRP CONNECTOR AND SHALL NOT BE REPRODUCED, COPIED, OR USED IN ANY MANNER WITHOUT THE WRITTEN CONSENT OF TRP CONNECTOR.

PRODUCT MAY BE PROTECTED BY ONE OR MORE OF THE FOLLOWING US PATENTS:
 5736910 5939955 6425781 6428361 6554638 6840817 7123117
 7429195 7717749 7808751 6217391 6149050 7924130

REVISIONS				
#	LT#	DESCRIPTION	DATE	APPV
2		EC-1411035 COMPANY LOGO CHANGE	05JAN2015	DP TY

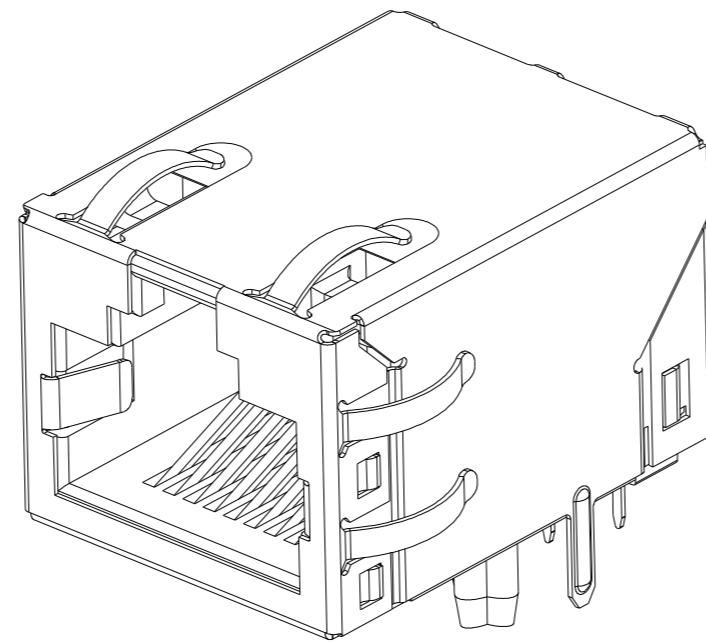
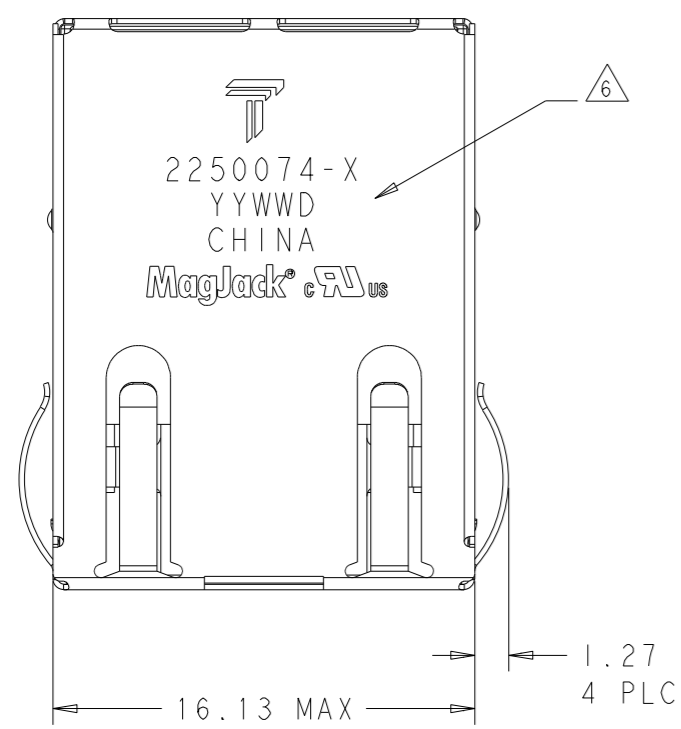

1. MATERIALS

- HOUSING: THERMOPLASTIC, FLAMMABILITY RATING UL 94V-0.
- SHIELD: BRASS 0.20mm THICK, PREPLATED WITH 0.76um MIN SEMI-BRIGHT NICKEL. SOLDER TABS POST DIPPED WITH 2.54um MIN SAC SOLDER.
- CONTACTS: PHOSPHOR BRONZE 0.46mm X 0.30mm, PHOSPHOR BRONZE, 1.27um MIN NICKEL UNDERPLATE, WITH 1.27um MIN GOLD PLATING AT MATING INTERFACE AND 2.54um MIN MATTE TIN ON SOLDER TAILS, OR 1.27um MIN NICKEL UNDERPLATE, WITH 0.05um GOLD PLATING OVER 0.76um MIN PALLADIUM NICKEL PLATING AT MATING INTERFACE AND 2.54um MIN MATTE TIN ON SOLDER TAILS.
- SOLDER TAILS: 0.25mm THICK, PHOSPHOR BRONZE, 1.27um MIN OVERALL NICKEL UNDERPLATE, 3um TIN PLATE

2. RJ45 JACK CAVITY CONFORMS TO FCC RULES AND REGULATIONS PART 68 SUB PART F.

3. MAGNETICS

- APPLICATION: 10 BASE-T
- IMPEDANCE: 100 OHMS
- TURNS RATIO (CHIP:CABLE): TX=1:2.5 RX=1:1
- TRANSMIT OPEN CIRCUIT INDUCTANCE (OCL): 140uH MIN @100kHz, 0.1VRMS
- LEAKAGE INDUCTANCE(LL): 0.30mH MAX @ 100kHz, 0.1VRMS
- INTERWINDING CAPACITANCE(CWW): 15pF MAX @ 100kHz, 0.1VRMS
- ISOLATION VOLTAGE: 2250VDC FOR 60 SECONDS WITH A RISE TIME OF 500 V/SEC

4. OPERATING TEMPERATURE: FROM 0°C TO +70°C.

5. INDICATED MAGNETIC CONNECTIONS ARE SYMMETRICAL TO SUPPORT AUTO-MDI/MDIX.

6. TRP CONNECTOR LOGO, PART NUMBER, DATE CODE, COUNTRY OF ORIGIN AND AGENCY APPROVAL MARKING IN APPROXIMATE LOCATION SHOWN. DATE CODE: YYWW WHERE YY IS YEAR, WW IS WORK WEEK, D IS DAY OF WEEK, WITH SUNDAY=1.

7. PART SHOULD BE RECOMMENDED FOR WAVE SOLDERING PROCESS. PREHEAT TEMPERATURE IS 120°C TO 160°C, 120 SECONDS TO 180 SECONDS, PEAK WAVE SOLDERING TEMPERATURE IS 260°C MAX, 10 SECONDS MAX.

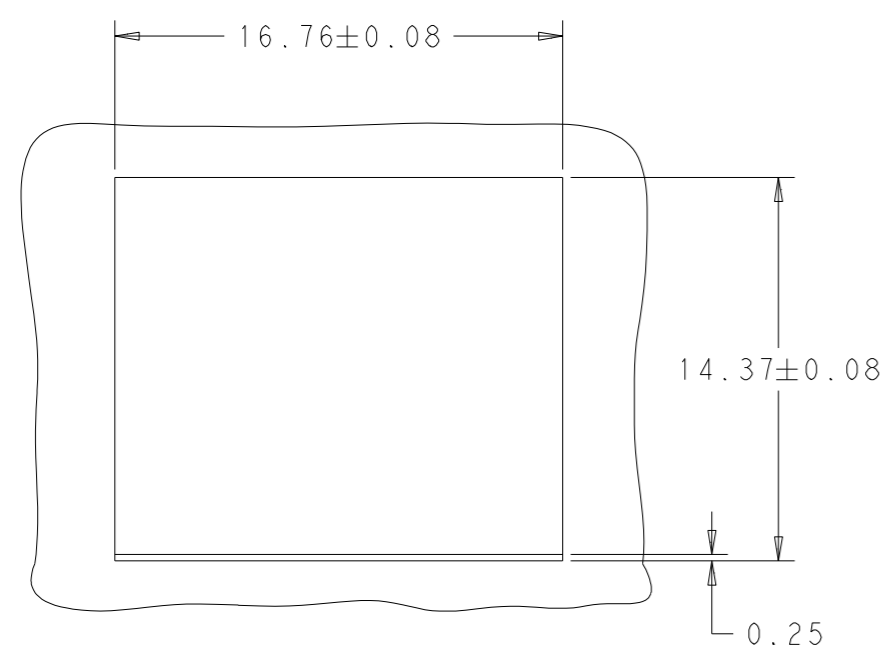
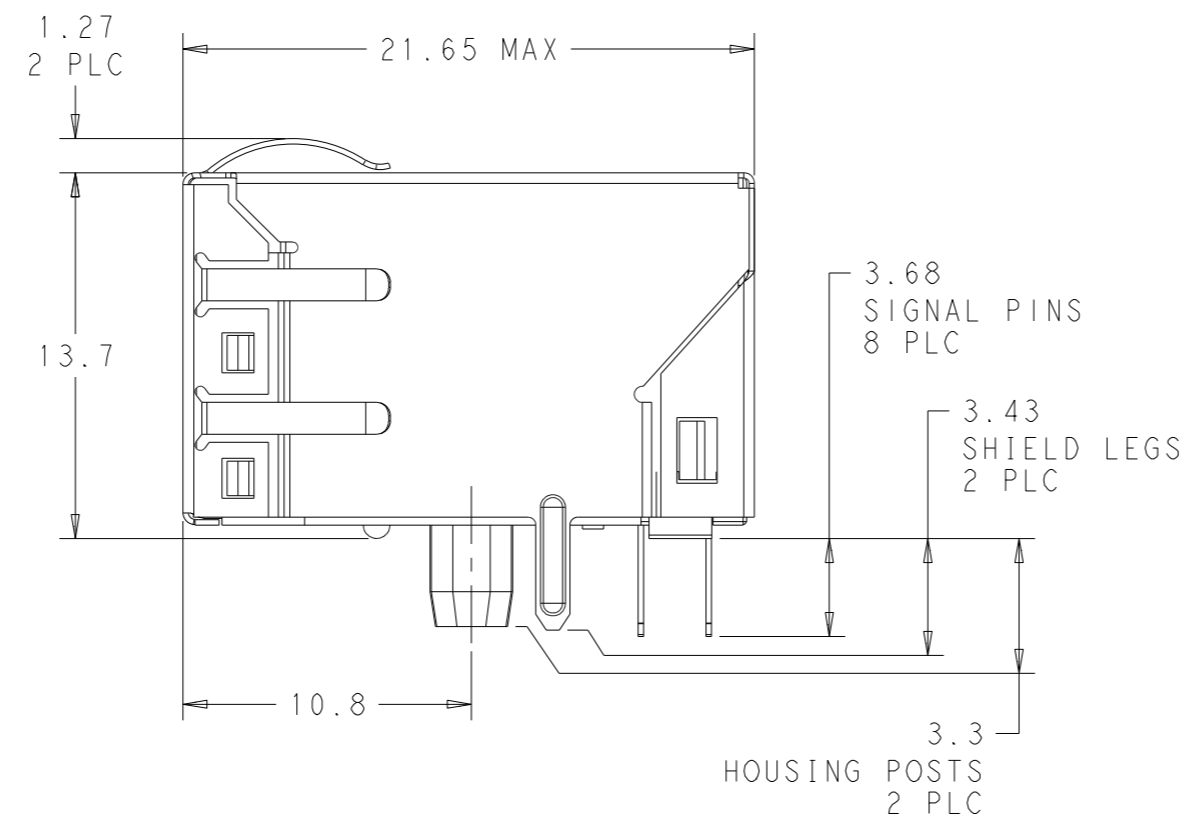
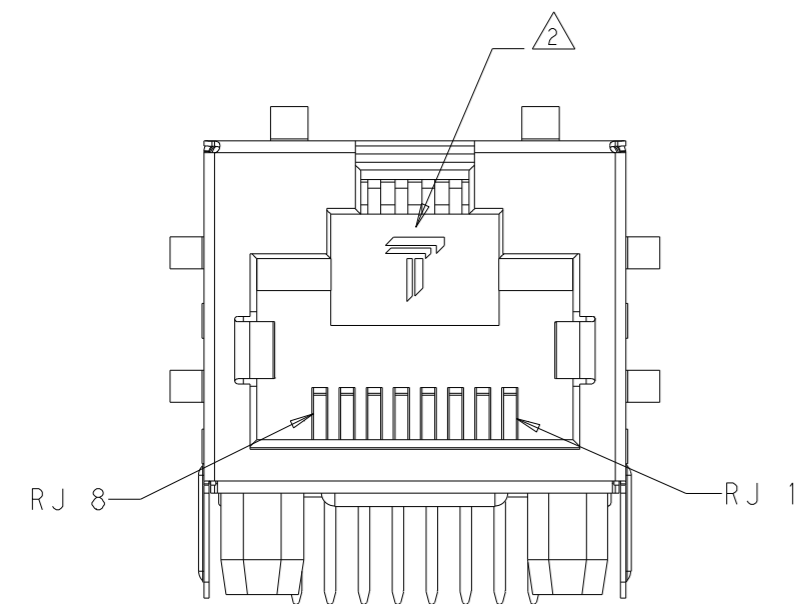

SUGGESTED PANEL CUTOUT

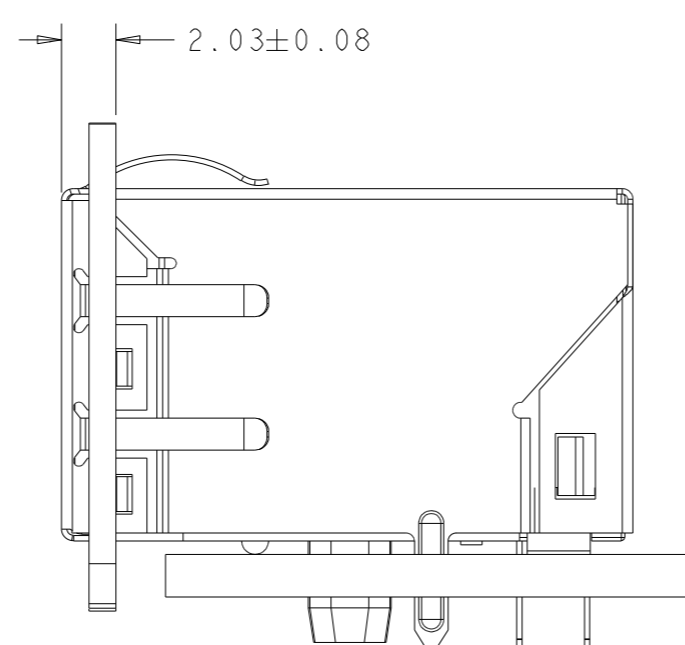



2250074-1

PART NUMBER

THIS DRAWING IS A CONTROLLED DOCUMENT.		OWN ROY LIU 30DEC2013	<p>trp CONNECTOR a bel group</p> <p>DONGGUAN CHINA</p>														
DIMENSIONS: mm		CHK TOWER YU / FRANK LIU 30DEC2013															
TOLERANCES UNLESS OTHERWISE SPECIFIED:		APPV TONY YUAN 30DEC2013															
<table border="1"> <tr> <td>0 PLC</td> <td>±0.25</td> </tr> <tr> <td>1 PLC</td> <td>±0.25</td> </tr> <tr> <td>2 PLC</td> <td>±0.25</td> </tr> <tr> <td>3 PLC</td> <td>±0.25</td> </tr> <tr> <td>4 PLC</td> <td>±0.25</td> </tr> <tr> <td>ANGLES</td> <td>±</td> </tr> <tr> <td>APPLICATION SPEC</td> <td>±</td> </tr> </table>		0 PLC	±0.25	1 PLC	±0.25	2 PLC	±0.25	3 PLC	±0.25	4 PLC	±0.25	ANGLES	±	APPLICATION SPEC	±	MODEL NAME MAGJACK	DESC IXI 724 GIGABIT TAB UP W/O LED
0 PLC	±0.25																
1 PLC	±0.25																
2 PLC	±0.25																
3 PLC	±0.25																
4 PLC	±0.25																
ANGLES	±																
APPLICATION SPEC	±																
PRODUCT SPEC		SINGLE NON-POE	RESTRICTED TO														
CUSTOMER DRAWING		SIZE A1	SCALE 4:1														
		DRAWING NO C=2250074	SHEET 1 OF 3														
			REV 2														

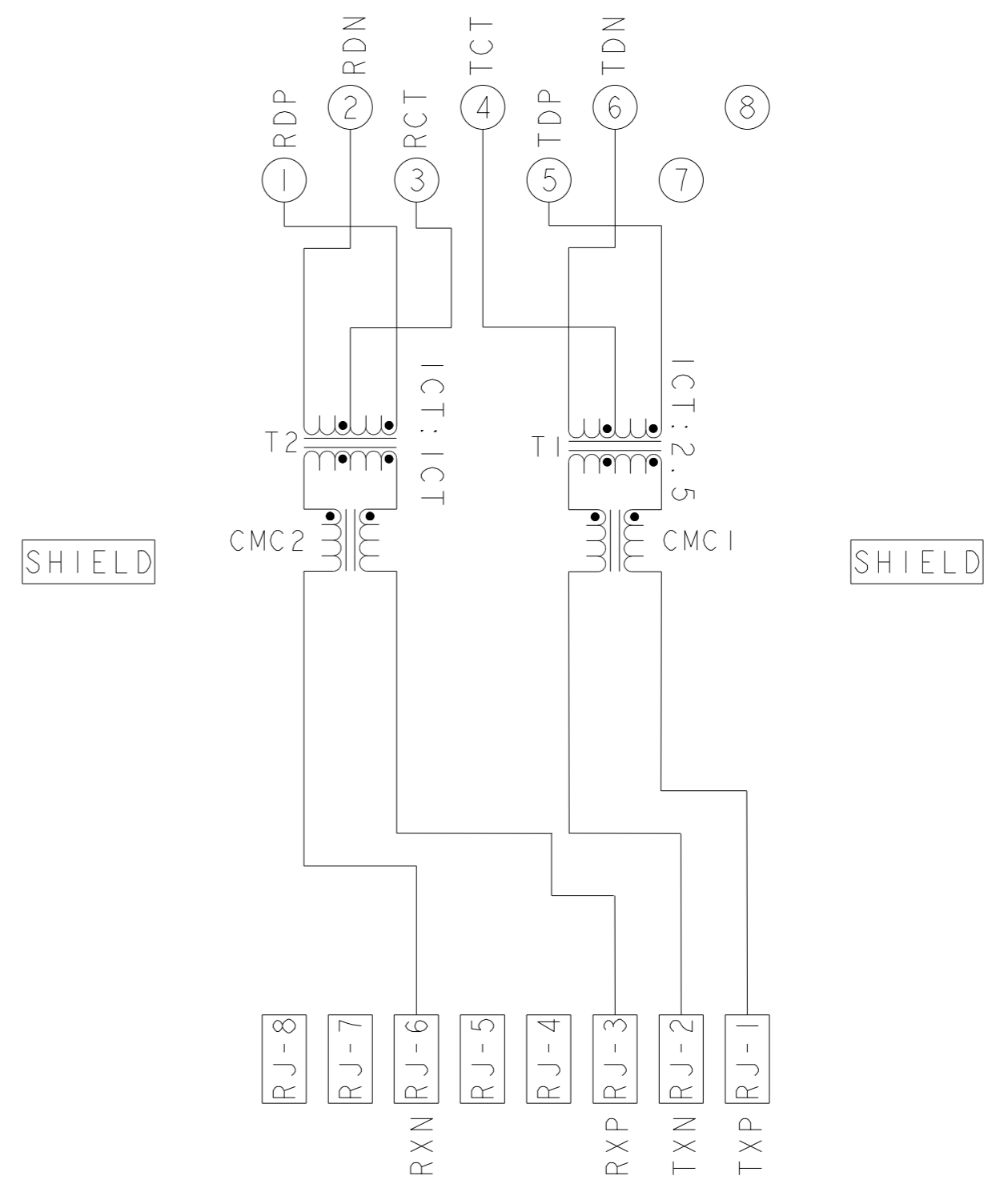
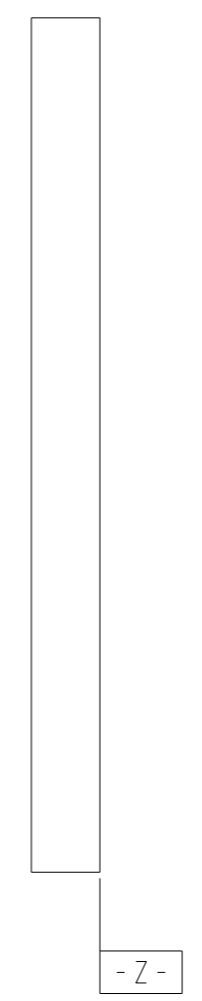
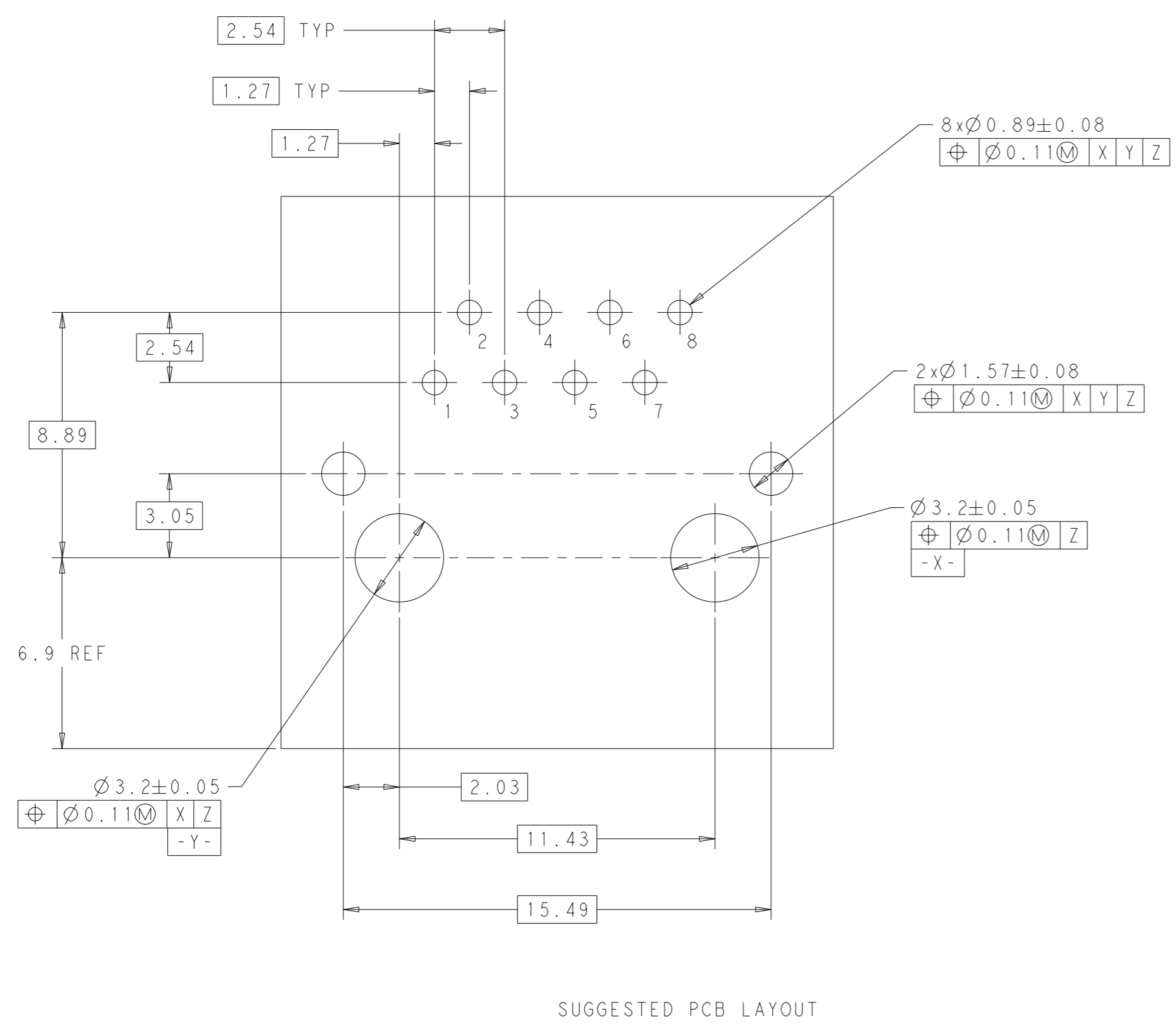
724 10/100 CIRCUIT

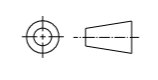

THIS DRAWING IS A CONTROLLED DOCUMENT.		OWN ROY LIU 30DEC2013	 DONGGUAN CHINA
DIMENSIONS: mm		CHK TOWER YU/ FRANK LIU 30DEC2013	
		APPROV TONY YUAN 30DEC2013	
0 PLC ± 0.25 1 PLC ± 0.25 2 PLC ± 0.25 3 PLC ± 0.25 4 PLC \pm ANGLES \pm APPLICATION SPEC \pm		MODEL NAME MAGJACK	DESC 1X1 724 GIGABIT TAB UP W/O LED
PRODUCT SPEC		SINGLE NON-POE	SIZE A1
CUSTOMER DRAWING		SCALE 4:1	SHEET 2 OF 3
		REV 2	

C_2250074					STOCK DISPOSITION			
					A: CONTINUE AS IS B: REWORK C: SCRAP		D: USE OLD FIRST E: PARTS TO CONFORM F: OTHER	
REVISION HISTORY								
DATE	REV	CHANGES	REASON	APPROVAL	INVENTORY (A,B,C,D,E,F)	WORK IN PROCESS (A,B,C,F)	SUPPLIER ORDERS (A,E,F)	OPEN CUST ORDERS (A,E,F)
30DEC2013	1	-	INITIAL RELEASE	TONY YUAN	-	-	-	-
05JAN2015	2	EC-1411035 COMPANY LOGO CHANGE	MARKET REQUEST	TONY YUAN	-	-	-	-

THIS DRAWING IS A CONTROLLED DOCUMENT.

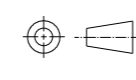
DIMENSIONS:	TOLERANCES UNLESS OTHERWISE SPECIFIED:	DWN ROY LIU 30DEC2013	 trp CONNECTOR <small>a bel group</small>	DONGGUAN CHINA
mm	0 PLC ±0.25 1 PLC ±0.25 2 PLC ±0.25 3 PLC ±0.25 4 PLC ± ANGLES ±	CHK TOWER YU/ FRANK LIU 30DEC2013		DESC IXI 724 GIGABIT TAB UP W/O LED
	APPLICATION SPEC	APPROV TONY YUAN 30DEC2013		MODEL NAME MAGJACK
PRODUCT SPEC			SINGLE NON-POE	SIZE A1
			CUSTOMER DRAWING	SCALE 4:1 SHEET 3 OF 3 REV 2